

HYOSUNG



ST7

GV700C

2010 -

Service manual



SCANDINAVIAN MACHINERY IMPORT ApS

**Holtvej 8-10, Høruphav
6470 Sydals**

Telefon: +45 73 15 11 00

Fax: +45 73 15 11 01

E-mail: info@scanmi.dk

www.scanmi.dk

CVR: 27 73 31 07

FOREWORD

This manual contains an introductory description on HYOSUNG 『ST7』 and procedures for its inspection/service and overhaul of its main components.

Other information considered as generally known is not included.

Read GENERAL INFORMATION section to familiarize yourself with outline of the vehicle and MAINTENANCE and other sections to use as a guide for proper inspection and service.

This manual will help you know the vehicle better so that you can assure your customers of your optimum and quick service.

- ❖ This manual has been prepared on the basis of the latest specification at the time of publication. If modification has been made since then, difference may exist between the content of this manual and the actual vehicle.
- ❖ Illustrations in this manual are used to show the basic principles of operation and work procedures. They may not represent the actual vehicle exactly in detail.

WARNING

This manual is intended for those who have enough knowledge and skills for servicing HYOSUNG vehicles. Without such knowledge and skills, you should not attempt servicing by relying on this manual only.

Instead, please contact your nearby authorized HYOSUNG motorcycle dealer.

GROUP INDEX

GENERAL INFORMATION

1

PERIODIC MAINTENANCE

2

ENGINE

3

EI SYSTEM DIAGNOSIS

4

FUEL SYSTEM AND THROTTLE BODY

5

COOLING SYSTEM

6

ELECTRICAL SYSTEM

7

CHASSIS

8

SERVICING INFORMATION

9



HOW TO USE THIS MANUAL

TO LOCATE WHAT YOU ARE LOOKING FOR :

1. The text of this manual is divided into sections.
2. As the title of these sections is listed on the previous page as GROUP INDEX, select the section where you are looking for.
3. Holding the manual as shown at the right will allow you to find the first page of the section easily.
4. On the first page of each section, its contents are listed. Find the item and page you need.

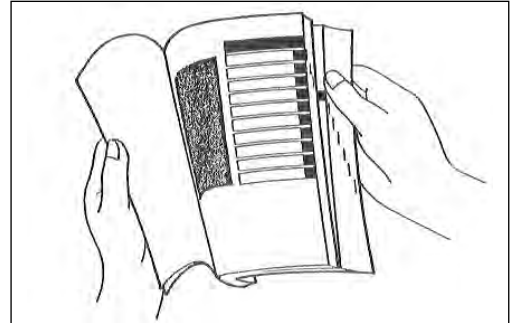





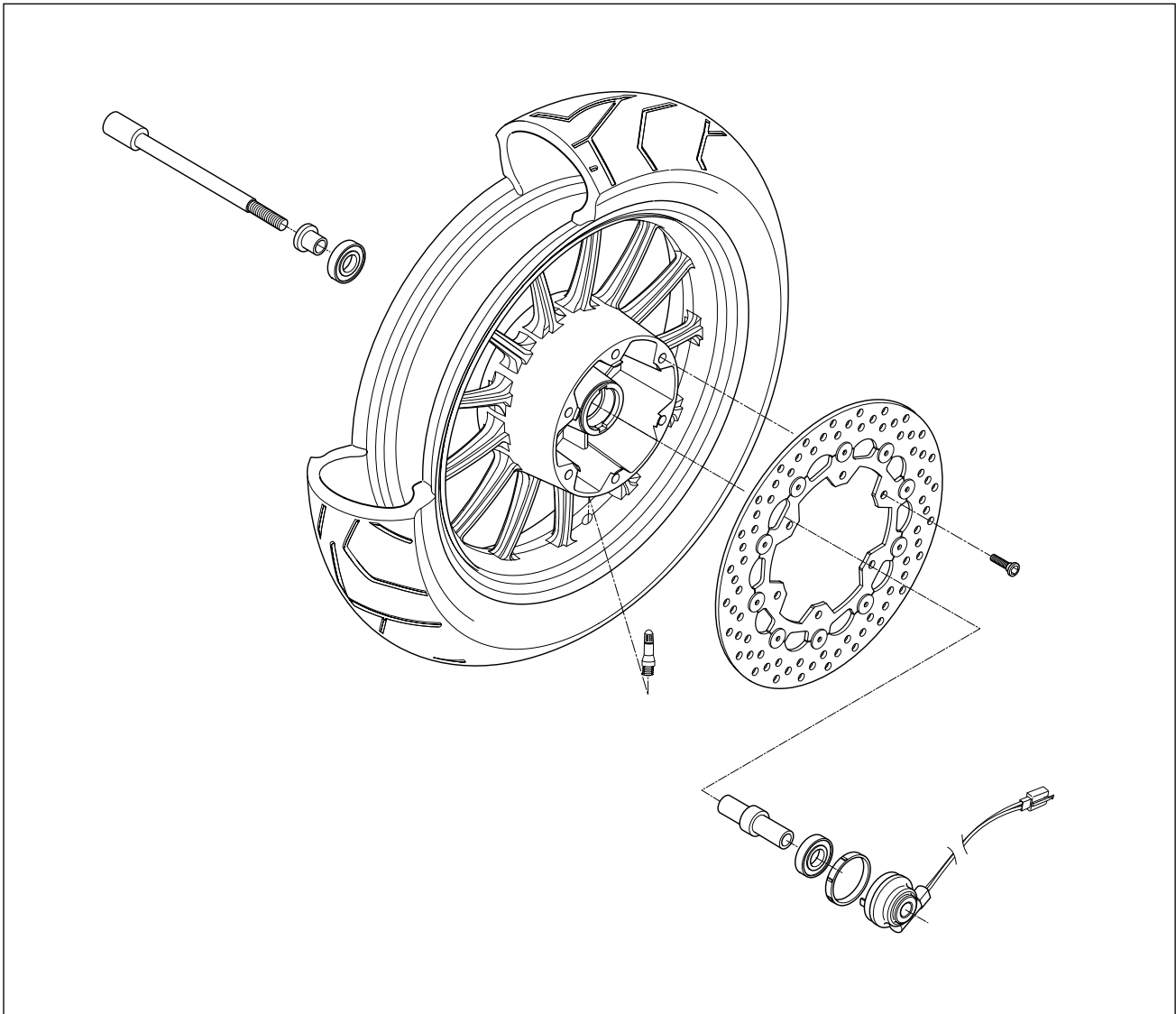











COMPONENT PARTS

Example : Front wheel



SYMBOL

Listed in the table below are the symbols indicating instructions and other information necessary for servicing. The meaning of each symbol is also included in the table.

SYMBOL	DEFINITION	SYMBOL	DEFINITION
	Torque control required. Data beside it indicates specified torque.		Apply THREAD LOCK "1324".
	Apply oil. Use engine oil unless otherwise specified.		Apply or use brake fluid.
	Apply SUPER GREASE "A".		Measure in voltage range.
	Apply SUPER GREASE "C".		Measure in resistance range.
	Apply SILICONE GREASE.		Measure in current range.
	Apply MOLY PASTE.		Measure in diode test range.
	Apply BOND "1215".		Measure in continuity test range.
	Use fork oil.		Use special tool.
	Use engine coolant.		



NOTE

Difference between photographs and actual motorcycles depends on the markets.

ABBREVIATIONS USED IN THIS MANUAL

A

ABDC : After Bottom Dead Center
AC : Alternating Current
API : American Petroleum Institute
ATDC : After Top Dead Center

B

BBDC : Before Bottom Dead Center
BDC : Bottom Dead Center
BTDC : Before Top Dead Center

D

DC : Direct Current
DOHC : Double Over Head Camshaft

E

ECU : Engine Control Unit,
EI Control Unit
EI : Electric fuel Injection,
Electric fuel Injector

F

FP : Fuel Pump

G

GP Switch : Gear Position Switch

I

IAP Sensor : Intake Air Pressure Sensor
(IAPS)
IAT Sensor : Intake Air Temperature Sensor
(IATS)
IG : Ignition
ISC Solenoid : Idle Speed Control Solenoid

L

LCD : Liquid Crystal Display

LED : Light Emitting Diode

LH : Left Hand

M

Max : Maximum

Min : Minimum

O

O₂ Sensor : Oxygen Sensor (O₂S)

P

PV : Purge control Valve

R

RH : Right Hand

RO Switch : Roll Over Switch

S

SAE : Society of Automotive Engineers

SAV Solenoid : Secondary Air Valve Solenoid

T

TDC : Top Dead Center

TP Sensor : Throttle Position Sensor (TPS)

W

WT Sensor : Water Temperature Sensor
(WTS)

WIRE COLOR

B	: Black	Gr	: Gray	Sb	: Light blue
L	: Blue	Lg	: Light green	W	: White
Br	: Brown	O	: Orange	Y	: Yellow
G	: Green	R	: Red		

BL	: Black with Blue tracer	BBr	: Black with Brown tracer
BG	: Black with Green tracer	BO	: Black with Orange tracer
BR	: Black with Red tracer	BW	: Black with White tracer
BY	: Black with Yellow tracer	LB	: Blue with Black tracer
LG	: Blue with Green tracer	LR	: Blue with Red tracer
LW	: Blue with White tracer	LY	: Blue with Yellow tracer
BrB	: Brown with Black tracer	BrW	: Brown with White tracer
GB	: Green with Black tracer	GR	: Green with Red tracer
GY	: Green with Yellow tracer	GrB	: Gray with Black tracer
GrR	: Gray with Red tracer	GrW	: Gray with White tracer
OB	: Orange with Black tracer	OL	: Orange with Blue tracer
OG	: Orange with Green tracer	OR	: Orange with Red tracer
OW	: Orange with White tracer	OY	: Orange with Yellow tracer
RB	: Red with Black tracer	RW	: Red with White tracer
WB	: White with Black tracer	WL	: White with Blue tracer
WR	: White with Red tracer	YB	: Yellow with Black tracer
YL	: Yellow with Blue tracer	YG	: Yellow with Green tracer
YR	: Yellow with Red tracer		

GENERAL INFORMATION

CONTENTS

INFORMATION LABELS	1- 1
GENERAL PRECAUTIONS	1- 1
SERIAL NUMBER LOCATION	1- 3
FUEL, OIL AND ENGINE COOLANT RECOMMENDATIONS	1- 4
BREAK-IN PROCEDURES	1- 6
CYLINDER CLASSIFICATION	1- 6
EXTERIOR ILLUSTRATION	1- 7
SPECIFICATIONS	1- 8

WARNING / CAUTION / NOTE

Please read this manual and follow its instructions carefully.

To emphasize special information, the symbol and the words WARNING, CAUTION and NOTE have special meanings. Pay special attention to the messages highlighted by these signal words.

 WARNING
Indicates a potential hazard that could result in death or injury.

 CAUTION
Indicates a potential hazard that could result in vehicle damage.

NOTE
<i>Indicates special information to make maintenance easier or instructions clearer.</i>

Please note, however, that the warning and cautions contained in this manual cannot possibly cover all potential hazards relating to the servicing, or lack of servicing, of the motorcycle. In addition to the WARNING and CAUTION stated, you must use good judgement and basic mechanical safety principles. If you are unsure about how to perform a particular service operation, ask a more experienced mechanic for advice.

GENERAL PRECAUTIONS

WARNING

- ❖ Proper service and repair procedures are important for the safety of the service machanic and the safety and reliability of the vehicle.
- ❖ When 2 or more persons work together, pay attention to the safety of each other.
- ❖ When it is necessary to run the engine indoors, make sure that exhaust gas is forced outdoors.
- ❖ When working with toxic or flammable materials, make sure that the area you work in is well-ventilated and that you follow all off the material manufacturer's instructions.
- ❖ Never use gasoline as a cleaning solvent.
- ❖ To avoid getting burned, do not touch the engine, engine oil, exhaust system or radiator during or for a while after engine operation.
- ❖ After servicing fuel, oil, engine coolant, exhaust or brake systems, check all lines and fittings related to the system for leaks.

WARNING

- ❖ If parts replacement is necessary, replace the parts with HYOSUNG Genuine Parts or their equivalent.
- ❖ When removing parts that are to be reused, keep them arranged in an orderly manner so that they may be reinstalled in the proper order and orientation.
- ❖ Be sure to use special tools when instructed.
- ❖ Make sure that all parts used in reassembly are clean, and also lubricated when specified.
- ❖ When use of a certain type of lubricant, bond, or sealant is specified, be sure to use the specified type.
- ❖ When removing the battery, disconnect the \ominus battery lead wire first and then the \oplus battery lead wire. When reconnecting the battery, connect the \oplus battery lead wire first and then the \ominus battery lead wire. Finally, cover the \oplus battery terminal with the terminal cover.
- ❖ When performing service to electrical parts, if the service procedures do not require use of battery power, diconnect the \ominus battery lead wire at the battery.
- ❖ Tighten cylinder head and case bolts and nuts, beginning with larger diameter and ending with smaller diameter, from inside to outside diagonally, to the specified tightening torque.
- ❖ Whenever you remove oil seals, gaskets, packing, O-rings, locking washers, cotter pins, circlips, and certain other parts as specified, be sure to replace them with new ones. Also, before installing these new parts, be sure to remove any material left over from the mating surfaces.
- ❖ Never reuse a circlip. When installing a new circlip, take care not to expand the end gap larger than required to slip the circlip over the shaft. After installing a circlip, always ensure that it is completely seated in its groove and securely fitted.
- ❖ Do not use self-locking nuts a few times over.
- ❖ Use a torque wrench to tighten fasteners to the torque values when specified. Wipe off grease or oil if a thread is smeared with them.
- ❖ After reassembly, check parts for tightness and operation.

WARNING

- ❖ To protect environment, do not unlawfully dispose of used engine oil and other fluids: batteries, and tires.
- ❖ To protect Earth's natural resouces, properly dispose of used vehicles and parts.

SERIAL NUMBER LOCATION

The frame serial number or V.I.N. (Vehicle Identification Number) is stamped on the right side of the steering head tube. The engine serial number is stamped on the left downside of the crankcase assembly. These numbers are required especially for registering the machine and ordering spare parts.

● FRAME SERIAL NUMBER

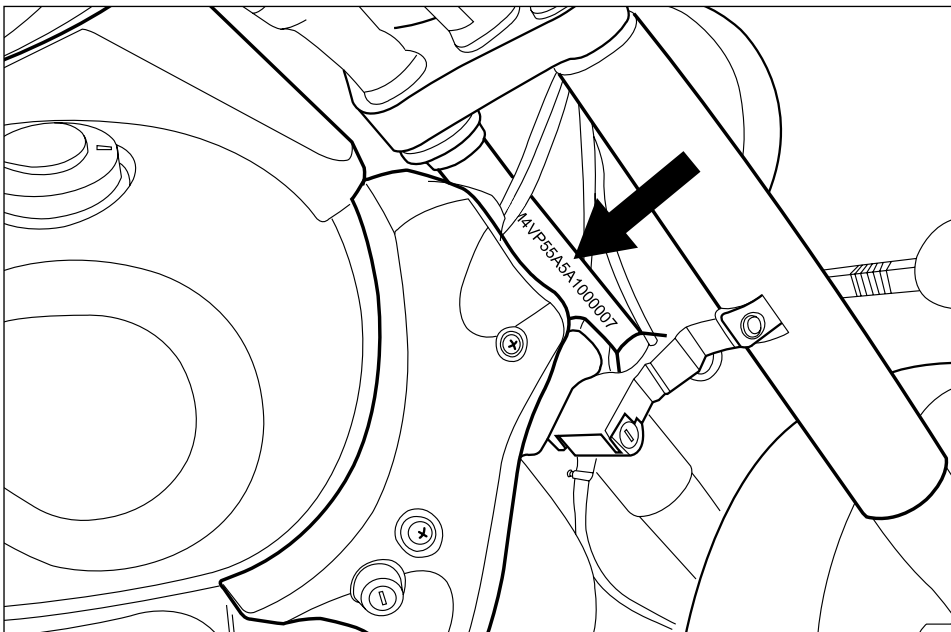

● ENGINE SERIAL NUMBER

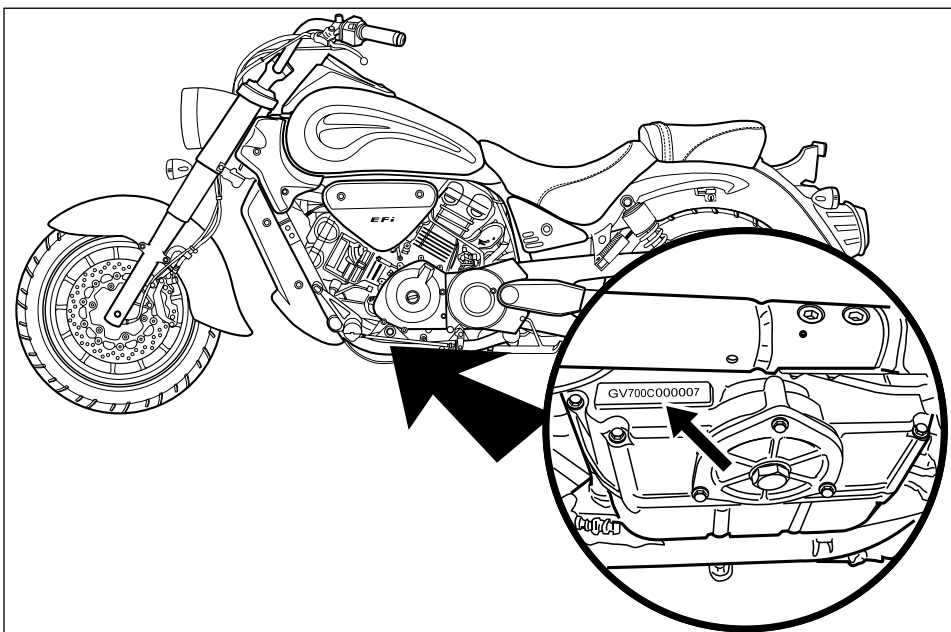

FUEL, OIL AND ENGINE COOLANT RECOMMENDATIONS

⦿ FUEL

Gasoline used should be graded 91 octane (Research Method) or higher. An unleaded gasoline type is recommended.

⦿ ENGINE OIL

▣ ENGINE OIL SPECIFICATION

Classification system	Grade
API	Over SL
SAE	10W/40

※ If an SAE 10W/40 motor oil is not available, select an alternative according to the following chart.

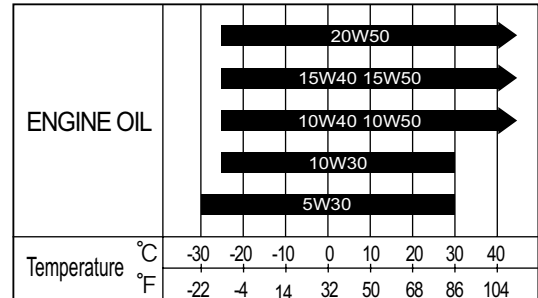

Use a premium quality 4-stroke motor oil to ensure longer service life of your motorcycle.

⚠ WARNING

- ❖ Don't mix the unrecommended oil. It could damage the engine.
- ❖ When refilling the oil tank, don't allow the dust to get inside.
- ❖ Wipe the spilled oil up immediately.
- ❖ Don't put the patch on the cap. It could disturb the oil to be provided and damage the engine.

⦿ BRAKE FLUID

▣ Specification and classification : DOT4

⚠ WARNING

Since the brake system of this motorcycle is filled with a glycol-based brake fluid by the manufacturer, do not use or mix different types of fluid such as silicone-based and petroleum-based fluid for refilling the system, otherwise serious damage will result.

Do not use any brake fluid taken from old or used or unsealed containers.

Never re-use brake fluid left over from a previous servicing, which has been stored for a long period.

⦿ FRONT FORK OIL

▣ Use fork oil : TELLUS #32

1-5 GENERAL INFORMATION

● ENGINE COOLANT

Use an anti-freeze/engine coolant compatible with an aluminum radiator, mixed with distilled water only.

■ WATER FOR MIXING

Use distilled water only. Water other than distilled water can corrode and clog the aluminum radiator.

■ ANTI-FREEZE/ENGINE COOLANT

The engine coolant perform as a corrosion and rust inhibitor as well as anti-freeze. Therefore, the engine coolant should be used at all times even though the atmospheric temperature in your area does not go down to freezing point. Hyosung recommends the use of HYOSUNG COOLANT anti-freeze/engine coolant. If this is not available, use an equivalent which is compatible with an aluminum radiator.

■ LIQUID AMOUNT OF WATER/ENGINE COOLANT

For engine coolant mixture information, refer to cooling system section, page 6-1

CAUTION

Mixture of anti-freeze/engine coolant should be limited to 60%. Mixing beyond it would reduce its efficiency. If the anti-freeze/engine coolant mixing ratio is below 50%, rust inhabiting performance is greatly reduced. Be sure to mix it above 50% even though the atmospheric temperature does not go down to the freezing point.

BREAK-IN PROCEDURES

During manufacture only the best possible materials are used and all machined parts are finished to a very high standard but it is still necessary to allow the moving parts to "BREAK-IN" before subjecting the engine to maximum stresses.

The future performance and reliability of the engine depends on the care and restraint exercised during its early life. The general rules are as follows :

- Keep to these break-in procedures :

Interval	Maximum throttle opening
Initial 800 km (500 miles)	Less than 1/2 throttle
Up to 1,600 km (1,000 miles)	Less than 3/4 throttle

- Upon reaching an odometer reading of 1,600 km (1,000 miles) you can subject the motorcycle to full throttle operation.
- Do not maintain constant engine speed for an extended period during any portion of the break-in. Try to vary the throttle position.

CYLINDER CLASSIFICATION

The engine of 『ST7』 is composed of the two cylinder, is classified into the front cylinder and rear cylinder as basis of the motorcycle ahead.

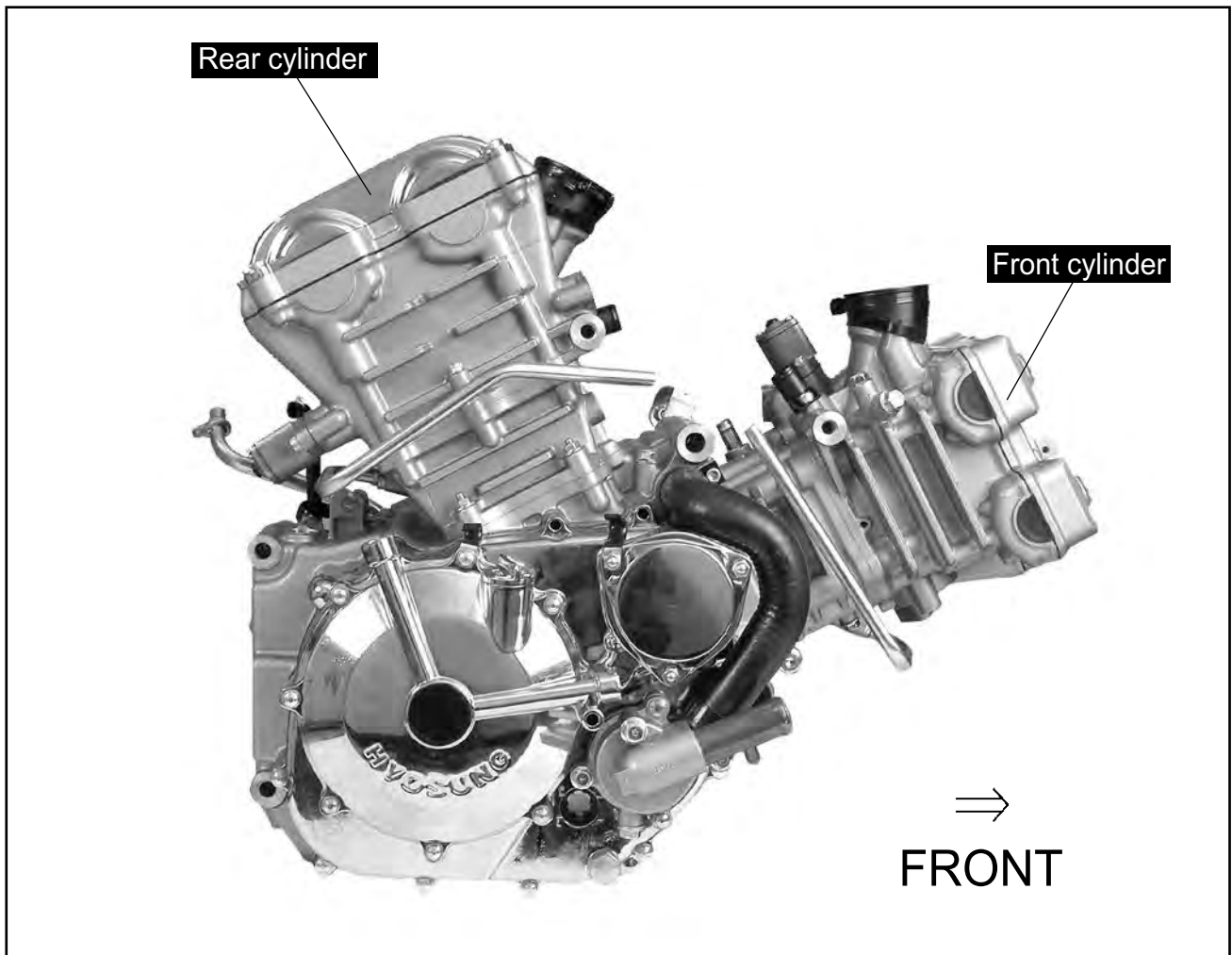

EXTERIOR ILLUSTRATION

Unit : mm

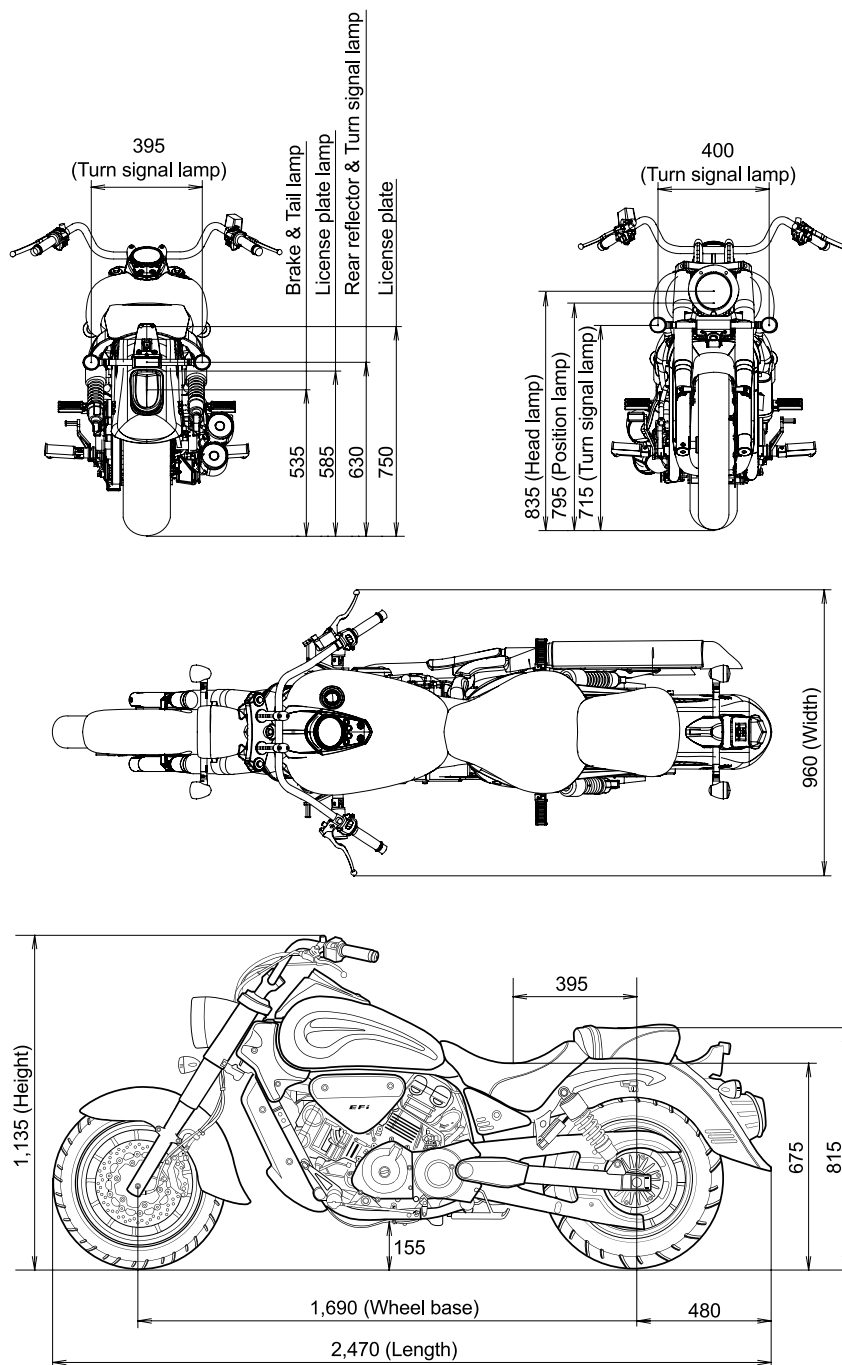

SPECIFICATIONS

⊙ DIMENSIONS AND DRY MASS

ITEM	<i>ST7</i>
Overall length	2,470 mm (97.2 in)
Overall width	960 mm (37.8 in)
Overall height	1,135 mm (44.7 in)
Wheelbase	1,690 mm (66.5 in)
Ground clearance	155 mm (6.1 in)
Mass of vehicle in running order	244 kg (538 lbs)

⊙ ENGINE

ITEM	<i>ST7</i>
Type	Four-stroke, DOHC, Liquid-cooled
Number of cylinder	V-2 cylinder
Bore	81.5 mm (3.21 in)
Stroke	65.0 mm (2.56 in)
Piston displacement	678.2 cm ³ (41.4 in ³)
Fuel system	Electric fuel injection
Starter system	Electric starter
Lubrication system	Wet sump

⊙ TRANSMISSION

ITEM	<i>ST7</i>	
Clutch	Wet multi-plate type	
Transmission	5-speed constant mesh	
Gearshift pattern	1-down, 4-up	
Final reduction	2.69	
Gear ratio	1st	2.46
	2nd	1.78
	3rd	1.38
	4th	1.13
	5th	0.96
Drive belt	Poly chain belt	

⊙ CHASSIS

ITEM	ST7
Front suspension	Telescopic type
Rear suspension	Swingarm type
Steering angle	38 ° (right & left)
Caster	33 °
Trail	142 mm (5.6 in)
Front brake	Disk brake
Rear brake	Disk brake
Front tire size	120/80 - 16 60H
Rear tire size	170/80 - 15 77H
Front fork stroke	130 mm (5.12 in)

⊙ ELECTRICAL

ITEM	ST7
Ignition type	ECU
Ignition timing	BTDC 5 ° / 1,600 rpm and BTDC 35 ° / 7,000 rpm
Spark plug	CR8E
Battery	12V 12Ah (MF)
Fuse	Main : 30 A
	ECU : 15 A
Head lamp	12 V - H4 : 60/55 W × 1
Position lamp	12 V - W5 W × 1
Turn signal lamp	12 V - RY10 W × 4
Brake / Tail lamp	LED type
License plate lamp	12 V - W5 W × 1

※ LED : Light Emitting Diode

⊙ CAPACITIES

ITEM	ST7	
Fuel tank	17.0 ℓ	
Engine oil capacity	Oil change	3,000 ml
	Oil and filter change	3,200 ml
	Engine overhaul	3,400 ml
Front fork oil capacity (One side)	370 ± 4 cc	

NOTE

The specifications are subject to change without notice.

PERIODIC MAINTENANCE

CONTENTS

PERIODIC MAINTENANCE SCHEDULE	2- 1
PERIODIC MAINTENANCE CHART	2- 1
LUBRICATION POINTS	2- 2
MAINTENANCE PROCEDURES	2- 3
VALVE CLEARANCE	2- 3
SPARK PLUG	2- 5
EXHAUST PIPE BOLTS AND MUFFLER MOUNTING BOLTS	2- 7
AIR CLEANER	2- 7
ENGINE IDLE SPEED	2- 9
THROTTLE CABLE PLAY	2- 9
FUEL HOSE	2-10
CLUTCH	2-10
ENGINE OIL	2-12
ENGINE OIL FILTER	2-14
DRIVE BELT	2-15
BRAKE SYSTEM	2-17
STEERING	2-22
FRONT FORK	2-22
REAR SUSPENSION	2-22
TIRE	2-23
CHASSIS BOLTS AND NUTS	2-23
ENGINE COOLANT	2-24
RADIATOR HOSE	2-26
COMPRESSION PRESSURE	2-27
OIL PRESSURE	2-28

2-1 PERIODIC MAINTENANCE

PERIODIC MAINTENANCE SCHEDULE

The chart below lists the recommended intervals for all the required periodic service work necessary to keep the motorcycle operating at peak performance and economy.

CAUTION

More frequent servicing should be performed on motorcycles that are used under severe conditions.

PERIODIC MAINTENANCE CHART

■ ENGINE

Item	Interval	Initial 1,000 km	Every 6,000 km	Every 12,000 km	page
Air cleaner element		Clean every 3,000 km . Replace every 12,000 km			2-7
Exhaust pipe bolts and muffler mounting bolts		Tighten	Tighten	—	2-7
Valve clearance adjust		Inspect	Inspect	—	2-3
Cylinder head bolt		Tighten	Tighten	—	3-52
Cylinder head & Cylinder		—	—	Remove carbon	3-23
Spark plug		Clean	Clean	Replace	2-5
Fuel hose		Inspect	Inspect	—	2-10
		Replace every 4 years			
Engine oil filter		Replace	Replace	—	2-14
Engine oil		Replace	Replace	—	2-12
Throttle cable		Inspect	Inspect	—	2-9
Idle speed		Inspect	Inspect	—	2-9
Clutch		Inspect	Inspect	—	2-10
Engine coolant		Replace every 2 years			2-24
Radiator hoses		—	Inspect	—	2-26
		Replace every 4 years			

■ CHASSIS

Item	Interval	Initial 1,000 km	Every 6,000 km	Every 12,000 km	page
Drive belt		Inspect every 1,000km			2-15
Brake		Inspect	Inspect	—	2-17
Brake hoses		Inspect	Inspect	—	2-17
		Replace every 4 years			
Brake fluid		Inspect	Inspect	—	2-17
		Replace every 2 years			
Tires		Inspect	Inspect	—	2-23
Steering		Inspect	Inspect	—	2-22
Front forks		—	Inspect	—	2-22
Rear suspension		—	Inspect	—	2-22
Chassis bolts and nuts		Tighten	Tighten	—	2-23

CAUTION

Using poor quality replacement parts can cause your motorcycle to wear more quickly and shorten its useful life. Use only genuine Hyoung replacement parts or their equivalent.

LUBRICATION POINTS

Proper lubrication is important for smooth operation and long life of each working part of the motorcycle. Major lubrication points are indicated below.

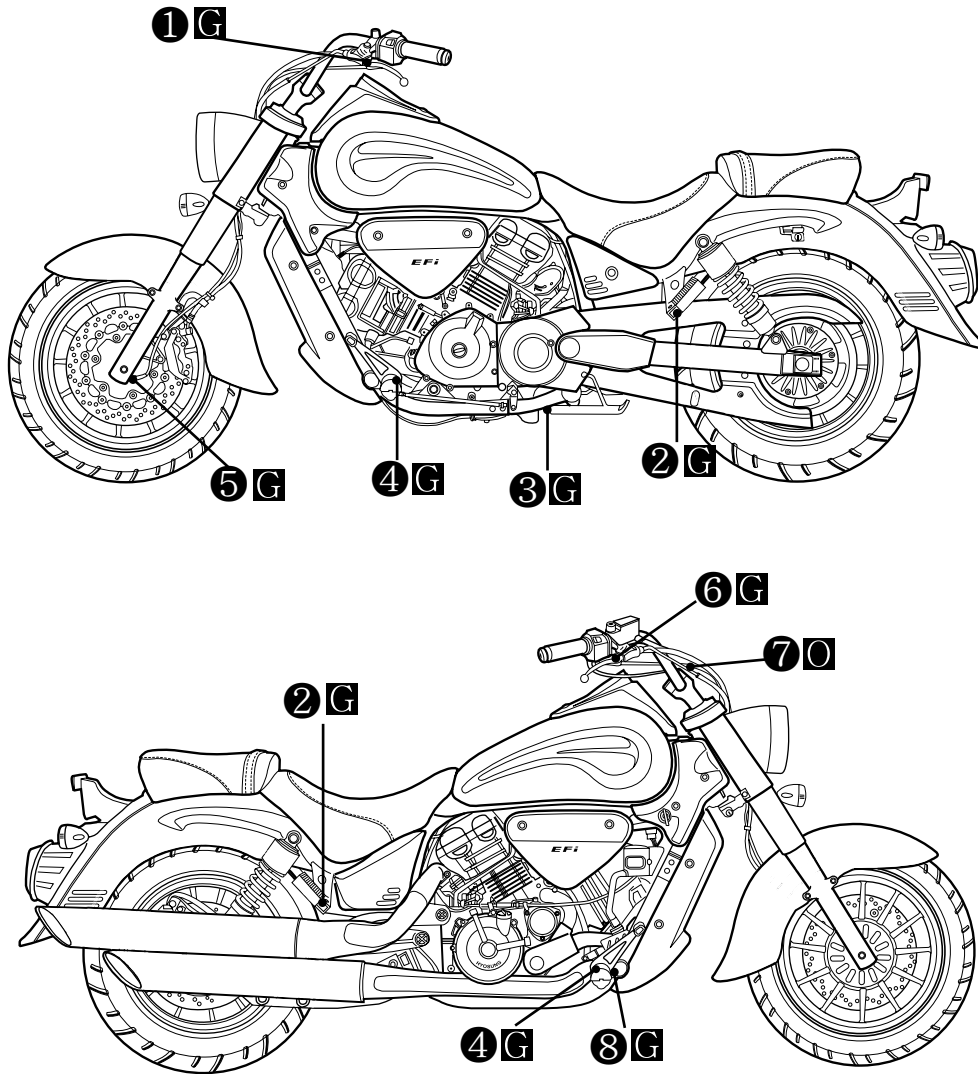

- ① Clutch lever holder and clutch cable
- ② Passenger footrests pivot
- ③ Side stand pivot and spring hook
- ④ Footrests pivot

- ⑤ Speedo sensor
- ⑥ Front brake lever holder
- ⑦ Throttle cable
- ⑧ Rear brake pedal pivot

⓪ - Motor oil, Ⓜ - Grease

NOTE

- ❖ Before lubricating each part, clean off any rusty spots and wipe off any grease, oil, dirt or grime.
- ❖ Lubricate exposed parts which are subject to rust, with either engine oil or grease whenever the motorcycle has been operated under wet or rainy condition.

MAINTENANCE PROCEDURES

This section describes the service procedures for each item mentioned in the Periodic Maintenance chart.

VALVE CLEARANCE

Inspect Interval

Inspect Initial 1,000 km and Every 6,000 km thereafter.

CAUTION

The clearance specification is for COLD state.

Excessive valve clearance results in valve noise and insufficient valve clearance results in valve damage and reduce power.

Check the intake and exhaust valve clearances at the distances indicated above and adjust the valve clearances to specification, if necessary.

The valve clearance specification is different for intake and exhaust valves.

Valve clearance adjustment must be checked and adjusted :

- 1) at the time of periodic inspection,
 - 2) when the valve mechanism is serviced, and
 - 3) when the camshafts are removed.
- Remove the radiator cover and radiator.
(Refer to page 2-5)
 - Remove the right air cleaner box.
 - Remove the seat and fuel tank. (Refer to page 5-2)
 - Remove the spark plugs. (Refer to page 2-5)
 - Remove the cylinder head cover ① and ②.
 - Remove the magneto cover plug ③ and the valve timing inspection plug ④.
 - Rotate the magneto rotor counter-clockwise to set the front cylinder's piston at TDC (Top Dead Center) of the compression stroke.
(Rotate the rotor until "F" line on the rotor is aligned with the center of hole on the crankcase.)
 - To inspect the front cylinder's valve clearance, insert the thickness gauge to the clearance between the camshaft and the tappet.



FRONT CYLINDER

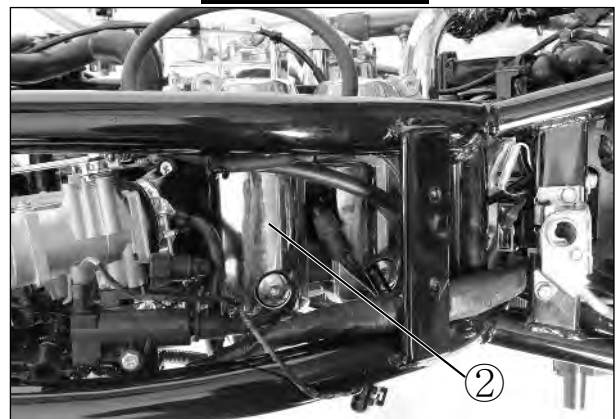

REAR CYLINDER

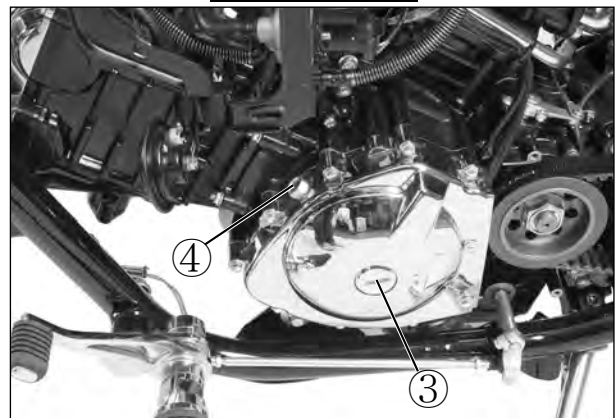

Valve clearance	Standard (When cold)
IN.	0.1 ~ 0.2 mm (0.004 ~ 0.008 in)
EX.	0.28 ~ 0.32 mm (0.011 ~ 0.013 in)

 Thickness gauge : 09900-20806

- If the clearance is out of specification, first remove the cam chain tensioner, camshaft housing, camshaft. To install the tappet shim at original position, record the shim NO. and clearance to present by "A", "B", "C", "D" mark on the cylinder head.

Select the tappet that agree with tappet clearance (vertical line) and shim NO.(horizontal line) as refer to the tappet shim selection chart. (Refer to page 9-39 · 40)

Adjust valve timing, install the camshaft housing and the tension adjuster.

After the crankshaft rotate about 10 times, measure the valve clearance.

If the clearance be not correct, adjust the standard clearance as the same manner above.

- In case of valve adjustment which is not the tappet shim selection chart, please follow instructions of example in the below.

For example, the intake clearance is 0.4 and the shim is 170 (1.70 mm), select 195 (1.95 mm) of the shim which 170 (1.70 mm) of the shim add up the excess clearance 0.25 mm when adjust with the standard 0.15 as the intake standard clearance 0.1 ~0.2 mm.

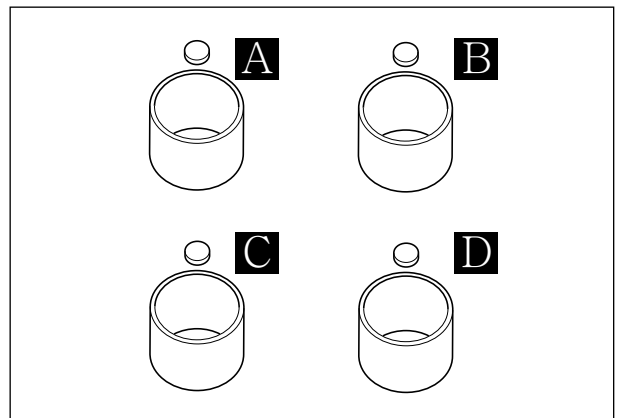
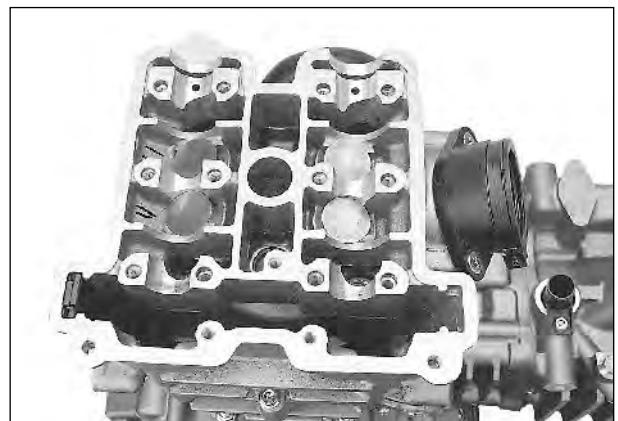
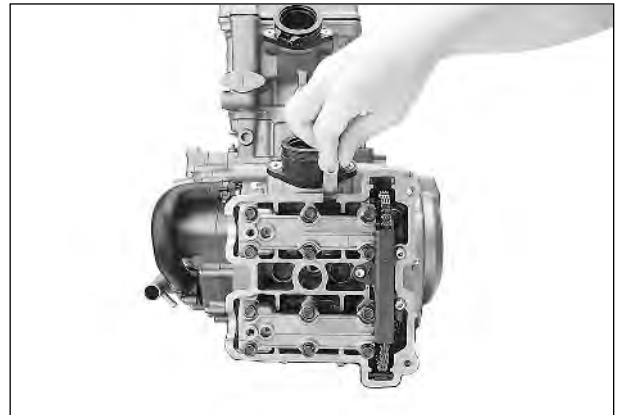

CAUTION

- ❖ Valve clearance should be checked when the engine is cold.
- ❖ If you don't rotate the crankshaft about 10 times before measuring the valve clearance, there is no meaning of valve clearance.

- Rotate the magneto rotor to set the rear cylinder's piston at TDC(Top Dead Center) of the compression stroke. (Rotate the rotor 285° counter-clockwise from the " | F" line, and until the " | R" line on the rotor is aligned with the center of hole on the crankcase.)

- Inspect the rear cylinder's valve clearance with the same manner of the front cylinder.



SPARK PLUG

Inspect Interval

*Clean Initial 1,000 km and Every 6,000 km thereafter.
Replace Every 12,000 km.*

- Remove the four radiator cover mounting bolts.

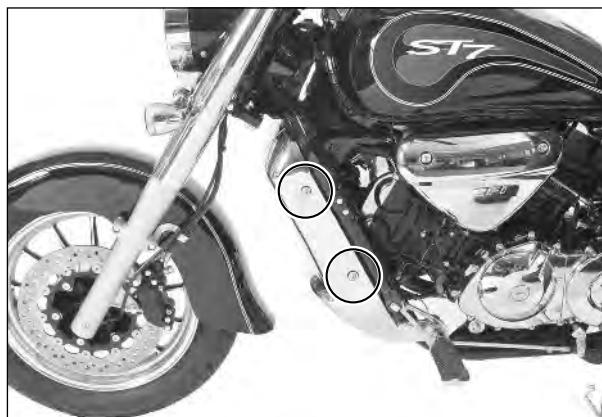

- Remove the four radiator mounting bolts.

WARNING

The hot radiator and the hot engine can burn you. Wait until the radiator and the engine are cool enough to touch.

CAUTION

- ❖ Be careful not to damage the radiator fins.
- ❖ Do not extract the radiator hose.

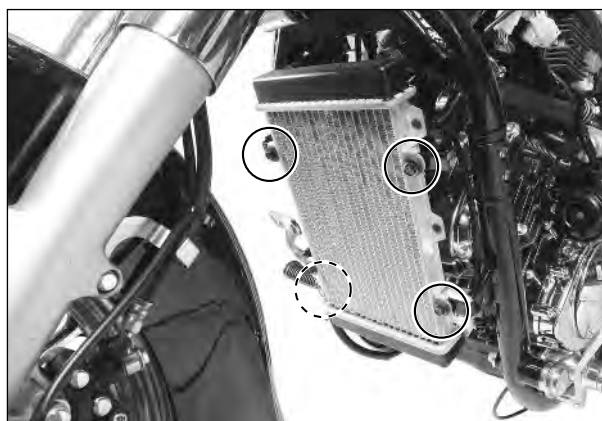

- Remove the front seat and fuel tank.
(Refer to page 5-2)

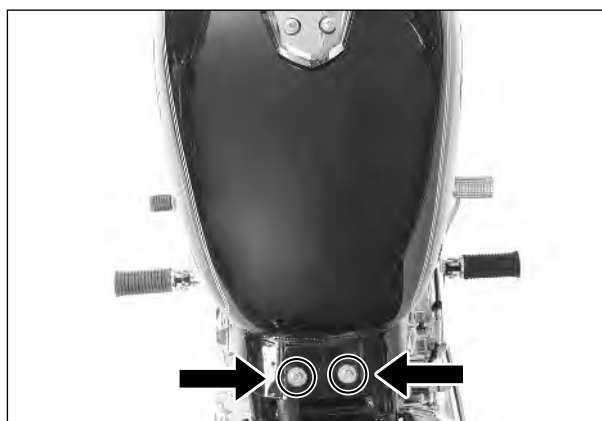

- Disconnect the spark plug caps.
- Remove the spark plugs.

TYPE	SPARK PLUG SPECIFICATION
Hot type	CR7E
Standard type	CR8E
Cold type	CR9E



■ CARBON DEPOSITS

Check to see if there are carbon deposits on the spark plug.

If carbon is deposited, remove it using a wire or pin with a pointed end.

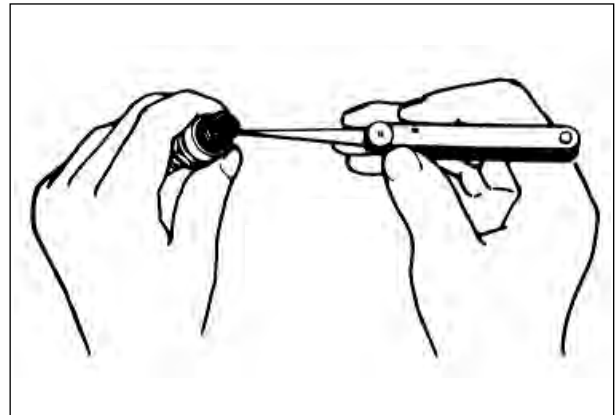

■ SPARK PLUG GAP

Measure the spark plug gap using a thickness gauge.

If the spark plug gap is out of specification, adjust the gap.

Spark plug gap 0.7 ~ 0.8 mm (0.028 ~ 0.032 in)

 **Thickness gauge : 09900-20806**

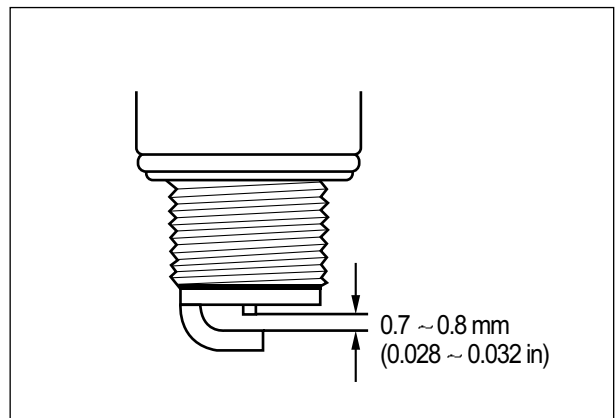

■ ELECTRODE

Check to see the worn or burnt condition of the electrodes.

If it is extremely worn or burnt, replace the spark plug with a new one.

And also replace the spark plug if it has a broken insulator, damaged thread, etc.

CAUTION

To avoid damaging the cylinder head threads ; first, finger tighten the spark plug, and then tighten it to the specified torque using the spark plug wrench.

- Insert the spark plug and finger tighten it to the cylinder head and then tighten it to the specified torque.

 **Spark plug : 11 N · m (1.1 kgf · m)**

EXHAUST PIPE BOLTS AND MUFFLER MOUNTING BOLTS

Inspect Interval

Tighten Initial 1,000 km and Every 6,000 km thereafter.

- Tighten the exhaust pipe bolts ①, and muffler mounting bolts ② to the specified torque.



Exhaust pipe bolt

: 18 ~ 28 N · m (1.8 ~ 2.8 kgf · m)

Muffler mounting bolt

: 20 ~ 25 N · m (2.0 ~ 2.5 kgf · m)

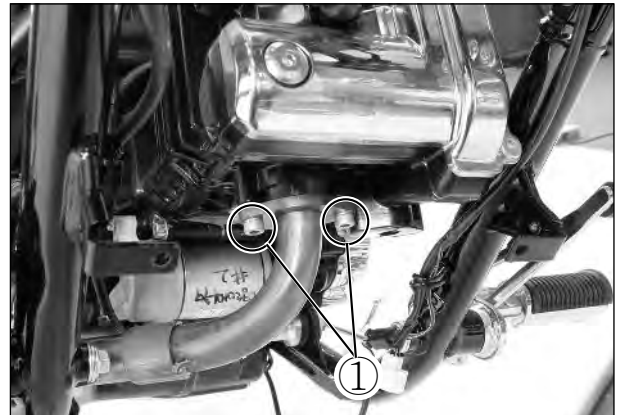

Front Cylinder

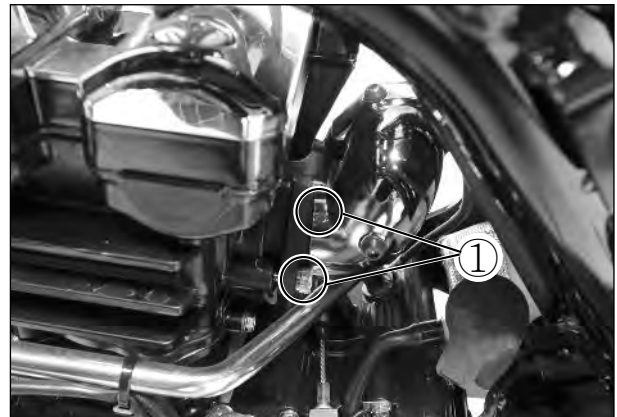
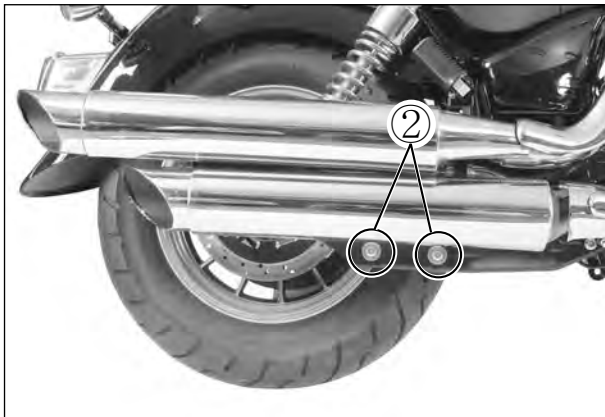

Rear Cylinder

AIR CLEANER

Inspect Interval

Clean Every 3,000 km,
Replace Every 12,000 km.

If the air cleaner is clogged with dust, intake resistance will be increased, with a resultant decrease in power output and an increase in fuel consumption.

Check and clean the air cleaner element in the following manner :

- Remove the air cleaner cover ④ by loosening the two air cleaner cover screws ③.
- Loosen the four air cleaner element screws ⑤.
- Remove the air cleaner element A.

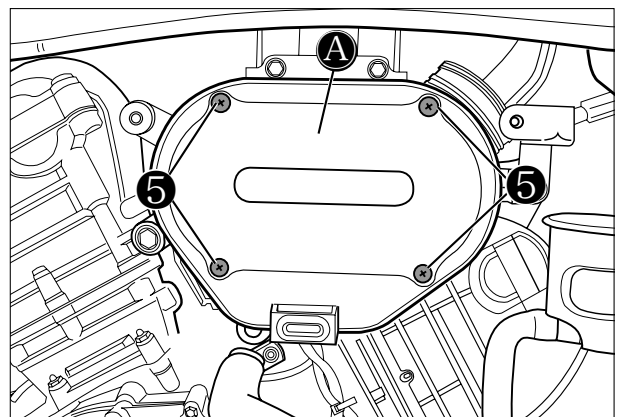
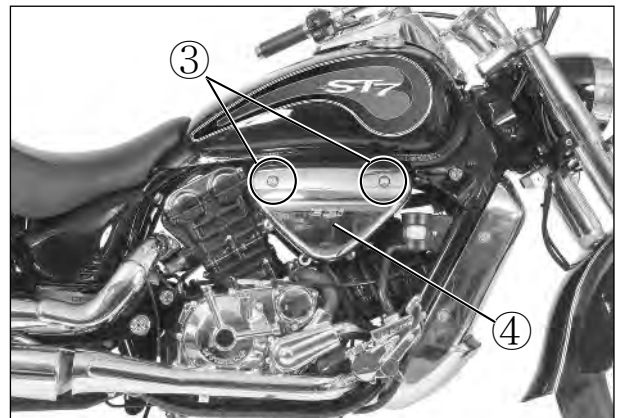

Clean the air cleaner element for the following :

- When the air cleaner element clean with the air gun, necessarily blow at the inside by compressed air.
- Carefully examine the air cleaner element for tears during cleaning. Replace it with a new one if it is torn.
- Assemble the element completely or damage severely the engine.
- Be careful not to allow water to go inside the air cleaner element.

⚠ CAUTION

- ❖ Inspect the air cleaner element for tears. A torn element must be replaced.
- ❖ If driving under dusty conditions, clean the air cleaner element more frequently. The surest way to accelerate engine wear is to operate the engine without the element or with torn element. Make sure that the air cleaner element is in good condition at all times. Life of the engine depends largely on this component!

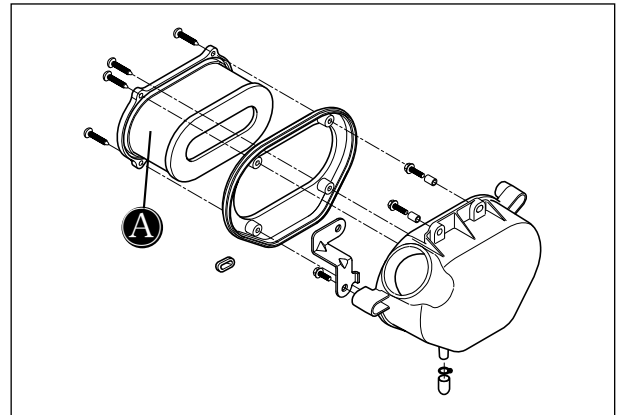

■ AIR CLEANER OIL DRAIN PLUG

Inspect the plug ① and drain water and oil at the periodic maintenance interval.

The air cleaner oil drain plug ① is located beneath the air cleaner case.

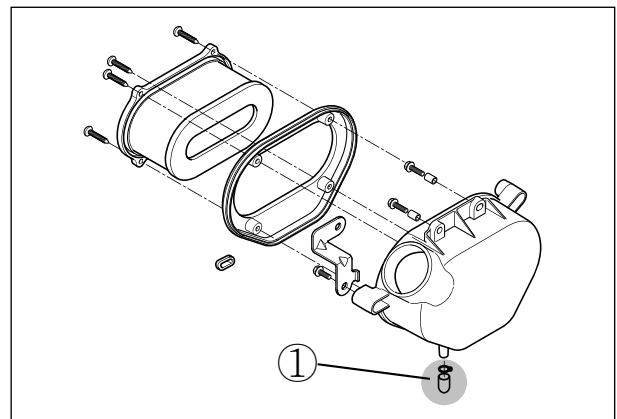

■ AIR CLEANER CHAMBER OIL DRAIN PLUG

Inspect the plug ② and drain water and oil at the periodic maintenance interval.

The air cleaner chamber oil drain plug ② is located beneath the air cleaner chamber.

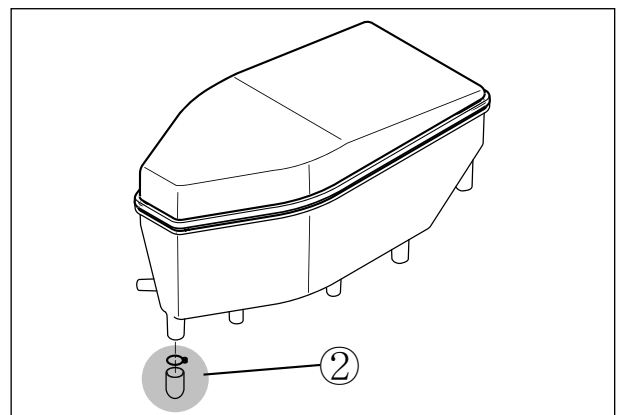

ENGINE IDLE SPEED

Inspect Interval

Inspect Initial 1,000 km and Every 6,000 km thereafter.

NOTE

Make this inspection when the engine is hot.

- Connect an engine tachometer to the high tension cord.
Start the engine and inspect the engine idle speed between specified range.

Engine idle speed	1,400 ~ 1,600 rpm
--------------------------	-------------------

 **Engine tachometer : 09900-26006**

CAUTION

Never operate the idle screw ① to avoid variations of the carburetion setting.

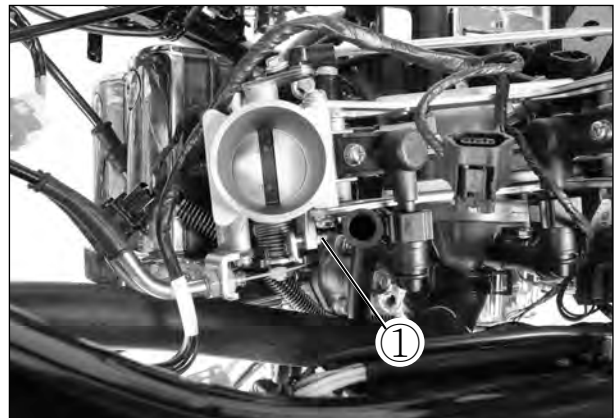

THROTTLE CABLE PLAY

Inspect Interval

Inspect Initial 1,000 km and Every 6,000 km thereafter.

This motorcycle has a twin throttle cable system. Cable ① is for throttle cable and cable ② is for returning cable. There should be 0.5 ~ 1.0 mm (0.02 ~ 0.04 in) play on the throttle cable.

To adjust the throttle cable play :

- Hold the motorcycle vertically.
- Uncover the protection.
- Loosen the lock nut ② of the returning cable ③ and fully turn in the adjuster ④.
- Loosen the lock nut ⑤ of the throttle cable ①.
- Turn the adjuster ⑥ in or out until the throttle cable play is between 0.5 ~ 1.0 mm (0.02 ~ 0.04 in).
- Tighten the lock nut ④ while holding the adjuster ⑥.
- While holding the throttle grip at the fully closed position, slowly turn out the adjuster ③ of the returning cable ② until resistance is felt.
- Tighten the lock nut ② while holding the adjuster ③.
- Check free play again.
- Cover the protection.

Throttle cable play	0.5 ~ 1.0 mm (0.02 ~ 0.04 in)
----------------------------	-------------------------------

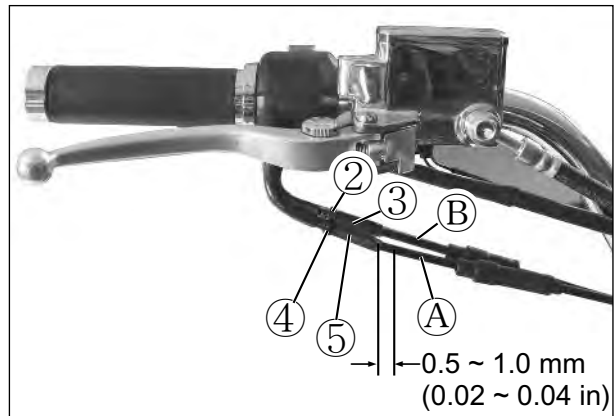

CAUTION

Inadequate throttle cable play can cause engine speed to rise suddenly when you turn the throttle grip. This can lead to loss of rider control.

CAUTION

After the adjustment is completed, check that throttle grip movement does not raise the engine idle speed and that the throttle grip returns smoothly and automatically.

FUEL HOSE

Inspect Interval

*Inspect Initial 1,000 km and Every 6,000 km thereafter.
Replace every 4 years.*

- Remove the seat. (Refer to page 8-1)
 - Remove the fuel tank. (Refer to page 5-2)
 - Remove the frame cover. (Refer to page 8-2)
- Inspect the fuel hoses for damage and fuel leakage.
If any defects are found, the fuel hoses must be replaced.



CLUTCH

Inspect Interval

Inspect Initial 1,000 km and Every 6,000 km thereafter.

Clutch play should be 2 mm (0.08 in) as measured at the clutch lever holder before the clutch begins to disengage.
If the play in the clutch is incorrect, adjust it in the following way :

- A basis adjustment be allowed by the clutch lever adjuster ②.
- Uncover the rubber boot ⑤.
- Loosen the lock nut ① counter-clockwise.
- Turn the clutch lever adjuster ② in or out to acquire the specified play.
- After end of adjustment, tighten the lock nut ① clockwise fully and cover the rubber boot ⑤.
- If not adjust by the clutch lever adjuster ②, adjust by the clutch cable adjuster ④.
- Loosen the clutch cable adjuster lock nut ③.
- Turn the clutch cable adjuster ④ in or out to acquire the specified play.
- After end of adjustment, tighten the lock nut ③.
- The clutch cable should be lubricated with a light weight oil whenever it is adjusted.

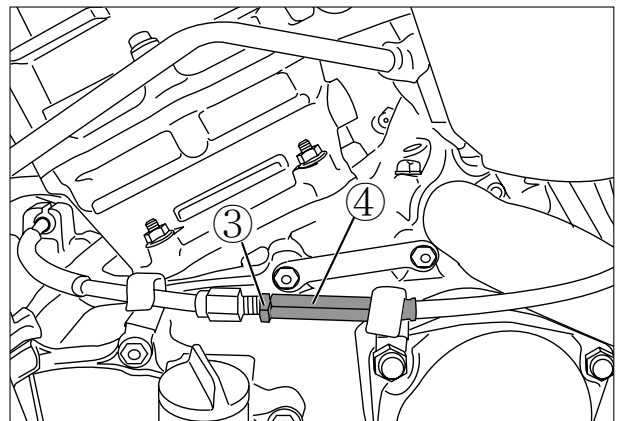
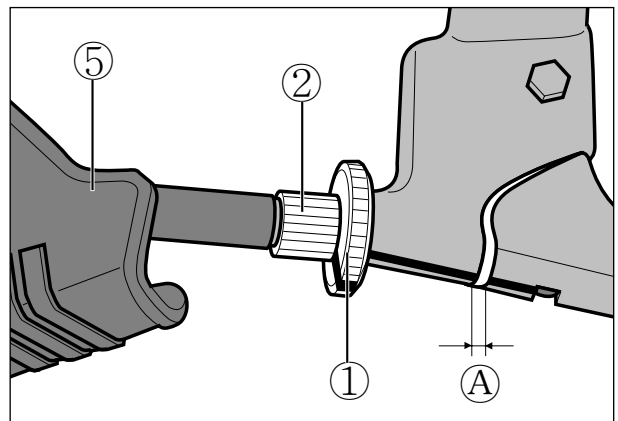

Clutch cable play Ⓐ	2 mm (0.08 in)
----------------------------	----------------

▣ GEARSHIFT LEVER HEIGHT ADJUSTMENT

- Loosen the lock nut ⑥.
- With the link rod ⑦ turned, adjust the gearshift lever height.
- Tighten the lock nut ⑥.

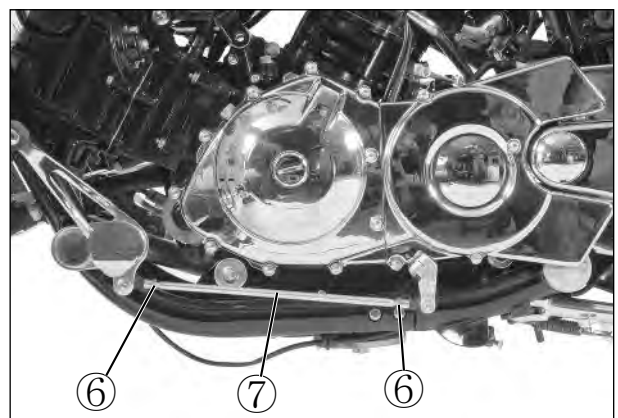

■ FOOTREST POSITION ADJUSTMENT

『ST7』 has 2 type of the footrest position, right and left.

To change the position, remove the footrest mounting bolt ①, footrest boss cap ② and bolt ③.

Install the bolt ① to the desired position and footrest boss cap ②, bolt ③ to the position ㉚.

『ST7』 is delivered from the factory on position ㉚.

㉚

⚠ WARNING

When adjusting the footrest position, the footrest mounting bolt be torque to the proper specification.

If they are not, the footrest can come off unexpectedly.

🔧 Footrest mounting bolt

: 40 ~ 60 N · m (4.0 ~ 6.0 kgf · m)

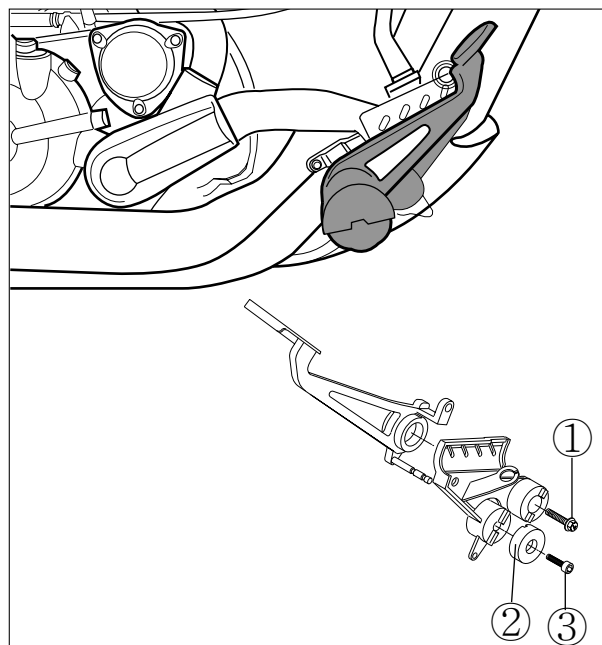

POSITION ㉚

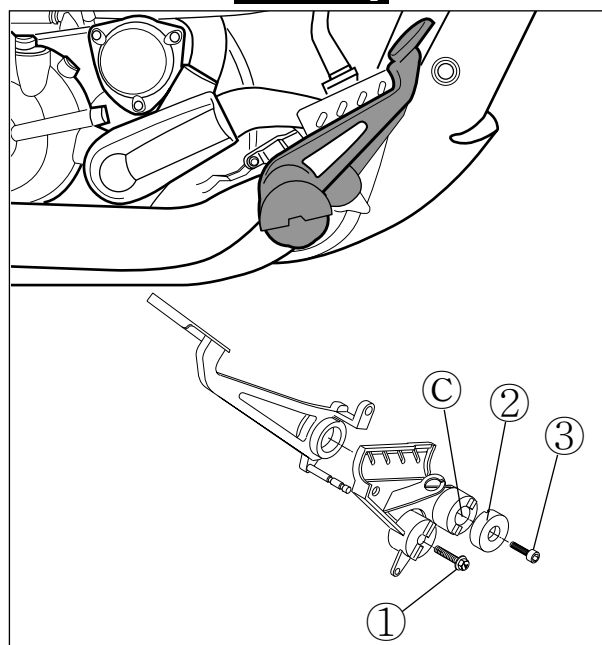

POSITION ㉛

■ GEARSHIFT LINK ROD

When the footrests in position ㉛, exchange the gearshift link rod for appropriate riding position.

● Position ㉚

: Install the gearshift link rod ④

● Position ㉛

: Install the gearshift link rod ⑤

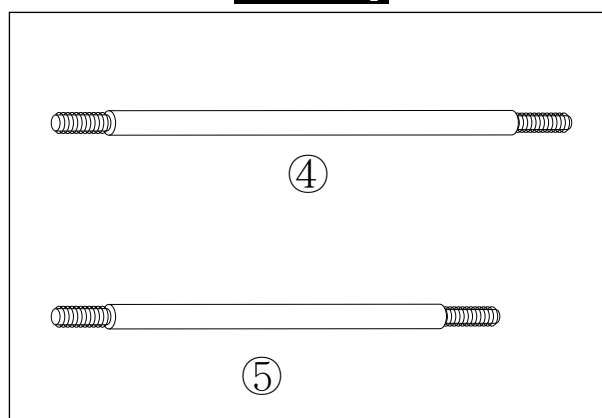
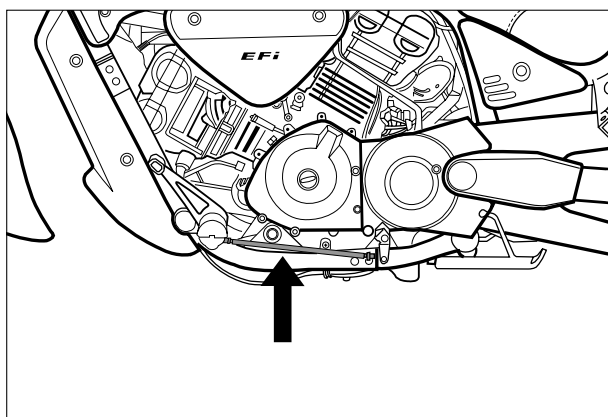

ENGINE OIL

Inspect Interval

Replace Initial 1,000 km and Every 6,000 km thereafter.

Necessary amount of engine oil	
Oil change	3,000 ml
Oil and filter change	3,200 ml
Engine overhaul	3,400 ml
Engine oil type	SAE 10W/40 API Over SL

The oil should be changed while the engine is warm. Oil filter replacement at the above intervals, should be together with the engine oil change.

- Keep the motorcycle upright.
- Place an oil pan below the engine, and drain the oil by removing the filler cap ① and drain plug ②.
- Tighten the drain plug ② to the specified torque, and pour fresh oil through the oil filler. Use an API classification of Over SL oil with SAE 10W/40 viscosity.

 Oil drain plug : 21 N · m (2.1 kgf · m)

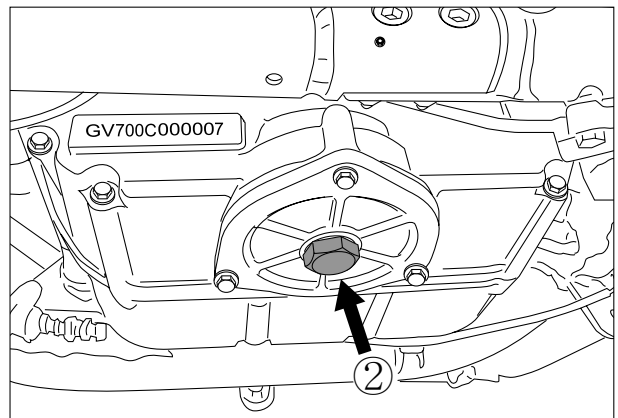
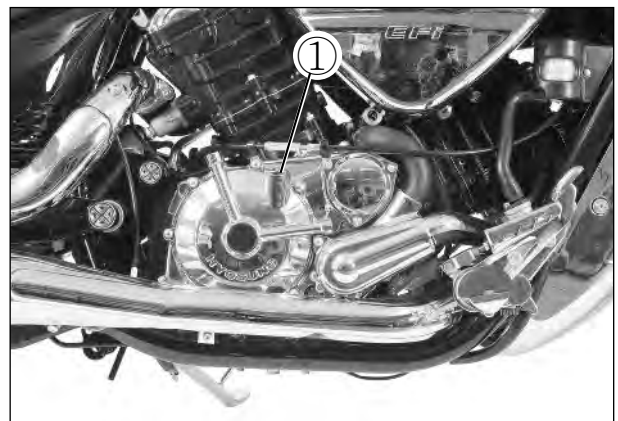

2-13 PERIODIC MAINTENANCE

- Start up the engine and allow it to run for several minutes at idling speed.
- Turn off the engine and wait about three minutes, then check the oil level through the inspection window.
If the level is below mark “L”, add oil to “F” level.
If the level is above mark “F”, drain oil to “F” level.

CAUTION

Never operate the motorcycle if the engine oil level is below the “Lower line mark (L)” in the inspection window. Never fill the engine oil above the “Upper line mark (F)”.

Engine oil level being most suitable about 1 mm under the “Upper line mark (F)” of the engine oil lens. In case of the engine oil pouring in excessively, the engine output being made insufficient. Be careful not to pour the engine oil excessively into engine.

CAUTION

Necessarily, confirm and clean the oil strainer  when replace the engine oil (specially, when first replacement).

CAUTION

More frequent servicing may be performed on motorcycles that are used under severe conditions.

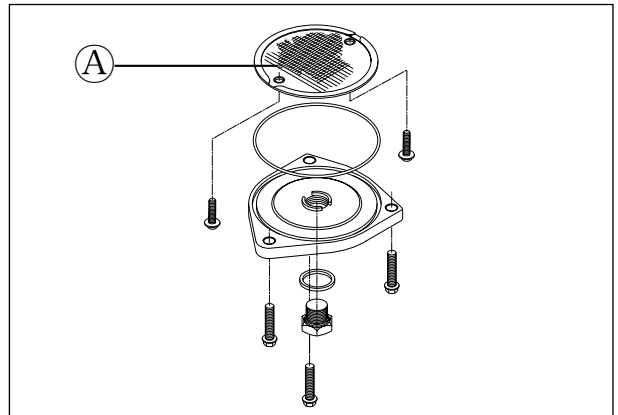

ENGINE OIL FILTER

Inspect Interval

Replace Initial 1,000 km and Every 6,000 km thereafter.

- Drain the engine oil as described in the engine oil replacement procedure.
- Remove the oil filter cap ①.
- Remove the oil filter.
- Install the new O-ring ②.

- Install the new oil filter.
- Install the new O-ring ③ and spring ④ to the oil filter cap.
- Install the oil filter cap.

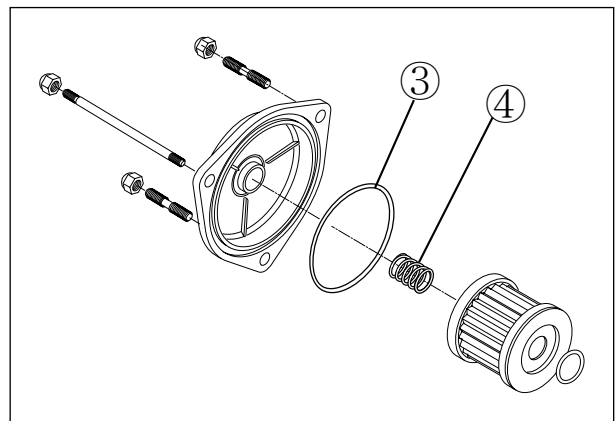
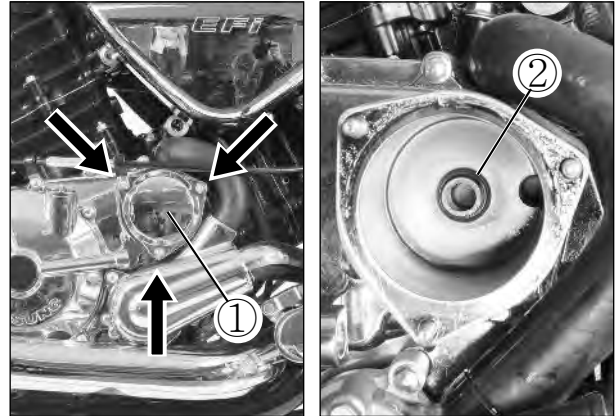

⚠ CAUTION

Before installing the oil filter cap, apply engine oil lightly to the new O-ring ③.

■ OIL FILTER INSTALLATION

⚠ CAUTION

When install the oil filter, necessarily, 'HYOSUNG' character and '16510HN910' part's NO. install to-ward the outside, otherwise can damage the engine.

⚠ WARNING

Engine oil and exhaust pipes can be hot enough to burn you.

Wait until the oil drain plug and exhaust pipes are cool enough to touch with bare hands before draining oil.

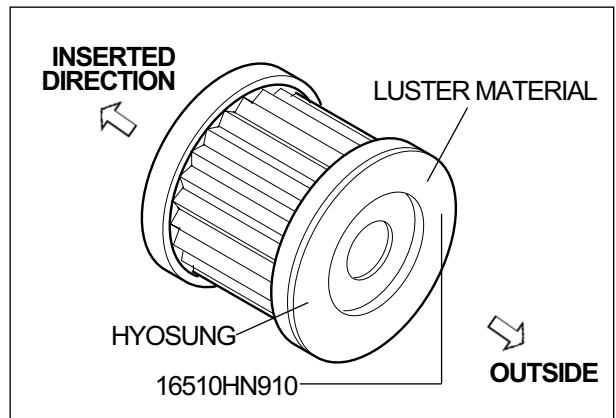

- Add new engine oil and check the oil level as described in the engine oil replacement procedure.

⚠ CAUTION

Use HYOSUNG MOTORS GENUINE OIL FILTER only, since the other make's genuine filters and after-market parts may differ filtering performance and durability, which could cause engine damage or oil leaks. Hyosung motors genuine oil filter is also not usable for the motorcycles.



DRIVE BELT

Inspect Interval

Inspect Every 1,000 km.

Visually check the drive belt for the possible defects listed below. (Support the motorcycle by the jack or block, turn the rear wheel slowly by hand with the transmission shifted to Neutral.)

- Edges of the belt for cuts or unusual wear patterns
- Outside ribbed surface of the belt for sign of stone puncture
- Roots of the belt teeth
- Sign of cracking at the base of the belt teeth
- Common types of belt wear and damage
- Improper belt adjustment

If any defects are found, the drive belt must be replaced.

Damage to the drive belt means that the pulleys may also be damaged.

If any defects are found, the pulleys must be replaced.

ADJUSTMENT OF DRIVE BELT SLACK

- Loosen the rear axle (A).
- Loosen the lock nuts (B, C).
- Loosen or tighten both belt adjusters (D, E) until the belt has specification of slack in the belt case inspecting hole (H). The marks (F, G) on both belt adjusters must be at the same position on the scale to ensure that the front and rear wheels are correctly aligned.
- Inspect the drive belt slack by the belt case inspecting hole (H) at the left side of the motorcycle.

DRIVE BELT SLACK (4.5kgf of Force)

When the rear tire is touched the ground	4.5 ~ 5.5 mm (0.18 ~ 0.22 in)
When the rear tire is not touched the ground	5.0 ~ 6.0 mm (0.20 ~ 0.24 in)

- Place the motorcycle on jack or block for accurate adjustment.

CAUTION

Improper jacking may cause damage to the frame or engine.

- After adjusting the drive belt, tighten the rear axle (A) to the specified torque.

Rear axle

: 90 ~ 140 N · m (9.0 ~ 14.0 kgf · m)

- Tighten both belt adjuster lock nuts (B, C) securely.

NOTE

When replacing the drive belt, replace the drive belt and pulleys as a set.

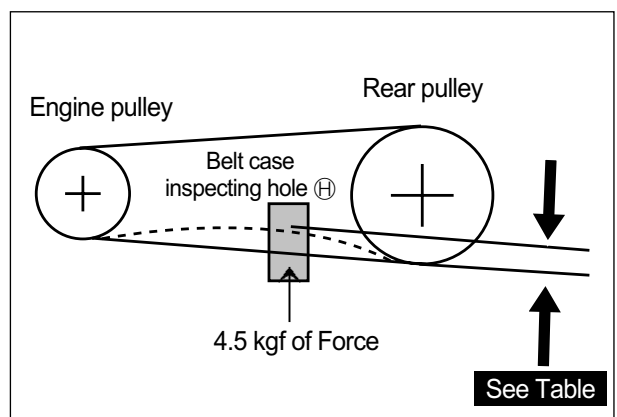
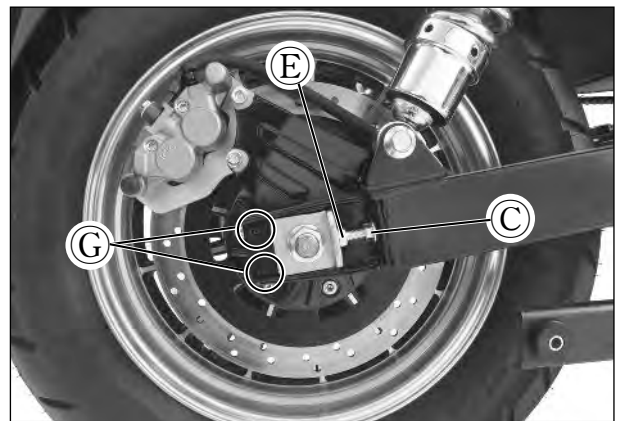
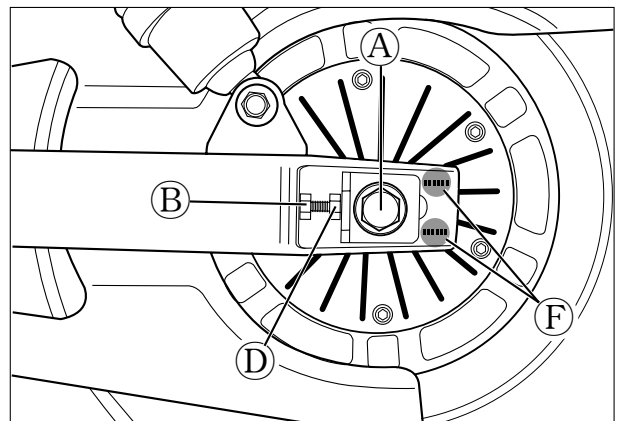

- Recheck the drive belt slack after tightening the rear axle.

⚠ WARNING

Be careful not to touch the muffler when it is hot : a hot muffler can burn you.

⚠ CAUTION

The drive belt for this motorcycle is made of the special material.

The belt should be replaced with a “Poly chain belt” for 『ST7』.

Use of another belt may lead to premature belt failure.

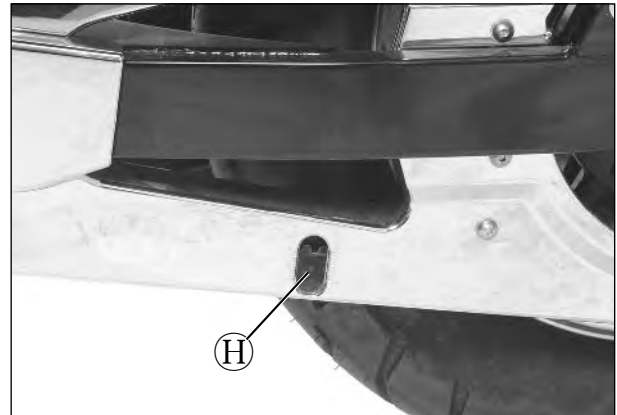

■ CAUTION OF DRIVE BELT

When the drive belt was bent excessively, the belt inner cord is broken.

Never bend the drive belt under the specification of inner or back bend capacity.

BEND CAPACITY OF DRIVE BELT

Back	least 204 mm (8.04 in)
Inner	least 102 mm (4.02 in)

⚠ CAUTION

- ❖ Never bend or twist when the drive belt is kept or installed.
- ❖ If the drive belt was installed with driver forcedly, damage the drive belt.

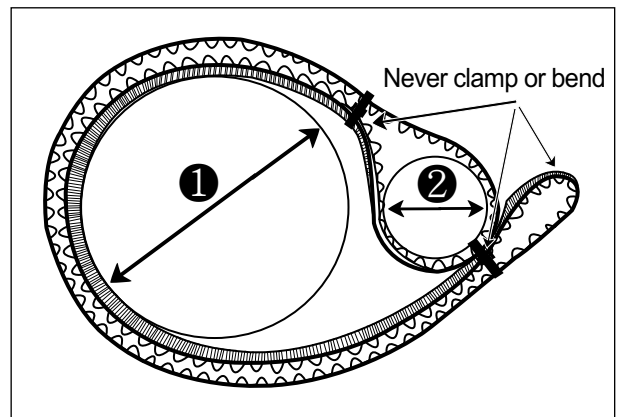

※ ① Back bend ② Inner bend

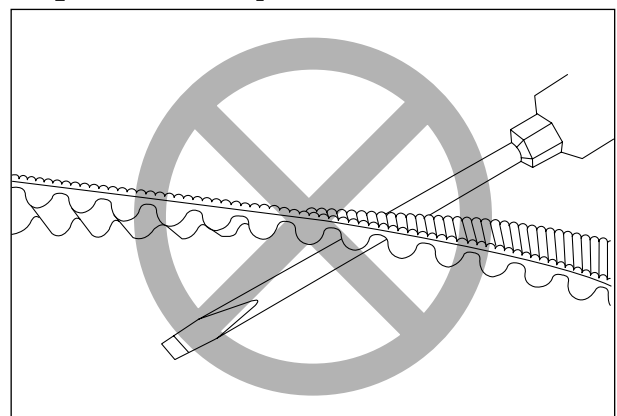

BRAKE SYSTEM

Inspect Interval

[BRAKE]

Inspect Initial 1,000 km and Every 6,000 km thereafter.

[BRAKE HOSES & BRAKE FLUID]

Inspect Initial 1,000 km and Every 6,000 km thereafter.

Replace the brake hoses Every 4 years,

Replace the brake fluid Every 2 years.

■ BRAKE FLUID LEVEL CHECK

- Keep the motorcycle upright and place the handlebars straight.
- Check the brake fluid level by observing the lower limit line (LOWER) on the front or rear brake fluid reservoir.
- When the level is below the lower limit line (LOWER), replenish with brake fluid that meets the following specification.



Specification and Classification

: DOT 4



WARNING

The brake system of this motorcycle is filled with a glycol-based brake fluid. Do not use or mix different types of fluid such as silicone-based or petroleum-based. Do not use any brake fluid taken from old, used or unsealed containers.

Never re-use brake fluid left over from the last servicing or stored for a long period.



WARNING

Brake fluid, if it leaks, will interfere with safe running and immediately discolor painted surfaces.

Check the brake hoses and hose joints for cracks and oil leakage before riding.

■ BRAKE PAD WEAR

The extend of brake pad wear can be checked by observing the grooved limit (A) on the pad. When the wear exceeds the grooved limit, replace the pads with new ones.



CAUTION

Replace the brake pad as a set, otherwise braking performance will be adversely affected.



CAUTION

Do not spill any brake fluid on the brake pad of disk.



Front Brake



Rear Brake

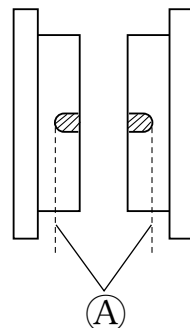

■ FRONT AND REAR BRAKE PAD REPLACEMENT

- Remove the brake caliper.

FRONT BRAKE

- Remove the brake pad mounting bolt's E-ring ①.
- Remove the brake pad mounting bolts ② and spring ③.

REAR BRAKE

- Remove the brake pad mounting bolts ④.
- Remove the brake pad spring.

⚠ CAUTION

Do not operate the brake lever or pedal while dismounting the pads.

- Remove the brake pads.
- To reassemble, reverse the above sequence.

- 🔧 Front brake caliper mounting bolt
 : 18 ~ 28 N · m (1.8 ~ 2.8 kgf · m)
- Rear brake caliper mounting bolt
 : 18 ~ 28 N · m (1.8 ~ 2.8 kgf · m)

NOTE

After replacing the brake pads, pump or press the brake lever or pedal few times to check for proper brake operation and then check the brake fluid level.



Front Brake

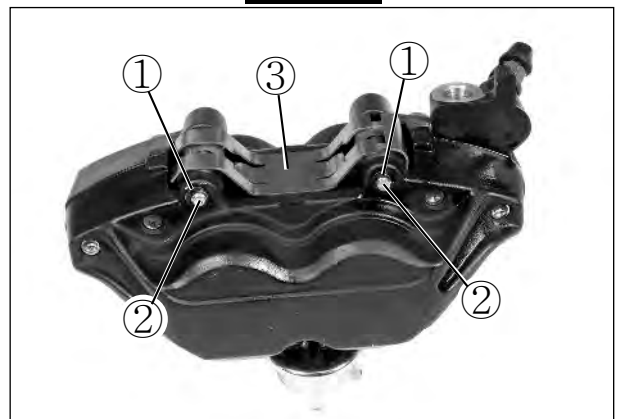

Rear Brake

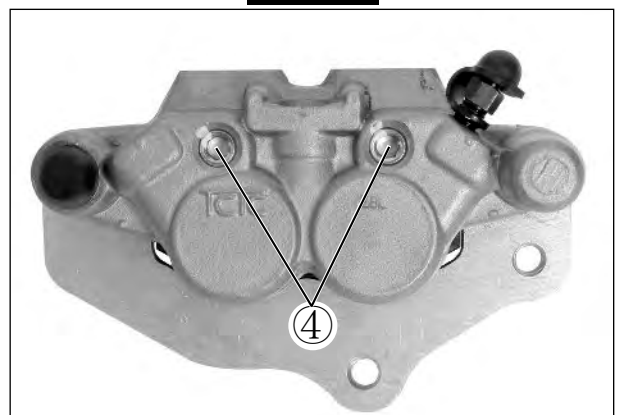

■ FRONT AND REAR BRAKE FLUID REPLACEMENT

- Place the motorcycle on a level surface and keep the handlebars straight.
- Remove the master cylinder reservoir cap and diaphragm.
- Suck up the old brake fluid as much as possible.
- Fill the reservoir with new brake fluid.

 **Specification and Classification**
: DOT 4

- Connect a transparent hose ① to the air bleeder valve and insert the other end of the hose into a receptacle.

- Loosen the air bleeder valve and pump the brake lever until the old brake fluid is completely out of the brake system.

- Close the air bleeder valve and disconnect the transparent hose. Fill the reservoir with new brake fluid to the upper line.
- Replace the rear brake's fluid with the same manner of the front brake.

 **Front brake caliper air bleeder valve**
: 6 ~ 8 N · m (0.6 ~ 0.8 kgf · m)
Rear brake caliper air bleeder valve
: 6 ~ 8 N · m (0.6 ~ 0.8 kgf · m)

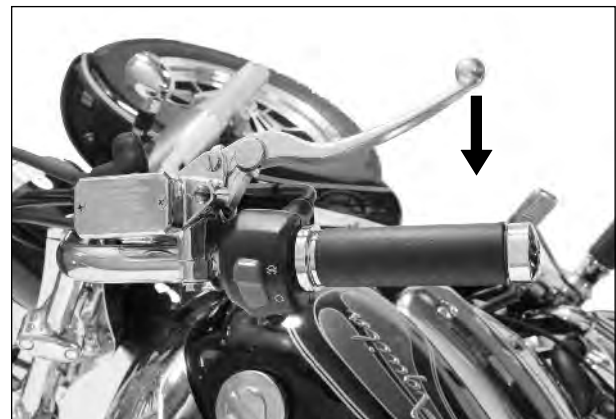

■ AIR BLEEDING OF THE BRAKE FLUID CIRCUIT

Air trapped in the brake fluid circuit acts like a cushion to absorb a large proportion of the pressure developed by the master cylinder and thus interferes with the full braking performance of the brake caliper. The presence of air is indicated by “sponginess” of the brake lever and also by lack of braking force. Considering the danger to which such trapped air exposes the machine and rider, it is essential that, after remounting the brake and restoring the brake system to the normal condition, the brake fluid circuit be purged of air in the following manner :

- Fill the master cylinder reservoir to top of the inspection window. Replace the reservoir cap to prevent dirt from entering it.
 - Attach a hose ① to the air bleeder valve, and insert the free end of the hose into a receptacle.
 - Bleed air from the brake system.
-
- Squeeze and release the brake lever several times in rapid succession and squeeze the lever fully without releasing it. Loosen the bleeder valve by turning it a quarter of a turn so that the brake fluid runs into the receptacle, this will remove the tension of the brake lever causing it to touch the handlebar grip. Then, close the air bleeder valve, pump and squeeze the brake lever, and open the valve. Repeat this process until the fluid flowing into the receptacle no longer contains air bubbles.

NOTE

While bleeding the brake system, replenish the brake fluid in the reservoir as necessary. Make sure that there is always some fluid visible in the reservoir.

- Close the air bleeder valve, and disconnect the hose. Fill the reservoir with brake fluid to the upper line.
- Bleed the rear brake's air with the same manner of front brake.

- **Front brake caliper air bleeder valve**
: 6 ~ 8 N · m (0.6 ~ 0.8 kgf · m)
- Rear brake caliper air bleeder valve**
: 6 ~ 8 N · m (0.6 ~ 0.8 kgf · m)

⚠ CAUTION

Handle brake fluid with care : the fluid reacts chemically with paint, plastics, rubber materials, etc.

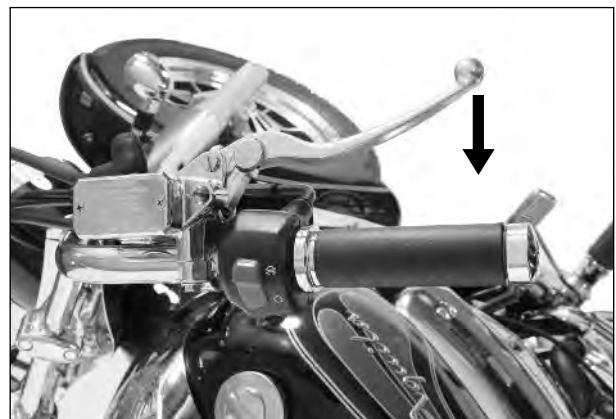

2-21 PERIODIC MAINTENANCE

■ FRONT BRAKE LAMP SWITCH

The front brake lamp switch ① is located beneath the front brake lever. Loosen the switch fitting screws and adjust the timing by moving the switch body forward or backward.

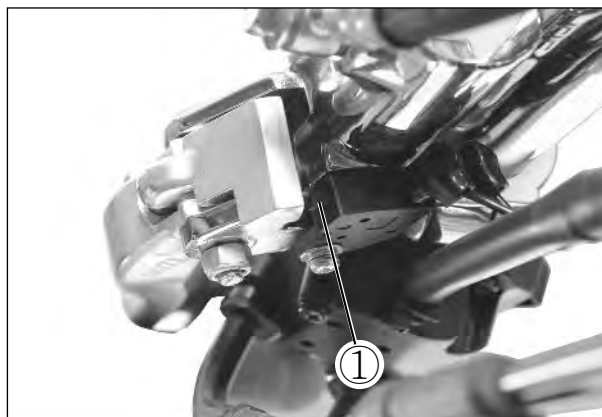

■ REAR BRAKE LAMP SWITCH

Adjust the rear brake lamp switch ② so that the brake lamp will come on just before pressure is felt when the brake pedal is depressed.

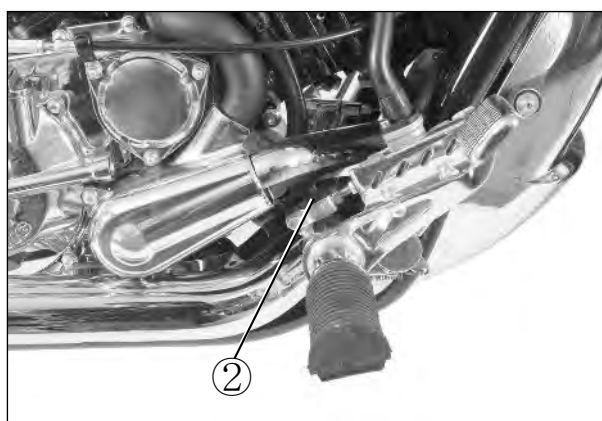

STEERING

Inspect Interval

Inspect Initial 1,000 km and Every 6,000 km thereafter.

Steering should be adjusted properly for smooth turning of handlebars and safe running. Overtight steering prevents smooth turning of the handlebars and too loose steering will cause poor stability. Check that there is no play in the steering stem while grasping the lower fork tubes by supporting the machine so that the front wheel is off the ground, with the wheel straight ahead, and pull forward. If play is found, perform steering stem nut adjustment as described in page 8-33 of this manual.



FRONT FORK

Inspect Interval

Inspect Every 6,000 km.

Inspect the front forks for oil leakage, scoring or scratches on the outer surface of the inner tubes. Replace any defective parts, if necessary.



REAR SUSPENSION

Inspect Interval

Inspect Every 6,000 km.

Inspect the rear shock absorber for oil leakage and mounting rubbers including engine mounting for wear and damage. Replace any defective parts, if necessary. (Refer to page 8-46)



TIRE

Inspect Interval

Inspect Initial 1,000 km and Every 6,000 km thereafter.

■ TIRE TREAD CONDITION

Operating the motorcycle with excessively worn tires will decrease riding stability and can lead to loss of control.

- Inspect shortage of tire thread's depth by the 『tire wear indicator』.
- Replace the front and rear tires at once when appear the 『tire wear indicator』.

■ TIRE PRESSURE

If the tire pressure is too high or too low, steering will be adversely affected and tire wear increased. Therefore, maintain the correct tire pressure for good enter key roadability or shorter tire life will result. Cold inflation tire pressure is as follows.

COLD INFLATION TIRE PRESSURE	SOLO RIDING			DUAL RIDING		
	KPa	kgf/cm ²	psi	KPa	kgf/cm ²	psi
Front	200	2.00	30.0	225	2.25	33.0
Rear	225	2.25	33.0	250	2.50	36.0

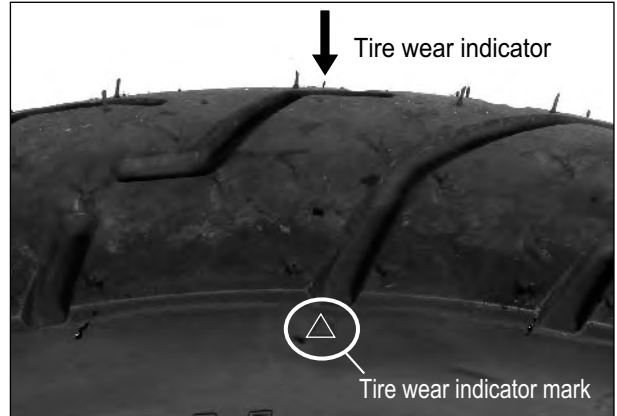

⚠ CAUTION

The standard tire on 『ST7』 is
 120/80 - 16 60H for front and
 170/80 - 15 77H for rear.

The use of tires other than those specified may cause instability. It is highly recommended to use a HYOSUNG Genuine Tire.

CHASSIS BOLTS AND NUTS

Inspect Interval

Tighten Initial 1,000 km and Every 6,000 km thereafter.

Check that all chassis bolts and nuts are tightened to their specified torque. (Refer to page 9-19)

ENGINE COOLANT

Inspect Interval

Replace Every 2 years.

ENGINE COOLANT LEVEL CHECK

- Keep the motorcycle upright.
- Check the engine coolant level by observing the “F” (Full) and “L” (Low) level lines on the engine coolant reserve tank.
- If the level is below the “L” (Low) level line, add engine coolant until the level reaches the “F” (Full) level line, through the engine coolant reserve tank filler ①.

Engine coolant capacity	
Reserve tank side	230 ml
Radiator side	430 ml
Engine side	940 ml

⚠ WARNING

- ❖ Engine coolant may be harmful if swallowed or if it comes in contact with the skin or eyes. If engine coolant gets into the eyes or contacts the skin, flush the eyes or wash the skin thoroughly, with plenty of water. If engine coolant is swallowed, induce vomiting and call a physician immediately.
- ❖ Keep out of the reach of children and animals.

⚠ CAUTION

- ❖ Use distilled water only. Water other than distilled water can corrode and clog the aluminum radiator.
- ❖ The 50 : 50 mixture of distilled water and ethylene glycol anti-freeze will provide the optimum corrosion protection and excellent heat protection, and will protect the cooling system from freezing at temperatures above -31°C (-24°F).

NOTE

Bleed air from the cooling circuit when the engine overheats.

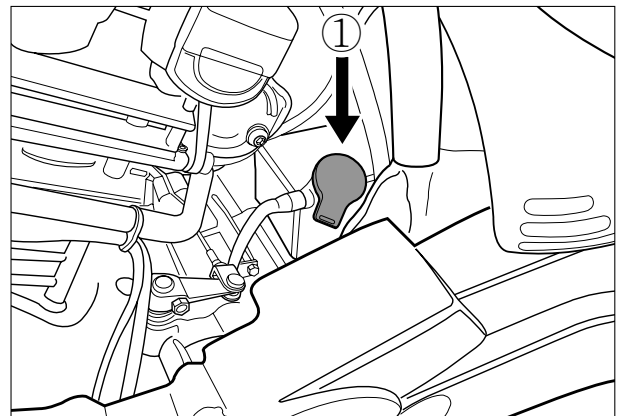
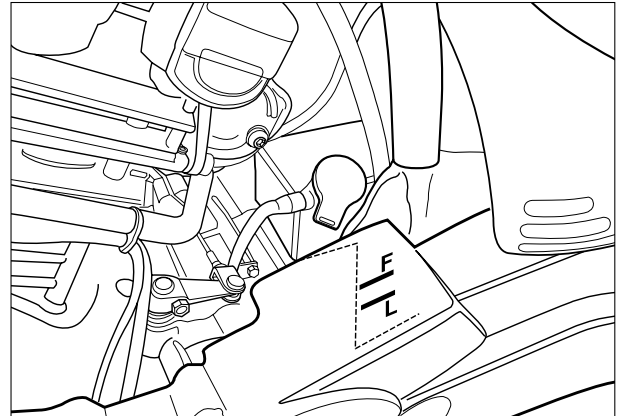

■ OPEN THE RADIATOR CAP

Remove the right frame head cover ① to operate the radiator cap ③.

To disassemble the right frame head cover ①, remove the two mounting bolts ②.

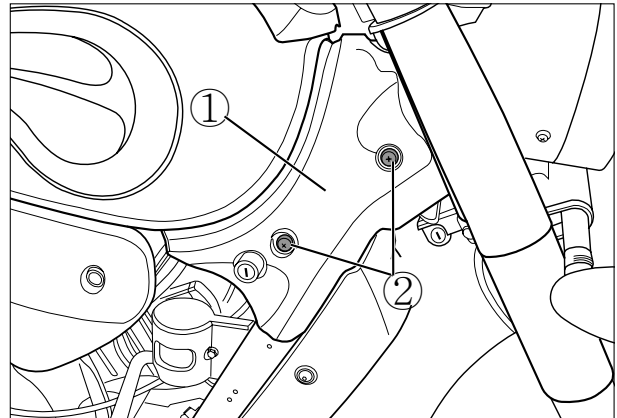

⚠ WARNING

You can be injured by scalding fluid or steam if you open the radiator cap when engine is hot. After the engine cools, wrap a thick cloth around cap and carefully remove the cap by turning it a quarter to allow pressure to escape and then turn the cap all the way off.

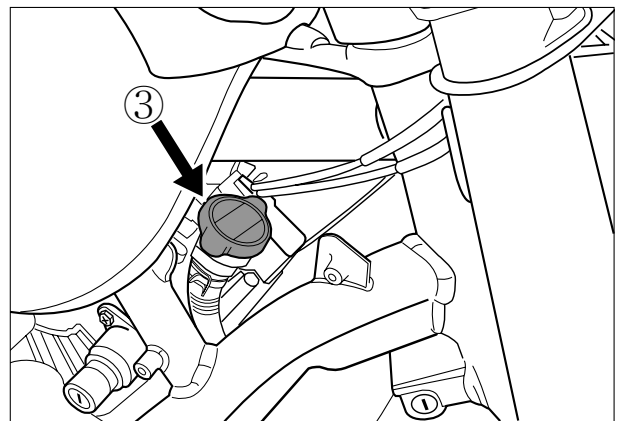

■ ENGINE COOLANT REPLACEMENT

⚠ WARNING

Do not open the radiator cap when the engine is hot, as you may be injured by escaping hot liquid or vapor.

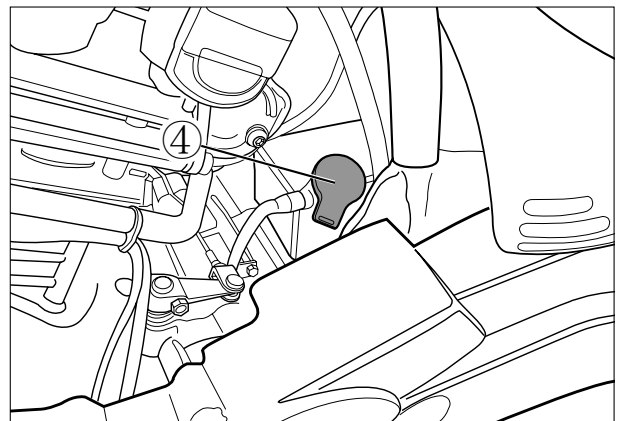

- Remove the right frame head cover ①.
- Remove the radiator cap ③.
- Remove the coolant reserve tank filler cap ④.
- Place a pan below the water pump, and then drain the engine coolant by removing the drain bolt ⑤.
- Flush the radiator with fresh water, if necessary.
- Tighten the coolant drain bolt ⑤ to the specified torque.

🔧 Coolant drain bolt

: 11 ~ 14 N · m (1.1 ~ 1.4 kgf · m)

- Pour the engine coolant through the radiator cap inlet.

Engine coolant capacity	
Reserve tank side	230 ml
Radiator side	430 ml
Engine side	940 ml

NOTE

For engine coolant information, refer to page 6-1



- Bleed the air from the engine coolant circuit as following procedure.

■ AIR BLEEDING THE COOLING CIRCUIT

- Add engine coolant up to the radiator cap inlet.
- Support the motorcycle upright.
- Slowly swing the motorcycle, right and left, to bleed the air trapped in the cooling circuit.
- Add engine coolant up to the radiator cap inlet.

- Start up the engine and bleed air from the radiator cap inlet completely.
- Add engine coolant up to the radiator cap inlet.
- Repeat the above procedure until no air bleed from the radiator cap inlet.

- Close the radiator cap securely.
- After warming up and cooling down the engine several times, add the engine coolant up to the "F" (Full) level line of the reserve tank.

⚠ CAUTION

Repeat the above procedure several times and make sure that the radiator is filled with engine coolant up to the "F" (Full) level line of the reserve tank.

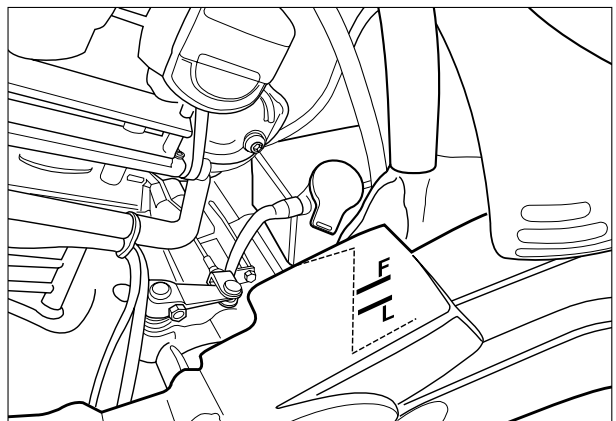

RADIATOR HOSE

Inspect Interval

*Inspect Every 6,000km,
Replace Every 4 years.*

Inspect the radiator hoses for crack, damage or engine coolant leakage.

If any defects are found, replace the radiator hoses with new ones.

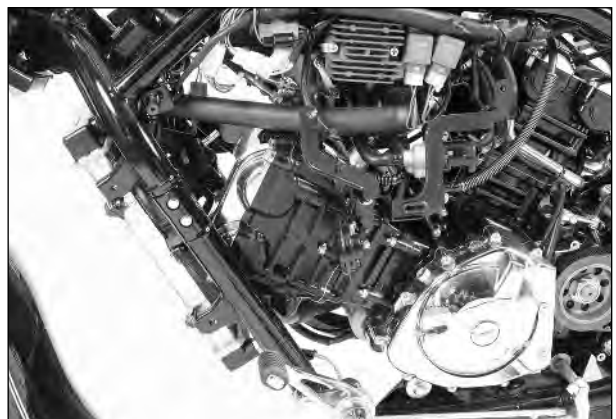

COMPRESSION PRESSURE

The compression pressure reading of a cylinder is a good indicator of its internal condition.

The decision to overhaul the cylinder is often based on the results of a compression test. Periodic maintenance records kept at your dealership should include compression pressure reading for each maintenance service.

Compression pressure	
Standard	14 kgf/cm ² (at 500 rpm)
Service limit	12 kgf/cm ² (at 500 rpm)
Difference	2 kgf/cm ² (at 500 rpm)

■ COMPRESSION TEST PROCEDURE

NOTE

- ❖ Before testing the engine for compression pressure, make sure that the cylinder head bolts are tightened to the specified torque values and valves are properly adjusted.
- ❖ Have the engine warmed up by idling before testing.
- ❖ Be sure that the battery used is in fully-charged condition.

Remove the parts concerned and test the compression pressure in the following manner.

- Loosen the radiator cover mounting bolts from the frame.
- Loosen the radiator mounting bolts.

⚠ WARNING

The hot radiator and the hot engine can burn you. Wait until the radiator and the engine are cool enough to touch.

⚠ CAUTION

- ❖ Be careful not to damage the radiator fins.
- ❖ Do not extract the radiator hose.

- Remove the seat and fuel tank. (Refer to page 5-2)
- Remove all the spark plugs.
- Fit the compression gauge in one of the plug holes, while taking care that the connection is tightened.
- Keep the throttle grip in full-open position.
- Crank the engine a few seconds with the starter, and record the maximum gauge reading as the compression of cylinder.

 **Compression gauge : 09915-64511**

Low compression pressure can indicate some of the following conditions :

- Excessively worn cylinder wall
- Worn-down piston or piston rings
- Piston rings stuck in grooves
- Poor seating of valves
- Ruptured or otherwise defective cylinder head gasket

NOTE

When the compression pressure goes below specification, check the engine for conditions listed above.

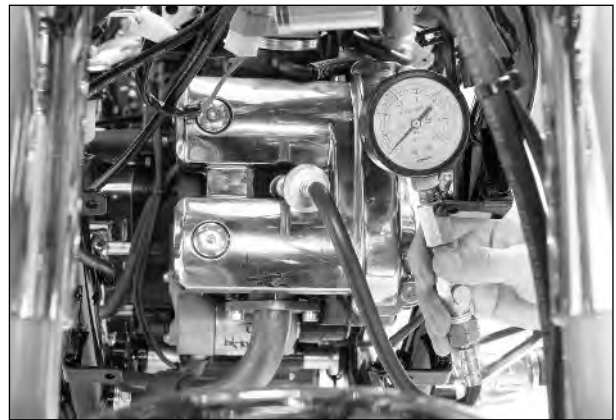

Overhaul the engine in the following cases :

- Compression pressure in one of the cylinder is less than 12 kgf/cm².
- The difference in compression pressure between two cylinder is more than 2 kgf/cm².
- All compression pressure readings are nearly 12 kgf/cm² even when they measure more than 12 kgf/cm².

OIL PRESSURE

Check the engine oil pressure periodically. This will give a good indication of the condition of the moving parts.

Oil pressure	Standard
	2.0 ~ 6.0 kgf/cm ² (at 60 °C · 3,000 rpm)

If the engine oil pressure is lower or higher than the specification, the following causes may be considered.

■ LOW OIL PRESSURE

- Clogged oil filter
- Oil leakage from the oil passage
- Damaged O-ring
- Defective oil pump
- Combination of above items

■ HIGH OIL PRESSURE

- Engine oil viscosity is too high
- Clogged oil passage
- Combination of the above items

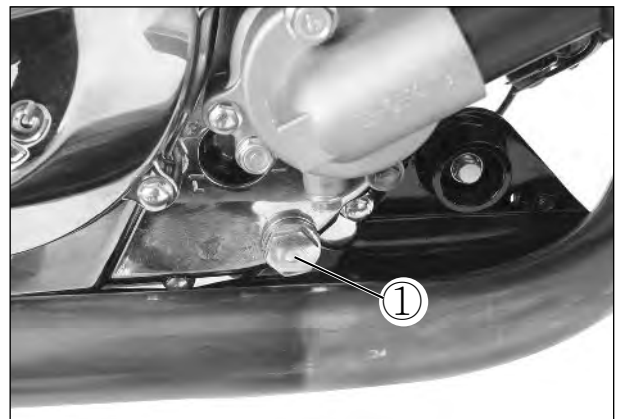

■ OIL PRESSURE TEST PROCEDURE

Check the engine oil pressure in the following manner.

- Remove the oil check plug ① and install the adapter of the oil pressure gauge at the removed position.
- Connect an engine tachometer.
- Warm up the engine as follows :
 Summer : 10 min. at 2,000 rpm.
 Winter : 20 min. at 2,000 rpm.
- After warming up, increase the engine speed to 3,000 rpm. (with the engine tachometer), and read the oil pressure gauge.

 **Engine tachometer : 09900-26006**
Oil pressure gauge : 09915-74511

- Tighten the engine oil check plug ① to the specified torque.

 **Engine oil check plug**
: 18 N · m (1.8 kgf · m)

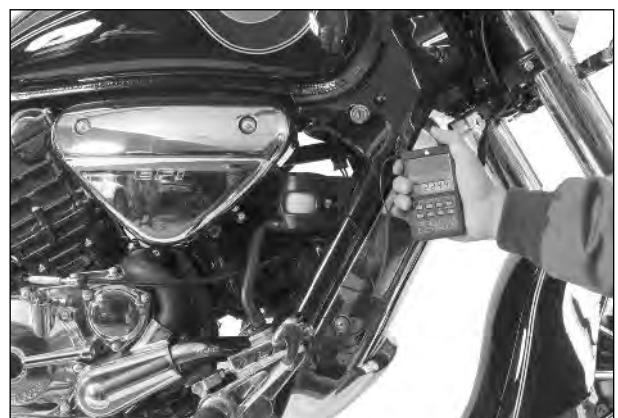

ENGINE

CONTENTS

ENGINE REMOVAL AND REMOUNTING	3- 1
ENGINE REMOVAL	3- 1
ENGINE REMOUNTING	3- 9
ENGINE DISASSEMBLY	3-11
STARTER MOTER	3-11
THERMOSTAT	3-12
CYLINDER HEAD COVER	3-12
PISTON	3-16
MAGNETO COVER	3-16
MAGNETO ROTOR	3-17
CLUTCH COVER	3-18
CLUTCH	3-19
PRIMARY DRIVE GEAR	3-20
OIL PUMP	3-20
GEARSHIFT SHAFT	3-21
ENGINE COMPONENT INSPECTION AND SERVICE	3-23
ENGINE REASSEMBLY	3-41

CAUTION

- ❖ Mark an identification of assembly location on each removed part so that each will be restored to the original position during reassembly.
- ❖ Wash clean and dry the removed parts before inspecting and measuring.
- ❖ Oil the rotating or sliding parts before assembly.
- ❖ Make sure to use the correct type of lubricant where specified.
- ❖ Check that each rotating or sliding part moves or operates smoothly after assembly.
- ❖ Make sure to follow the bolt tightening order where specified.
- ❖ If the correct length of the bolt is confused when tightening the crankcase or cover, insert all the bolts and check that the tightening margin is equal in each bolt.

ENGINE REMOVAL AND REMOUNTING

ENGINE REMOVAL

NOTE

If the engine is dirtied, wash the machine with a suitable cleaner before removing the engine.

- Remove the seat. (Refer to page 8-1)
- Remove the fuel tank. (Refer to page 5-2)
- Remove the frame cover. (Refer to page 8-2)
- Disconnect the battery \ominus lead wire ①.

⚠ CAUTION

First, disconnect the \ominus lead wire.

- Drain engine oil. (Refer to page 2-12)
- Drain engine coolant. (Refer to page 2-25)

■ AIR CLEANER

- After loosening the two screws ②, remove the air cleaner cover ③.
- Loosen the two mounting bolts ④.

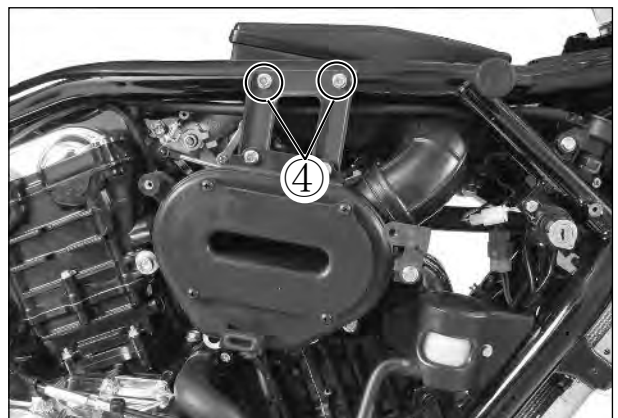
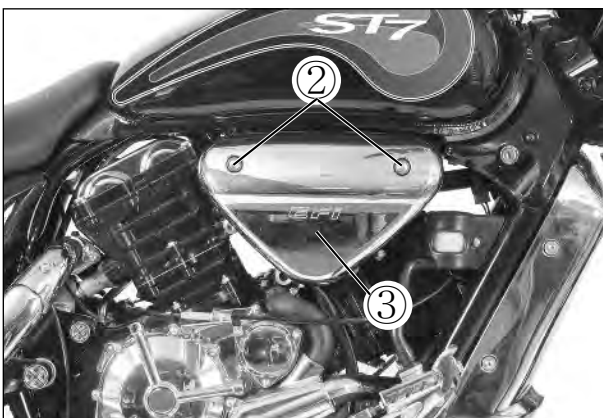
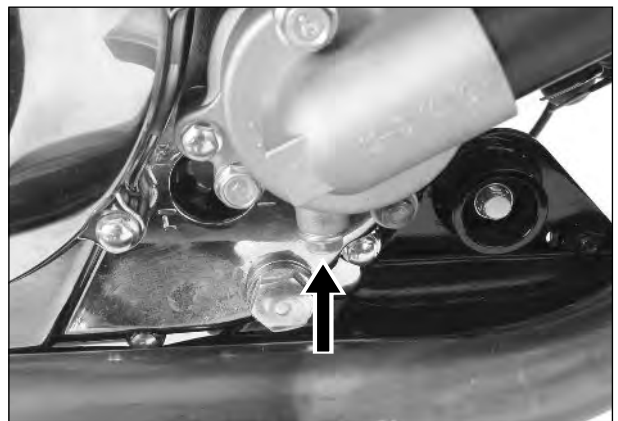
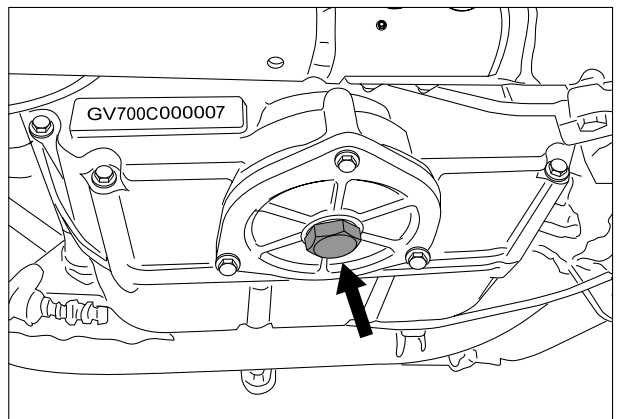

- With the bolt removed, take out the air cleaner chamber.

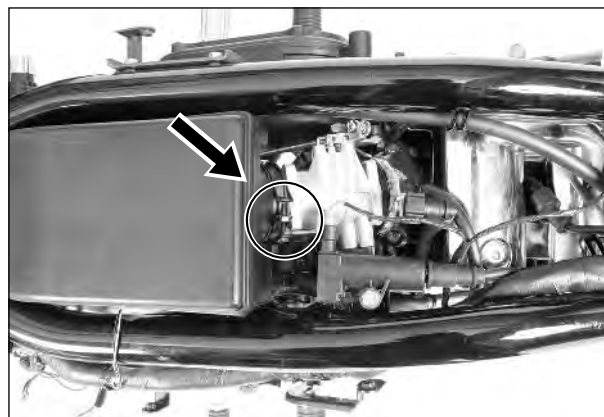
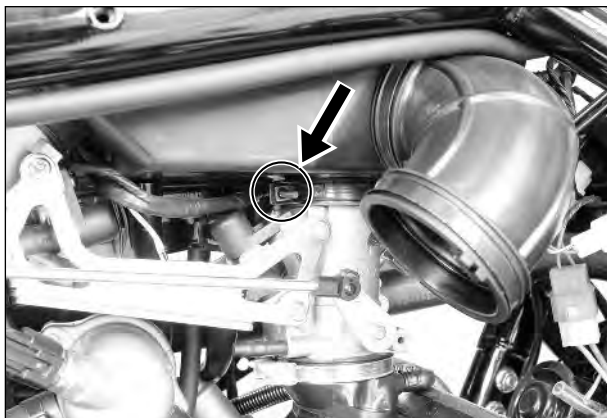

■ COOLING FAN

- After removing the two mounting bolts ②, remove the right frame head cover ①.

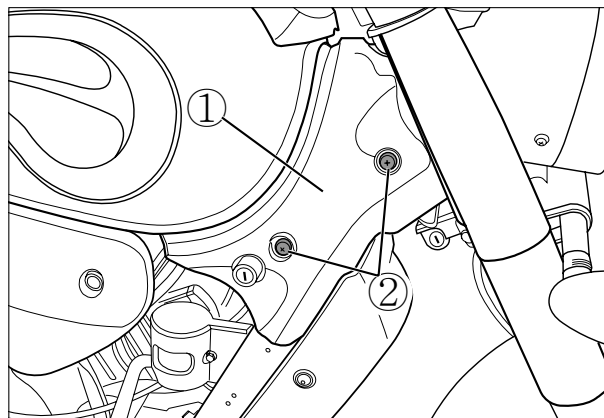

- Remove the radiator cap case and cap case bolt ③.



- Remove the four radiator cover mounting bolts.
- Remove the radiator cover ④.

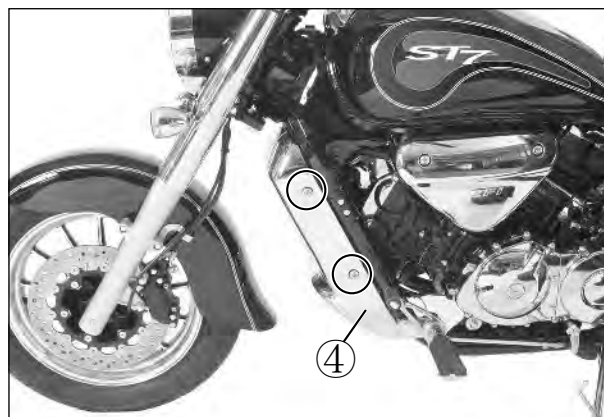

3-3 ENGINE

- Disconnect the radiator outlet hose ①.

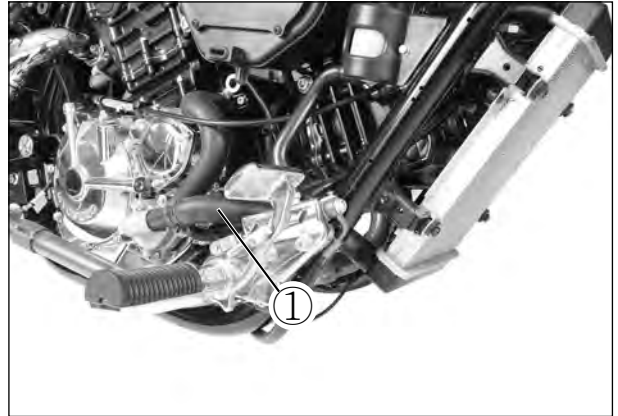

- Remove the radiator mounting bolts.

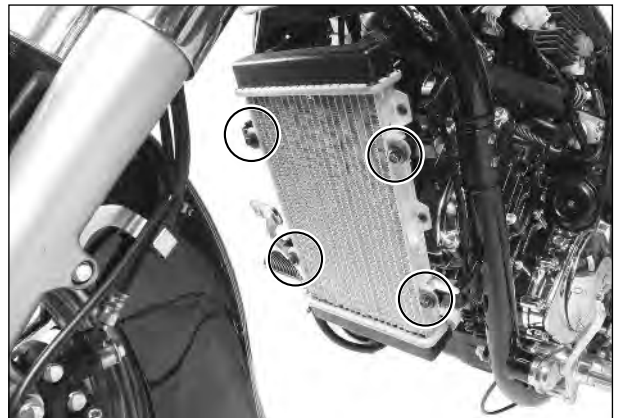

- Disconnect the cooling fan thermo-switch lead wire coupler ②.
- Disconnect the radiator inlet hose ③.

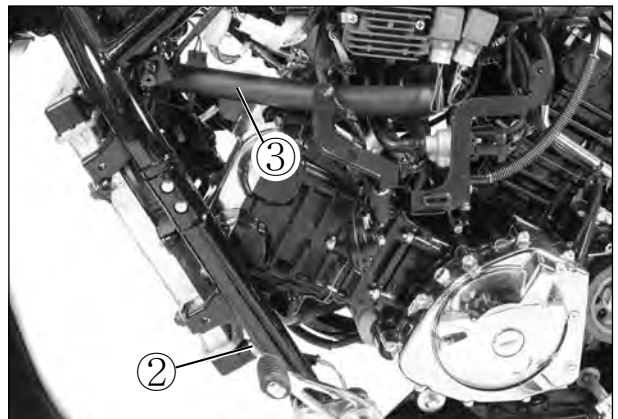

- Disconnect the reserve tank hose ④.
- Disconnect the cooling fan motor lead wire coupler ⑤.
- Remove the radiator.

 **CAUTION**

Be careful not to bend the radiator fin.

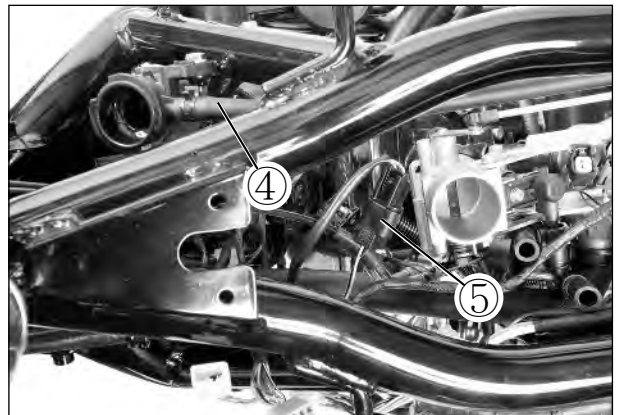

■ SENSORS

- Remove the all sensor couplers.
(Refer to chapter 4 and 5)

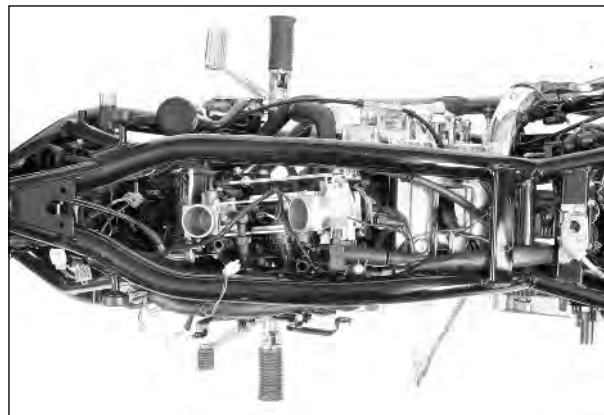

- Disconnect the fuel injector hoses ①.

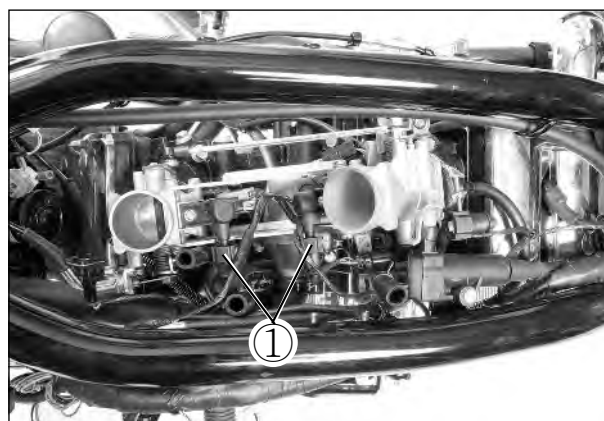
**■ THROTTLE BODY**

- Remove the throttle body after removing the intake pipes. (Refer to page 5-7)

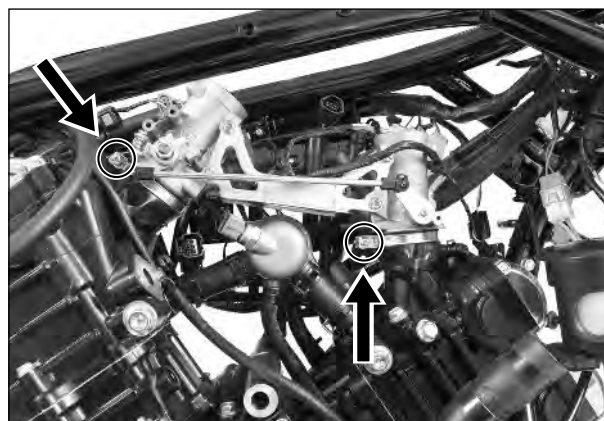
**■ CLUTCH CABLE**

- Disconnect the clutch cable end out of clutch lever.
- Disconnect the clutch cable end out of clutch release arm.

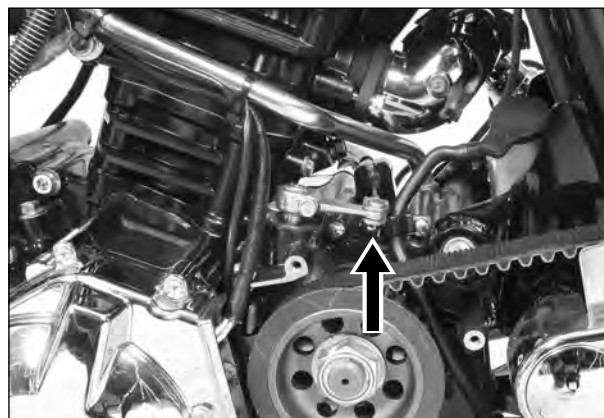

3-5 ENGINE

■ EXHAUST PIPE AND MUFFLER

- With the exhaust pipe bolts (A), exhaust pipe connecting bolts (B) and muffler mounting bolts (C) removed, remove the exhaust pipes and muffler.

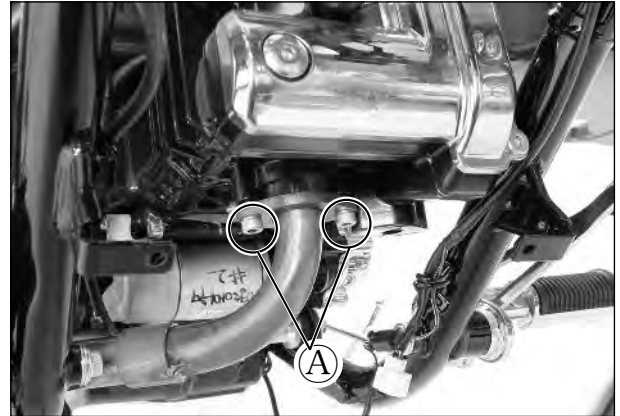

Front Cylinder

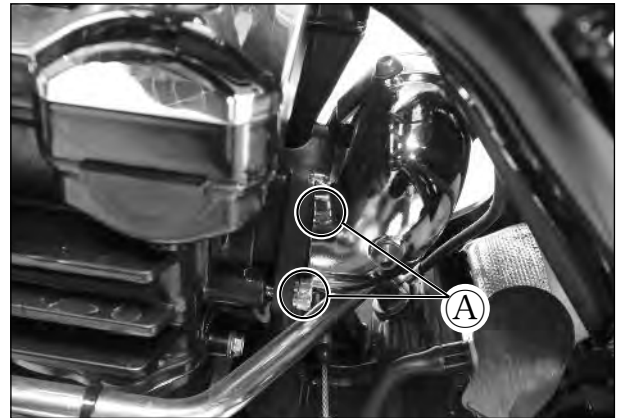

Rear Cylinder

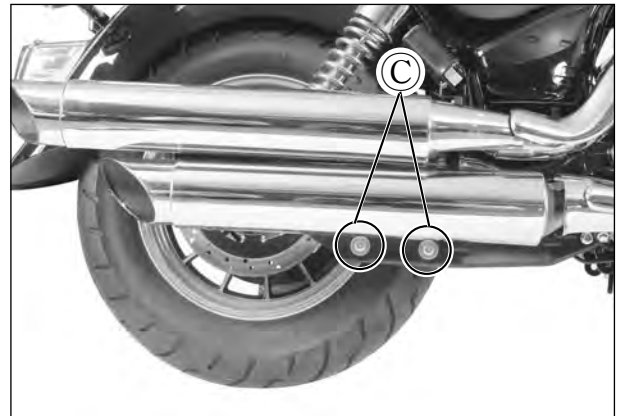
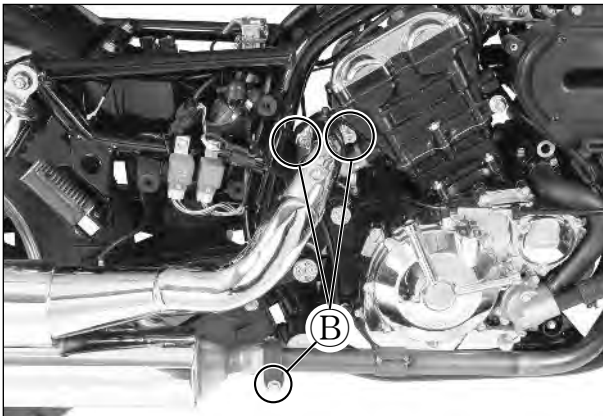

■ ELECTRIC PARTS

- By taking out the spark plug caps, remove the spark plug.



Front Cylinder

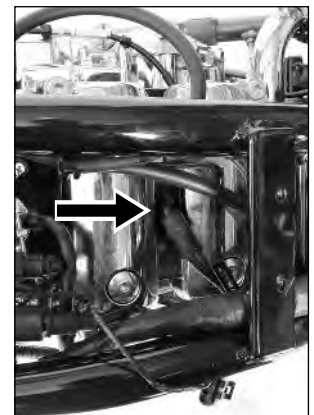

Rear Cylinder

- Remove the starter motor lead wire.

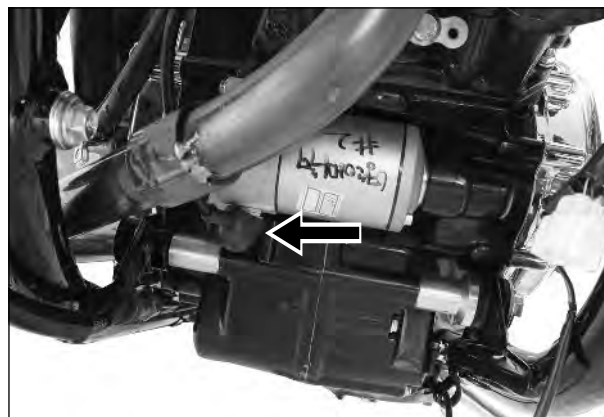

- Remove the engine ground lead wire ①.

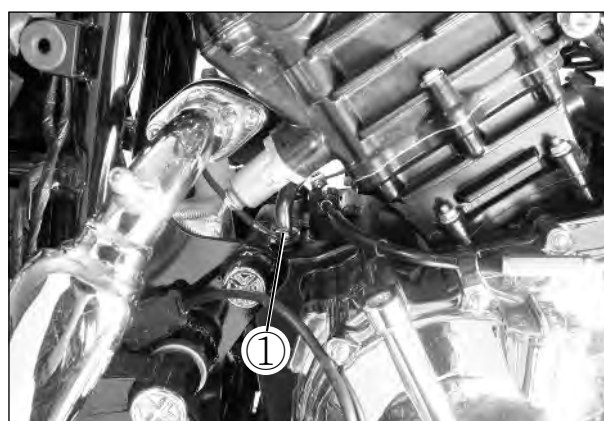

- Disconnect the two magneto coupler ②.
- Disconnect the neutral switch terminal ③.
- Disconnect the side-stand switch lead wire coupler ④.

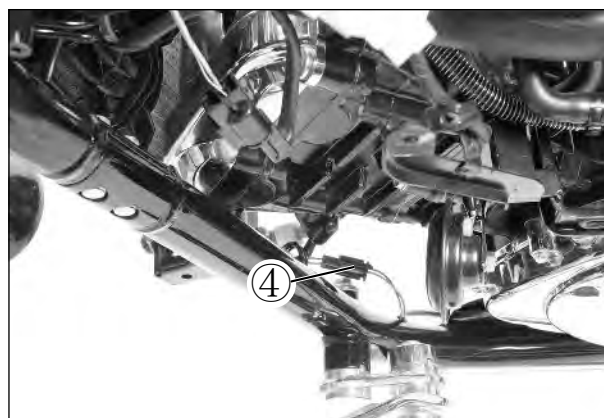
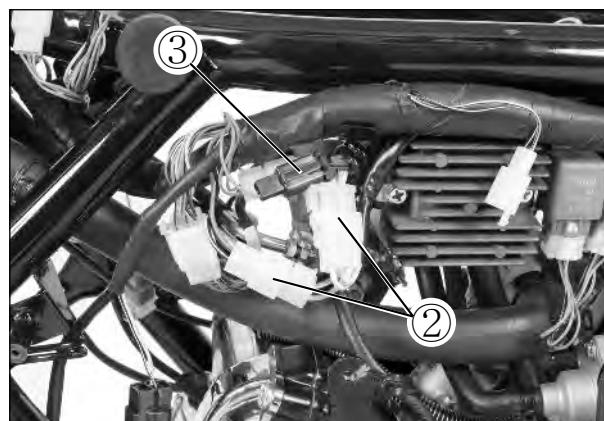

3-7 ENGINE

▣ ENGINE PULLEY

- Remove the engine pulley cover ①.

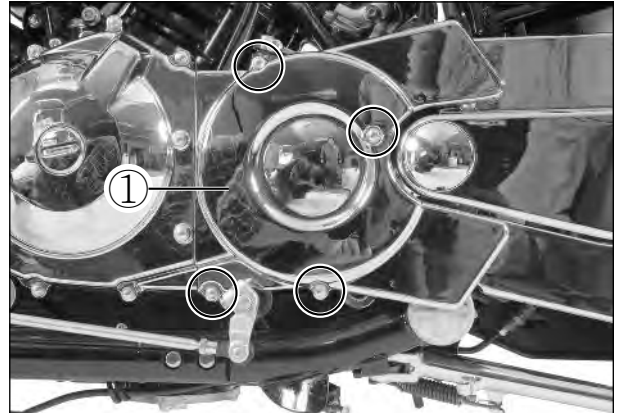

- Disconnect the front crankcase breather hose ② and rear crankcase breather hose ③.

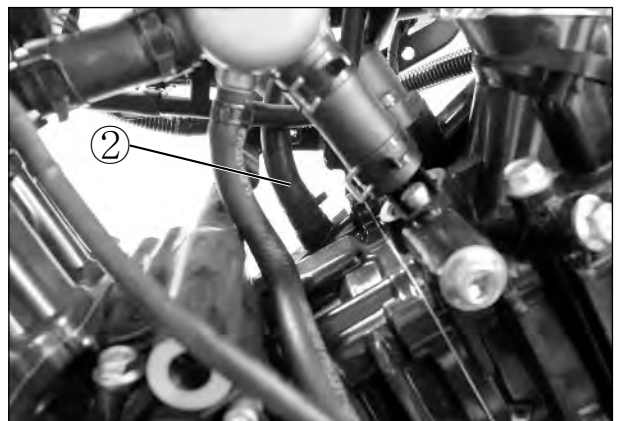

- Remove the gearshift arm ④.
- Flatten the lock washer.
- Remove the engine pulley nut ⑤ and washer.

NOTE

When loosening the engine pulley nut, depress the brake pedal.

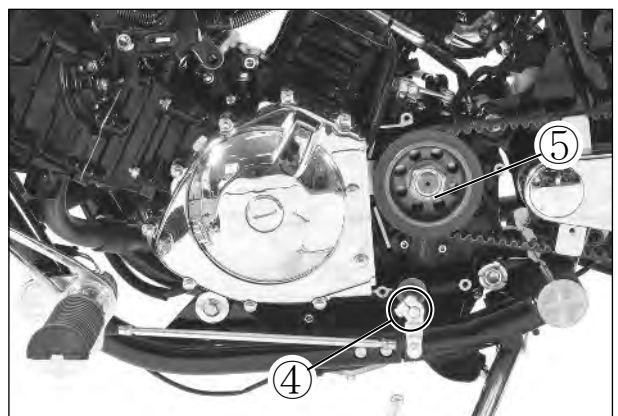

- Remove the engine pulley.

NOTE

If it is difficult to remove the engine pulley, loosen the rear axle bolt, belt adjusters ① · ② to provide additional belt slack. (Refer to page 2-15)

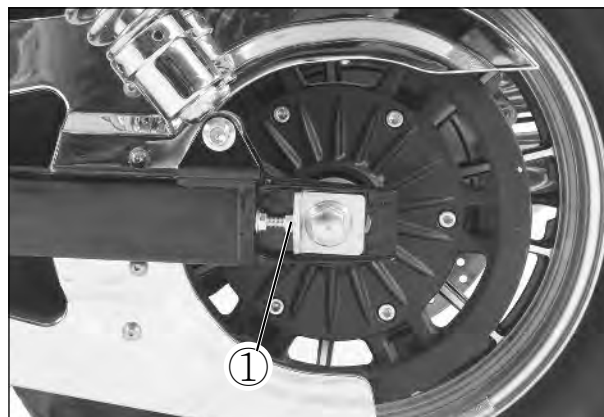

- Remove the frame down tube.
- Support the engine using an engine jack.
- Remove the engine mounting nuts, bolts and engine mounting lock nuts with the special tool.

 **Engine mounting socket wrench (M20)**
: 09940H30010

- Remove the engine from the frame.

⚠ CAUTION

Remove the throttle body when removing or installing the engine necessarily.
When removing the throttle body, loosen the intake pipe mounting bolts at the same time.

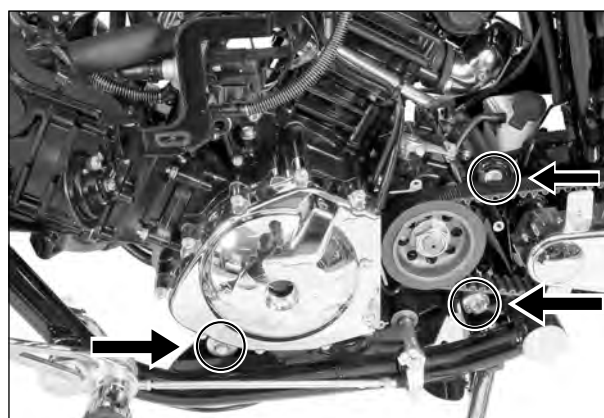
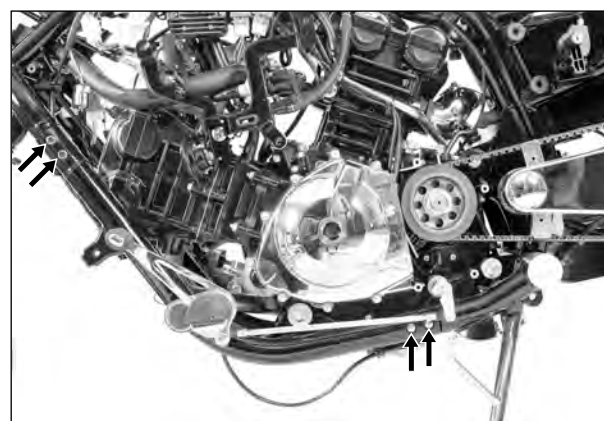

ENGINE REMOUNTING

Reinstall the engine in the reverse order of engine removal.

- Install the engine mounting bolts, nuts and engine mounting lock nuts with the special tool.

 **Engine mounting socket wrench (M20)**
: 09940H30010

- Tighten the engine mounting bolts, nuts and engine mounting lock nuts to the specified torque.

 **Engine mounting bolt ①, ②**
: 15 ~ 30 N · m (1.5 ~ 3.0 kgf · m)

Engine mounting nut ③
: 45 ~ 70 N · m (4.5 ~ 7.0 kgf · m)

Engine mounting lock nut (M20) ④
: 35 ~ 50 N · m (3.5 ~ 5.0 kgf · m)

- Tighten the frame down tube mounting bolts ⑤ to the specified torque.

 **Frame down tube mounting bolt ⑤**
: 22 ~ 35 N · m (2.2 ~ 3.5 kgf · m)

CAUTION

Set the part ① of engine mounting bolt ① align center line by the hand temporarily and install the engine mounting bolt to the specified torque. If otherwise, it is damage to the thread of engine mounting bolt.

NOTE

Set the part ③ of swingarm pivot shaft ③ align center line by the hand temporarily and install the swingarm pivot shaft to the specified torque.

 **Swingarm pivot shaft ③**
: 15 ~ 30 N · m (1.5 ~ 3.0 kgf · m)

Swingarm pivot nut ④
: 50 ~ 70 N · m (5.0 ~ 7.0 kgf · m)

Swingarm mounting lock nut (M26) ⑤
: 70 ~ 80 N · m (7.0 ~ 8.0 kgf · m)

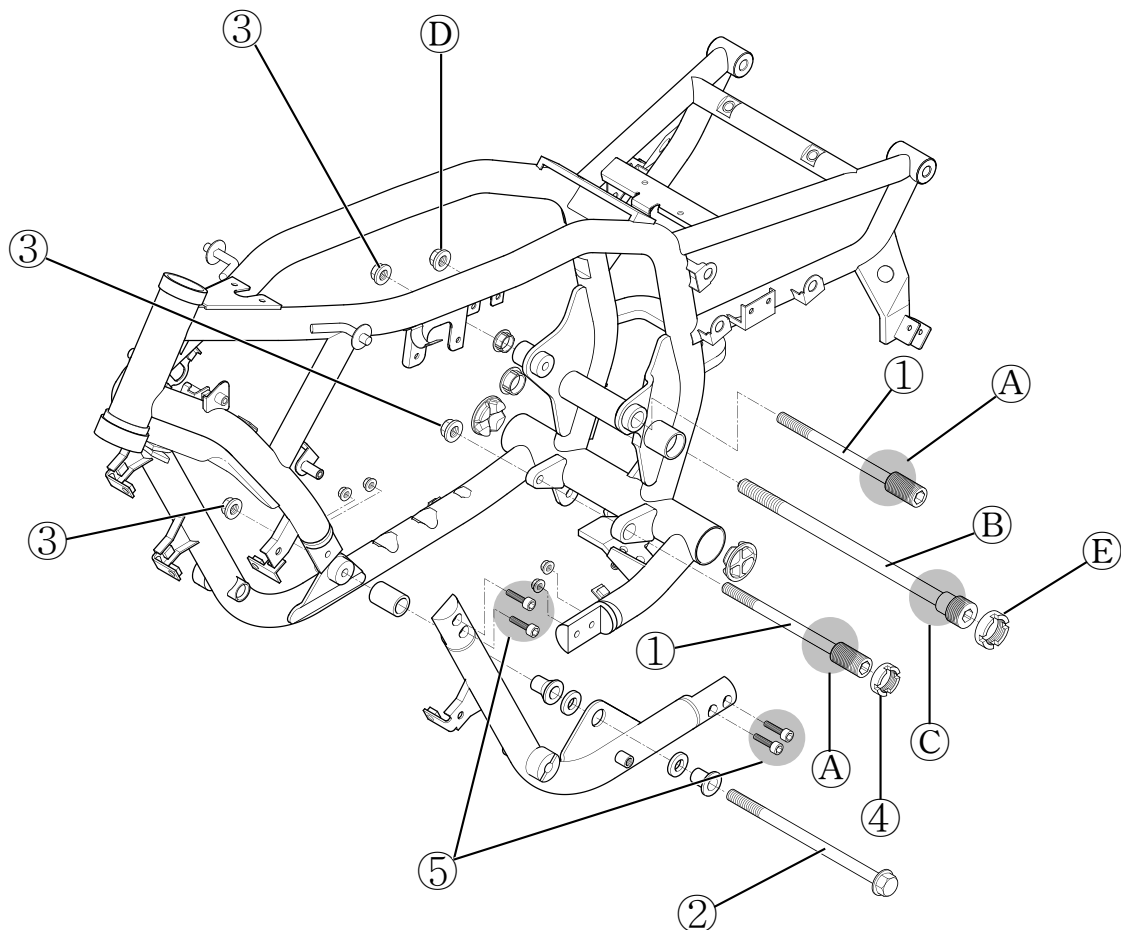

■ ENGINE PULLEY

- Loosen the rear axle ① and belt adjusters ②, left and right.
- Install the engine pulley.

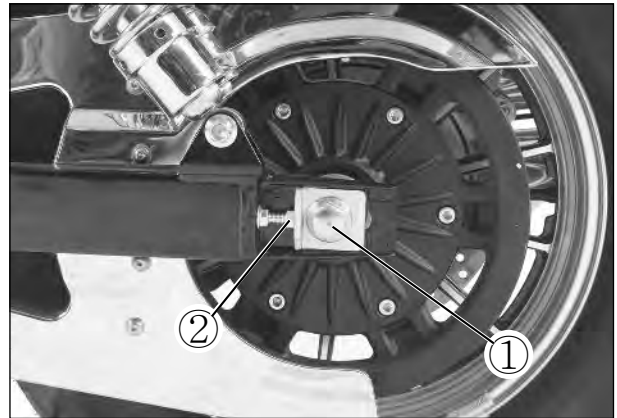

- Tighten the engine pulley nut ③ to the specified torque.



Engine pulley nut

: 130 ~ 160 N · m (13.0 ~ 16.0 kgf · m)

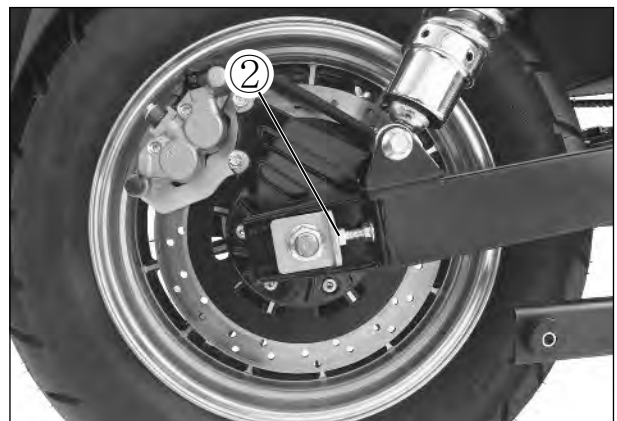

NOTE

When tightening the engine pulley nut, depress the rear brake pedal.

- Bend the lock washer securely.
- Install the gearshift arm and adjust the gearshift lever height. (Refer to page 2-10)
- Install the breather hose and engine pulley cover.
- Connect each electric parts and its couplers. (See pages 9-30 through 36)
- Connect the all sensor and its couplers. (Refer to chapter 4 and 5)
- Install the exhaust pipes and mufflers.
- Install the throttle body and air cleaner. (Refer to page 5-8)
- Install the radiator and radiator cover. (Refer to page 6-4)
- After remounting the engine, the following adjustments are necessary.
 - * Engine idling speed inspect Refer to page 2-9
 - * Throttle cable play Refer to page 2-9
 - * Clutch cable play Refer to page 2-10
 - * Drive belt Refer to page 2-15
 - * Gearshift lever height Refer to page 2-10
 - * Engine oil level Refer to page 2-13
 - * Engine coolant Refer to page 2-24

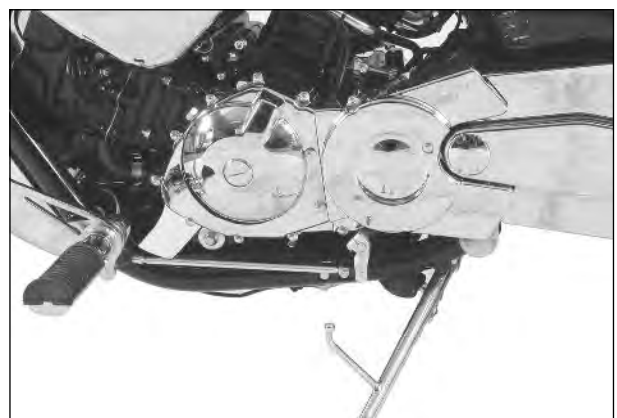
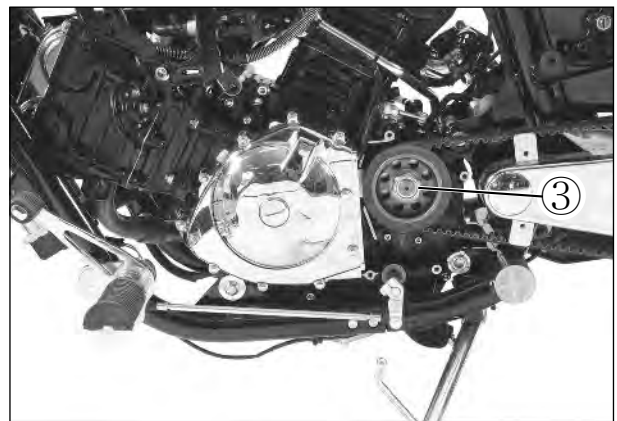

ENGINE DISASSEMBLY

 **CAUTION**

Identify the position of each removed part.
Organize the parts in their respective groups
so that they can be reinstalled in their original positions.



STARTER MOTOR

- Remove the starter motor.



- Remove the gear position switch.
- Remove the contacts ① and springs ②.

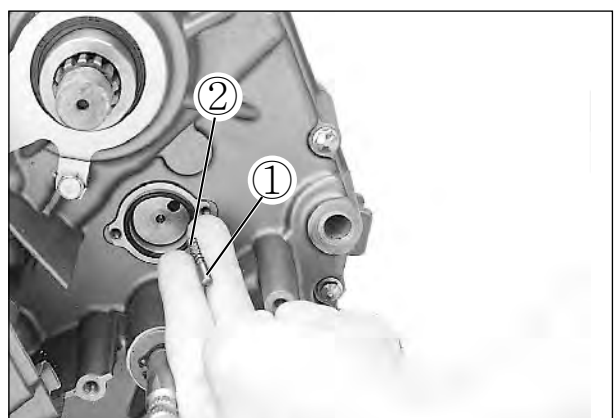

THERMOSTAT

- Remove the thermostat case ① along with the hose ②.

NOTE

*Thermostat inspection and servicing
: Refer to page 6-9*

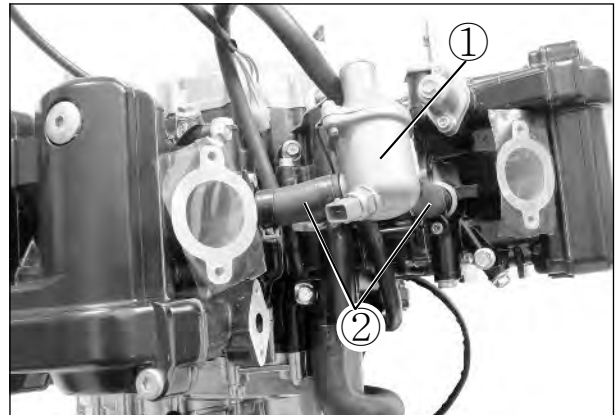

CYLINDER HEAD COVER

- Remove the cylinder head cover.

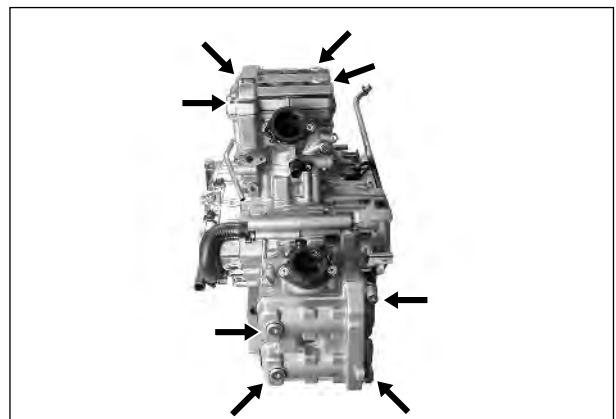

- To set the piston at TDC (Top Dead Center).

⚠ CAUTION

Align the index mark on the magneto rotor with the index mark on the magneto cover as turn the crankshaft counter-clockwise.
To set piston at TDC (Top Dead Center) of the compression stroke as align the “ | F ” mark for front cylinder and the “ | R ” mark for rear cylinder.



- Remove the cam chain tensioner adjuster ①, ②.

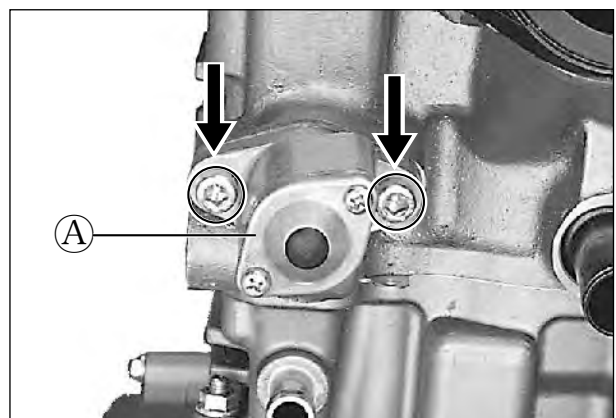

Front Cylinder

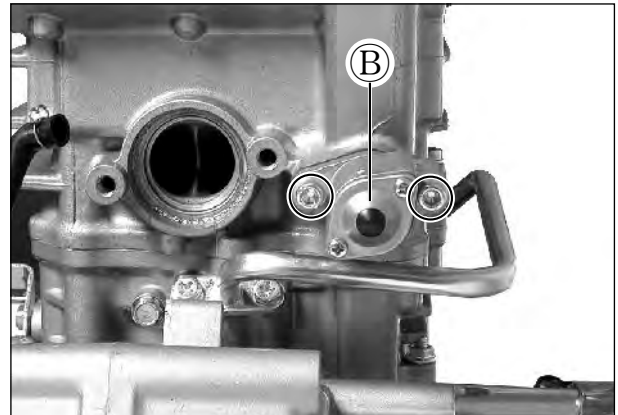

Rear Cylinder

- With the three bolts removed, remove the cam chain guide NO.2 ①.

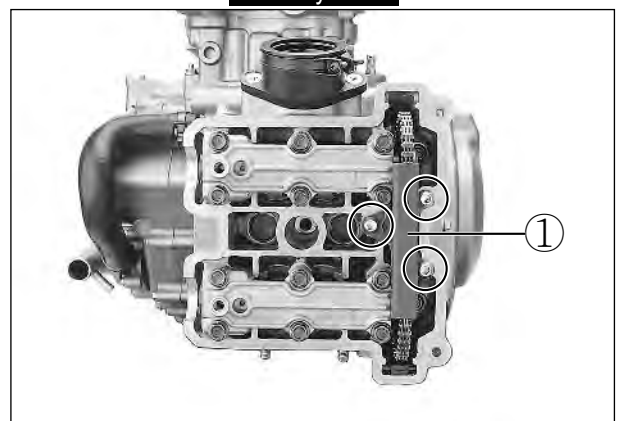

- Remove the camshaft housing ②.

NOTE

Mark an identification of assembly location on each removed parts so that each will be restored to the original position during reassembly.

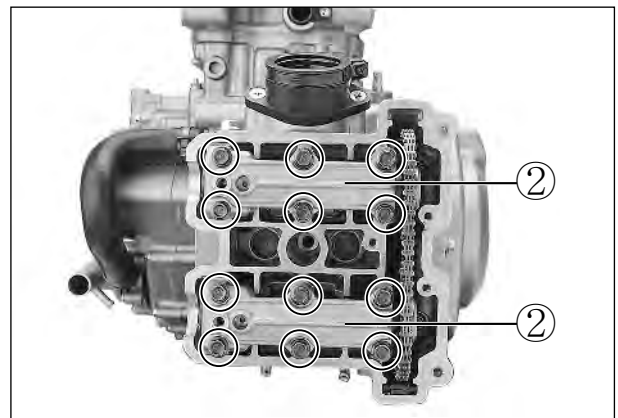

- Remove the camshaft (IN. · EX.) ③.

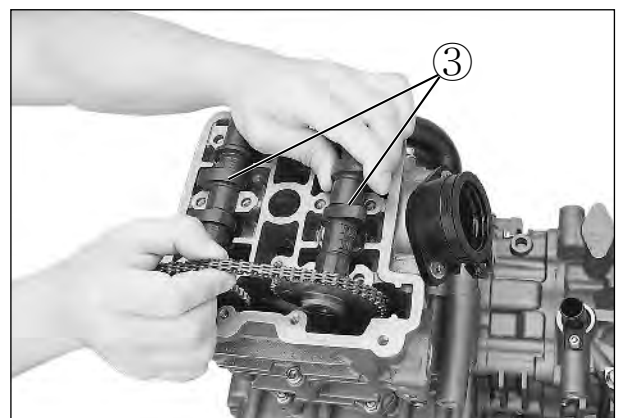

- Loosen the cylinder head base bolt.

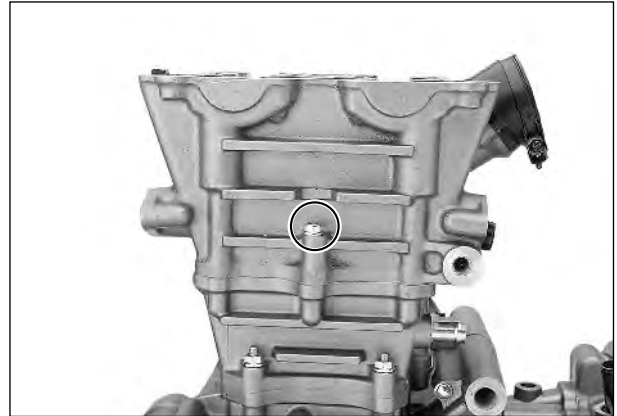

- Loosen the six cylinder head bolts.

NOTE

When loosening the cylinder head bolts, loosen each bolt little by little diagonally.

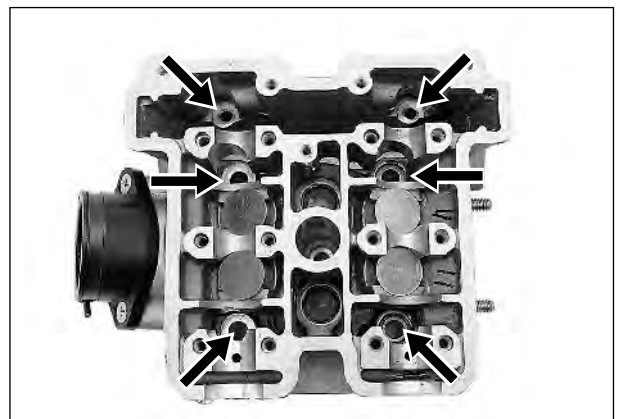

- Remove the chain guide NO.1 and cylinder head.



- Remove the tappet and the shim.

CAUTION

Draw out the tappet and shim with the strong magnet not to be scratched.



 **CAUTION**

The tappet and shim should be lined so that each will be restored to the original position during reassembly.

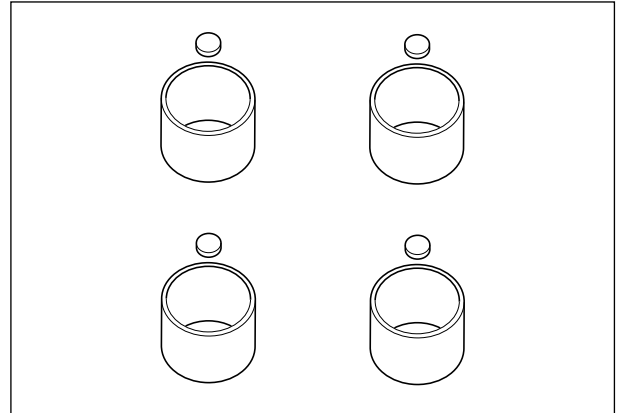

- Compress the valve spring by using the special tool.



Valve spring compressor

: 09916-14510

Valve spring compressor attachment

: 09916-14520



- Take out the valve cotter from the valve stem.
- Remove the valve spring retainer.
- Pull out valve from the other side.

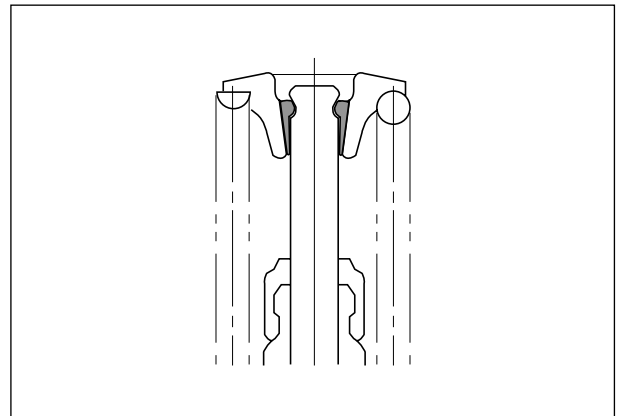

- Remove the two cylinder base nuts and cylinder.

 **CAUTION**

If tapping with the plastic hammer is necessary, pay attention to break the fins.



- Remove the rear cylinder head and cylinder with the same manner of the front cylinder head and cylinder removal.

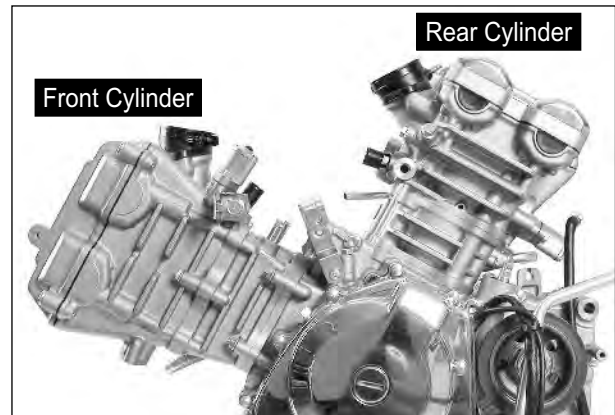

PISTON

- Place a clean rag over the cylinder base to prevent piston pin circlips from dropping into crankcase. Remove the piston pin circlips with long-nose pliers.

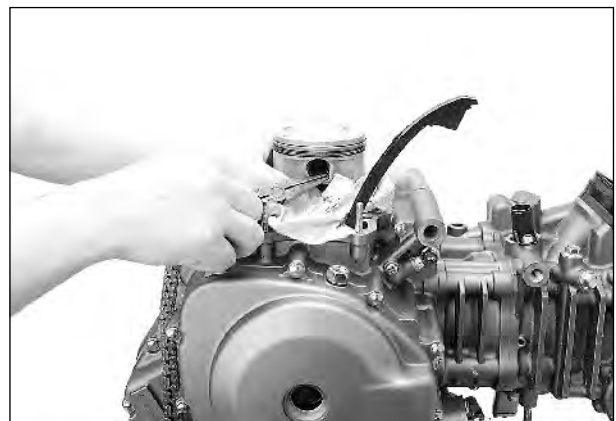

- Remove the piston pin by using the special tool.

 Piston pin puller : 09910-34510

NOTE

Make an identification on each piston head to confirm the cylinder.



MAGNETO COVER

- Remove the magneto cover.

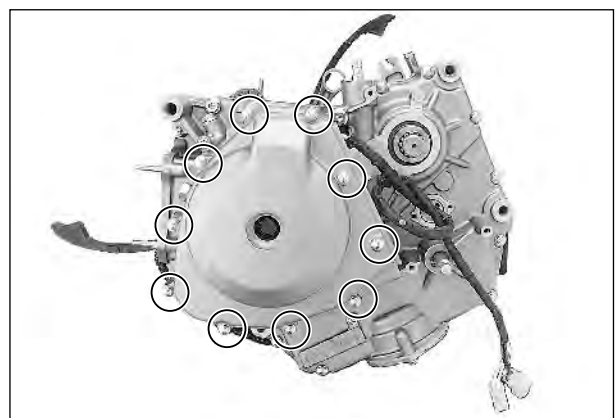

3-17 ENGINE

- Remove the starter idle shaft ①, starter idle gear ②.

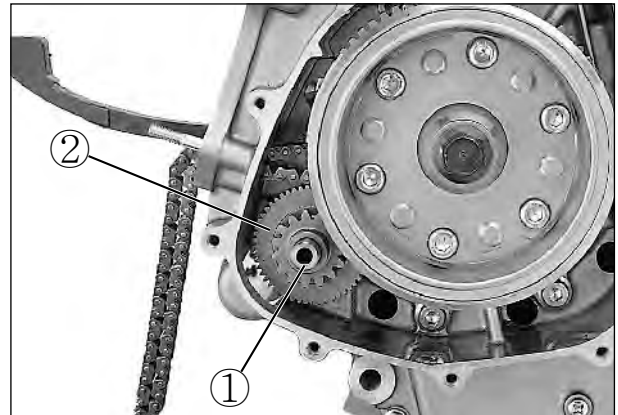

MAGNETO ROTOR

- With the magneto rotor held immovable using the special tool, loosen the rotor nut.

 **Conrod holder : 09910-20115**

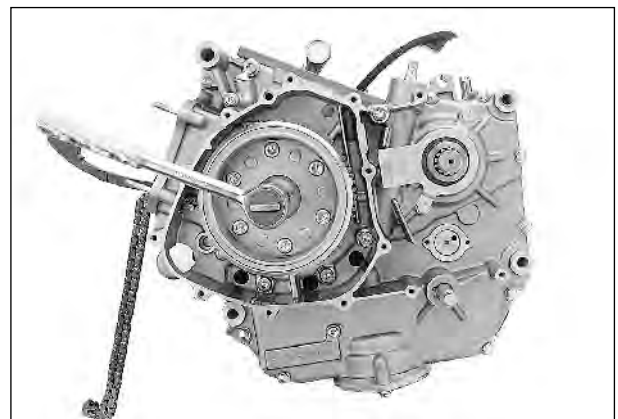

- Remove the magneto rotor by using the special tool.

 **Rotor remover : 09930-30165**



- Remove the key ③.
- Remove the starter driven gear ④.
- Remove the cam chain ⑤.

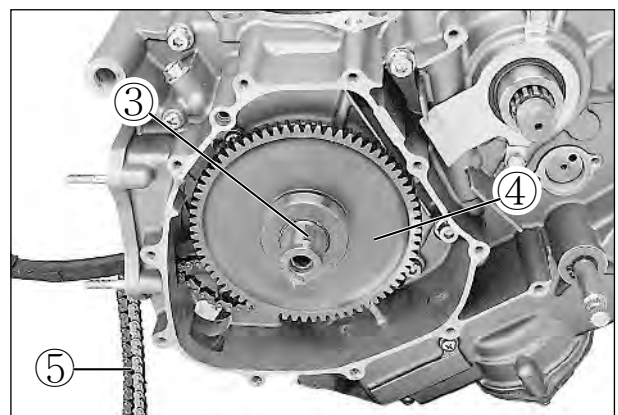

- Remove the cam chain tensioner ①.



CLUTCH COVER

- Remove the clutch release arm ②.

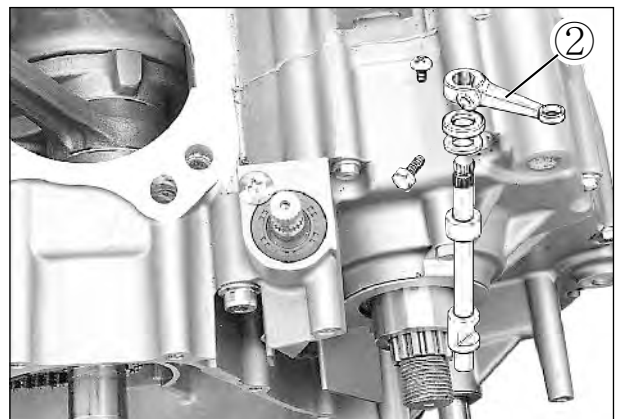

- Remove the clutch cover bolts.
- Remove the clutch cover ③.

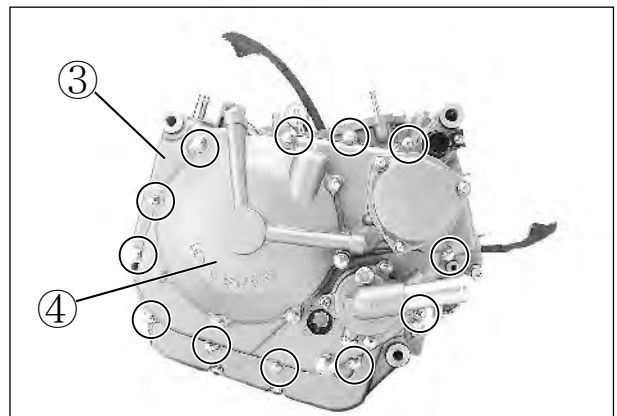

NOTE

When remove or inspect the clutch drive and driven plate, remove only the clutch pressure cover ④.



CLUTCH

- With the primary drive gear held immovable using the special tool, remove the clutch spring mounting bolts diagonally.

 **Conrod holder : 09910-20115**

- Remove the disk pressure ①.



- Remove the clutch drive plates NO. 1 and driven plates.
- Remove the spring washer and spring washer seat.
- Remove the clutch drive plate NO. 2.



- Flatten the lock washer ②.

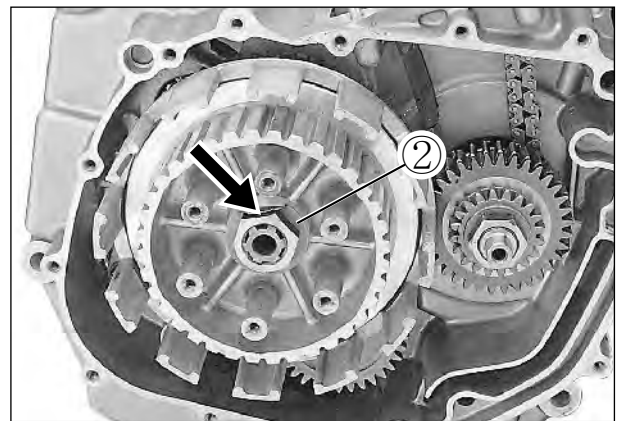

- With the clutch sleeve hub held immovable using special tool, remove the clutch sleeve hub nut.

 **Clutch sleeve hub holder : 09920-53710**

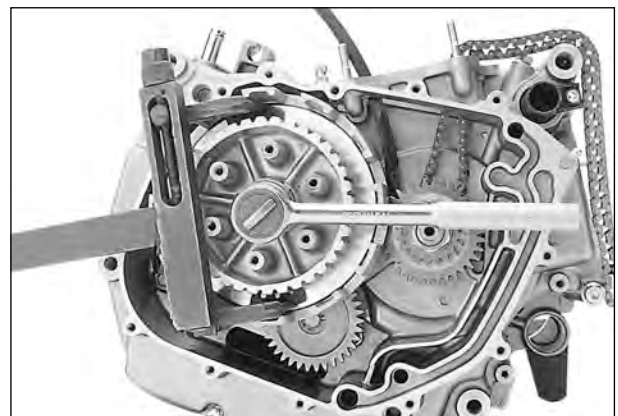

- Remove the clutch sleeve hub ① and primary driven gear assembly ② .

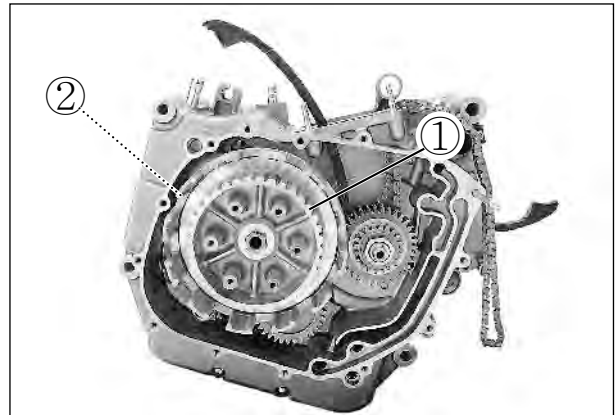

PRIMARY DRIVE GEAR

- With the crankshaft held immovable using special tool, remove the primary drive gear nut ③.
- Remove the water pump drive gear ④ and primary drive gear ⑤.

 **Conrod holder : 09910-20115**

CAUTION

This nut has left-hand thread. If turning it counter-clockwise (), it may cause damage.

Pay attention at the primary drive gear nut with a washer, and water pump drive gear with a washer.

- Remove the cam chain ⑥.
- Remove the cam chain tensioner ⑦.

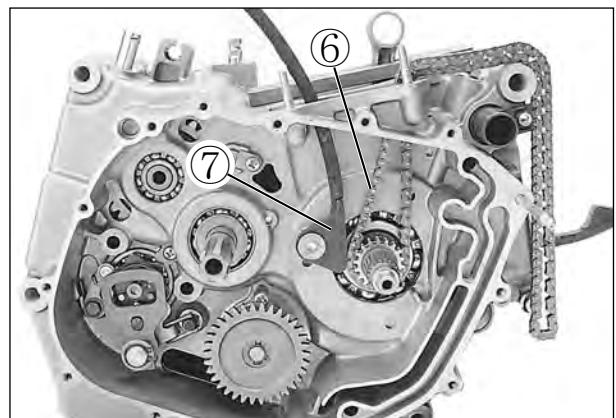
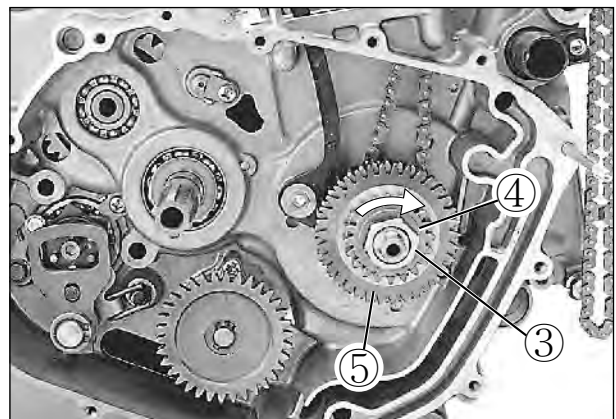

OIL PUMP

- Remove the circlip ⑧ and oil pump driven gear ⑨.

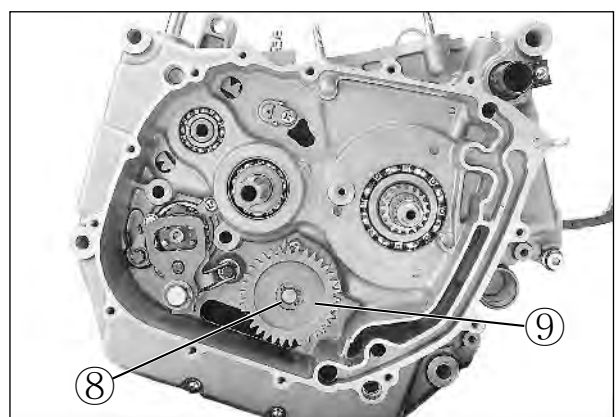

3-21 ENGINE

- Remove the pin ① and shim.
- With the three screws loosened, remove the oil pump ②.

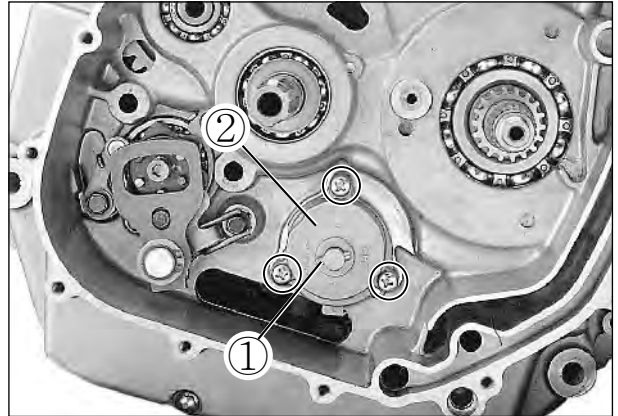

GEARSHIFT SHAFT

- Draw out the gearshift shaft ③.

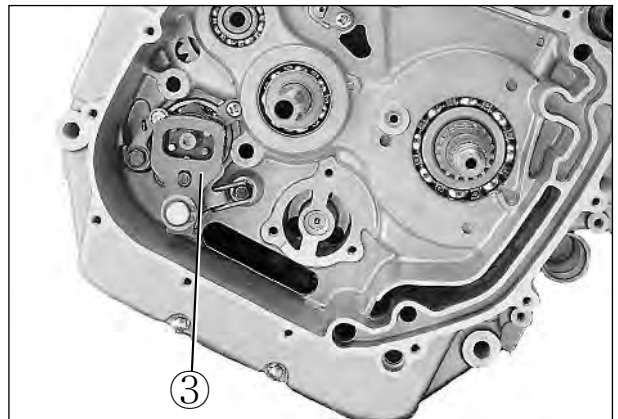

- Remove the gearshift cam stopper ④.
- Loosen the gearshift cam plate bolt ⑤.
- Remove the gearshift cam stopper plate.

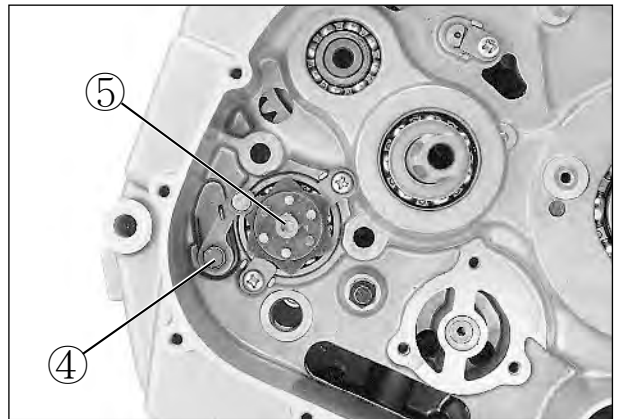

- Remove the crankcase securing bolts, right and left.

NOTE

Loosen the crankcase bolts diagonally and smaller sizes first.

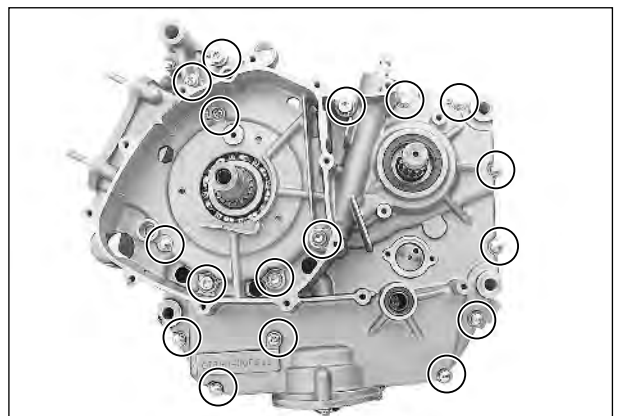



- Remove the mission oil pipe mounting bolt.

- Separate the crankcase into 2 parts, right and left, with a special tool.

 **Crankcase separator : 09920-13120**

CAUTION

When separating the crankcase, necessarily, remove it after installed the special tool (Crankcase separator) on the side of clutch. In case separate oppositely, the gearshift cam stopper will be damaged in the side of magneto.

NOTE

Fit the crankcase separator, so that the tool arms parallel the side of the crankcase.

- Remove the gearshift fork shaft ① and gearshift fork ②.
- Remove the gearshift cam ③.
- Remove the driveshaft assembly ④, countershaft assembly ⑤.

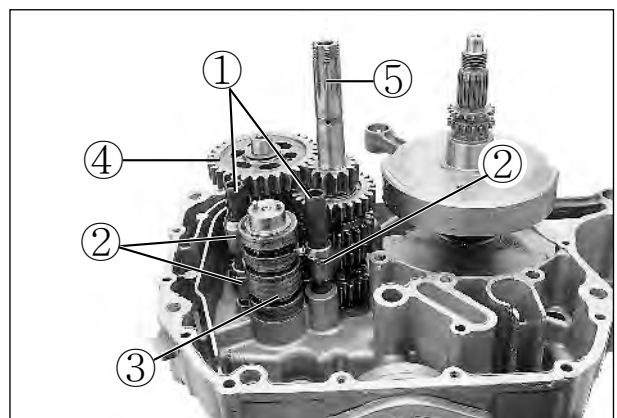
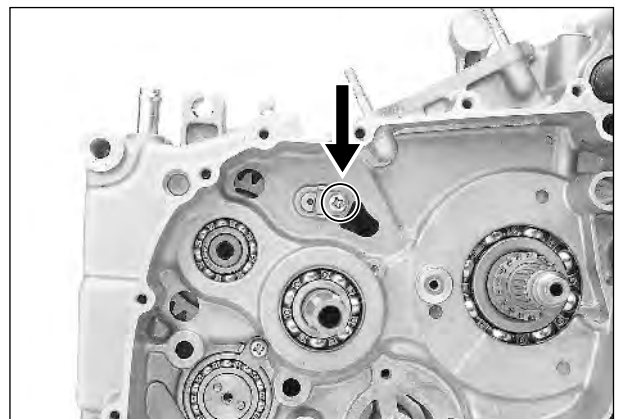

- Remove the crankshaft by using the special tool.

 Crankcase separator : 09920-13120

ENGINE COMPONENT INSPECTION AND SERVICE

CAUTION

Be sure to identify each removed part as to its location, and lay the parts out in groups designated as “Front cylinder”, “Rear cylinder”, “Exhaust”, “Intake”, so that each will be restored to the original location during assembly.

● CYLINDER HEAD DISTORTION

Decarbonate in combustion chamber.

Check the gasket surface of the cylinder head for distortion with a straightedge and thickness gauge, taking a clearance reading at several places as indicated. If the largest reading at any position of the straightedge exceeds the limit, replace the cylinder head.

Cylinder head distortion	Service limit
	0.05 mm (0.002 in)

 Thickness gauge : 09900-20806

● VALVE FACE WEAR

Visually inspect each valve face for wear. Replace any valve with an abnormally worn face. The thickness of the valve face decreases as the face wears. Measure the valve head thickness Ⓣ . If it is out of specification, replace the valve with a new one.

Valve head thickness Ⓣ	Service limit
	0.5 mm (0.02 in)

 Vernier calipers : 09900-20101

● VALVE STEM RUNOUT

Check the valve stem for abnormal wear or bend. Place the valve on V-blocks and measure runout. If the service limit is exceeded or abnormal condition exists, replace the valve.

Valve stem runout	Service limit
	0.05 mm (0.002 in)

 Dial gauge : 09900-20606

Magnetic stand : 09900-20701

V-block : 09900-21304

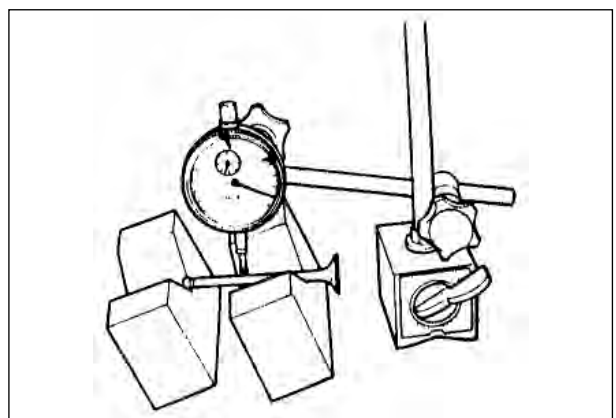
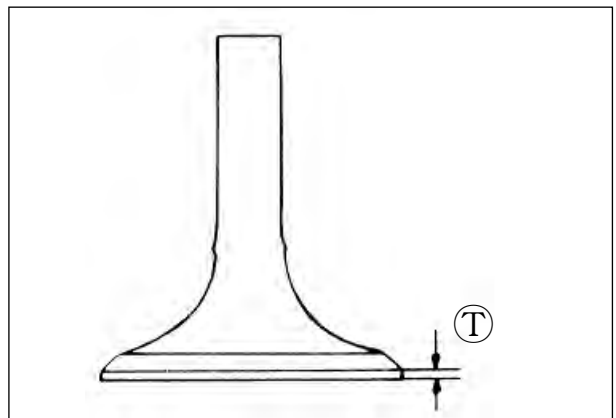
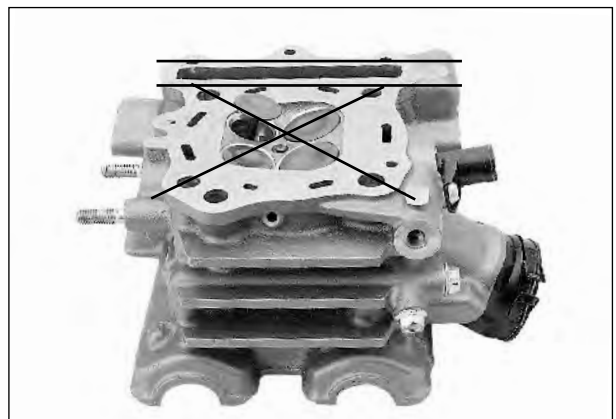

● CAMSHAFT

The camshaft should be checked for runout and also for wear of cams and journals if the engine has been noted to produce abnormal noise or vibration or a lack of output power. Any of these abnormality could be caused by a worn camshaft.

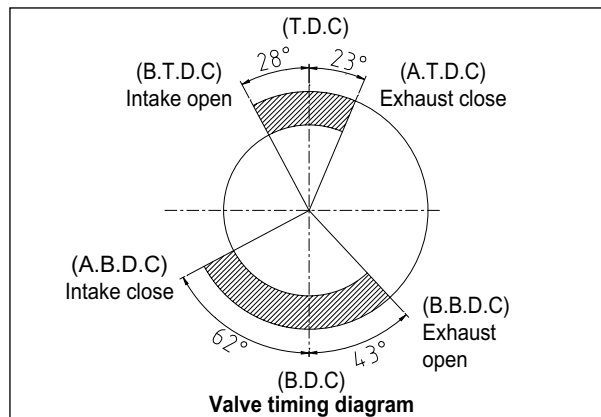

■ CAMSHAFT WEAR

Worn-down cams are often the cause of mistimed valve operation resulting in reduced output power.

The limit of cam wear is specified for both intake and exhaust cams in terms of cam height H , which is to be measured with a micrometer. Replace camshafts if found it worn down to the limit.

Cam height H	Service limit
Intake cam	34.98 mm (1.377 in)
Exhaust cam	33.08 mm (1.302 in)

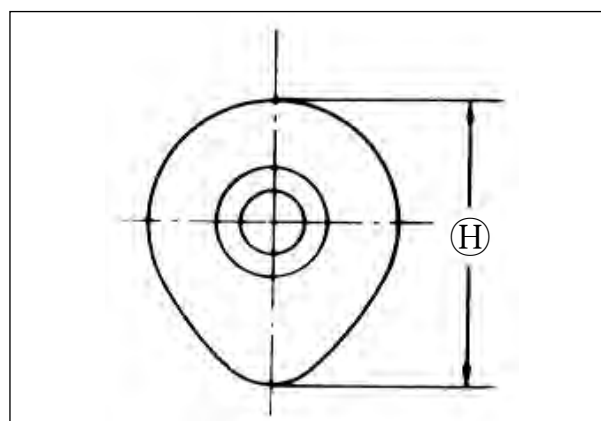

 **Micrometer(25~50 mm) : 09900-20202**

■ CAMSHAFT JOURNAL WEAR

Determine whether or not each journal is worn down to the limit by measuring the oil clearance with the camshaft installed in place.

- Use the plastigauge to read the clearance at the widest portion, which is specified as follows :

Camshaft journal	Service limit
oil clearance (IN & EX)	0.15 mm (0.006 in)

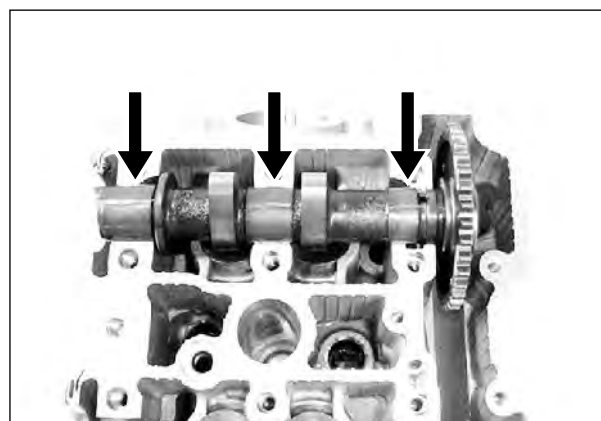

● TAPPET & SHIM WEAR

When measuring the valve clearance, the clearance should be within the standard range.

Valve clearance	Standard (When cold)
Intake valve	0.1 ~ 0.2 mm (0.004 ~ 0.008 in)
Exhaust valve	0.28 ~ 0.32 mm (0.011 ~ 0.013 in)

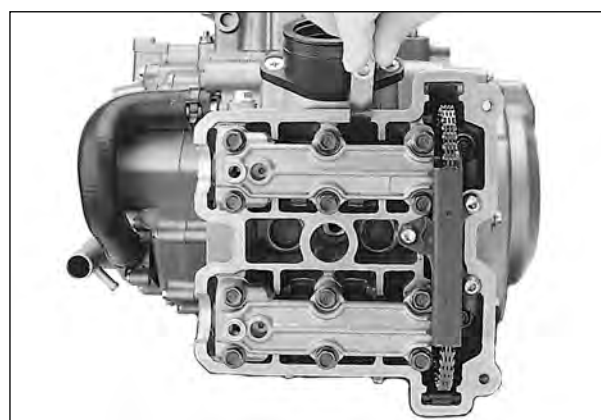

3-25 ENGINE

- Inspect the tappet for wear and scratch.
If modification or scratch is present, replace the tappet.
- When you checked the valve clearance, if the valve clearance is wide please replace the present shim into thick one, if the valve clearance is narrow please replace the present shim into thin shim.
(Refer to page 9-39·40)

■ SHIM KIND

There are 41 kinds of shim which thickness is increased by each 0.025 mm from 1.20 mm to 2.20 mm.

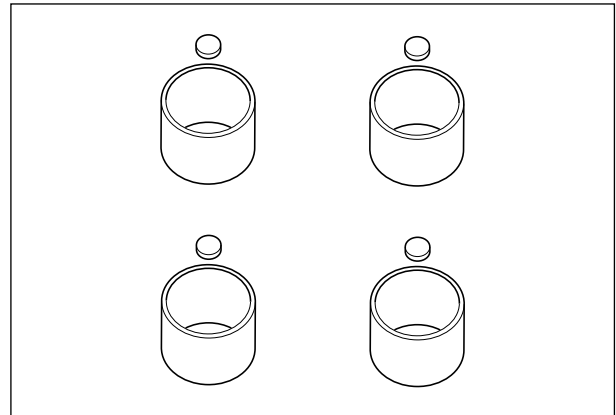

● VALVE HEAD RADIAL RUNOUT

Place a dial gauge as shown and measure valve head radial runout.

If the service limit is exceeded, replace the valve.

Valve head radial runout	Service limit
	0.03 mm (0.0012 in)

-  Dial gauge : 09900-20606
- Magnetic stand : 09900-20701
- V-block : 09900-21304

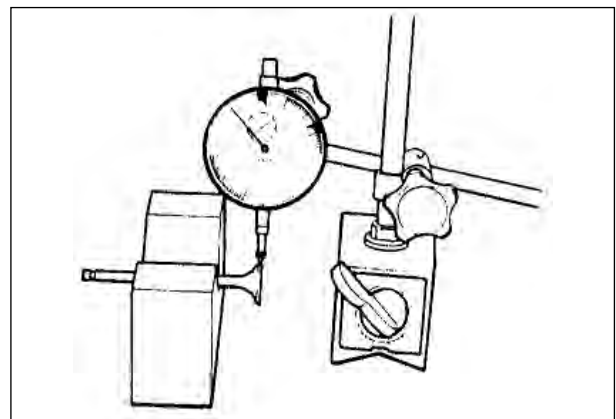

● VALVE GUIDE-VALVE STEM CLEARANCE

Measure the clearance in the valve guide-valve stem, by rigging up the dial gauge as shown. If the clearance is measured exceeds the limit specified below, then determine whether the valve or the guide should be replaced to reduce the clearance to within the standard range :

Valve guide-valve stem clearance	Standard
IN.	0.020~0.047 mm (0.0008~0.0019 in)
EX.	0.030~0.057 mm (0.0012~0.0022 in)

-  Dial gauge : 09900-20606
- Magnetic stand : 09900-20701

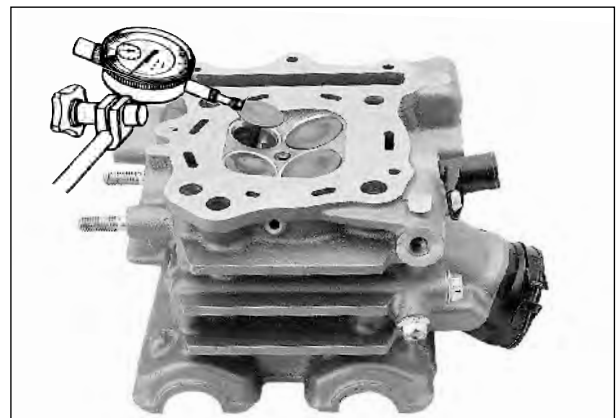

● VALVE STEM DIAMETER

Measure the valve stem outside diameter.

If the diameter measured exceeds the standard, replace the valve.

Valve stem diameter	Standard
IN.	4.465~4.480 mm (0.1758~0.1764 in)
EX.	4.455~4.470 mm (0.1754~0.1760 in)

-  Micrometer(0~25 mm) : 09900-20201

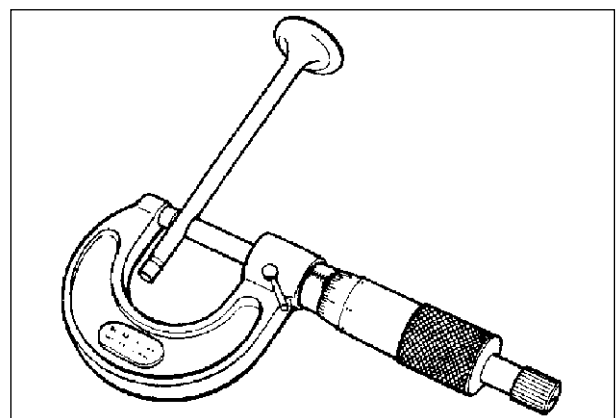

⊙ VALVE SPRING

The force of the coil spring keeps the valve seat tight. A weakened spring results in reduced engine power output and often accounts for the chattering noise coming from the valve mechanism.

Check the valve springs for proper strength by measuring their free length and also by the force required to compress them. If the spring length is less than the service limit or if the force required to compress the spring does not fall within the specified range, replace both the inner and outer springs as a set.

Valve spring free length	Service limit
Inner	36.8 mm (1.45 in)
Outer	39.8 mm (1.57 in)

 **Venier calipers : 09900-20101**

Valve spring tension	Standard
Inner	4.2 ~ 4.8 kgf (9.3 ~ 10.6 lbs) at length 29.9 mm (1.18 in)
Outer	17.0 ~ 19.6 kgf (37.5 ~ 43.2 lbs) at length 33.4 mm (1.32 in)

⊙ CYLINDER DISTORTION

Check the gasketed surface of the cylinder for distortion with a straightedge and thickness gauge, taking a clearance reading at several places as indicated. If the largest reading at any position of the straightedge exceeds the limit, replace the cylinder.

Cylinder distortion	Service limit
	0.05 mm (0.002 in)

 **Thickness gauge : 09900-20806**

⊙ CYLINDER BORE

Measure the cylinder bore diameter at six place. If any one of the measurements exceeds the limit, overhaul the cylinder and replace the piston with an oversize, or replace the cylinder.

	Standard	Service limit
Cylinder bore	81.500~81.515 mm	81.575 mm
	(3.2087~3.2093 in)	(3.2116 in)

 **Cylinder gauge set : 09900-20508**

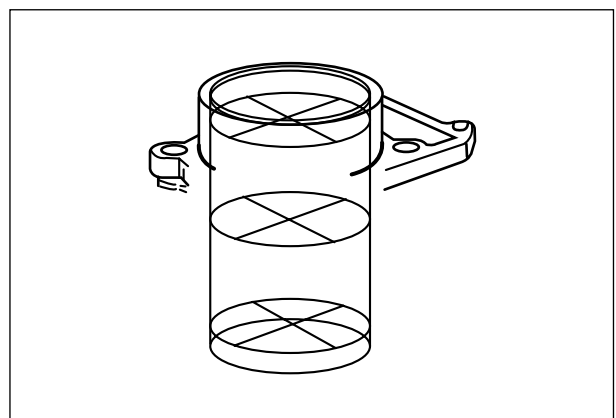
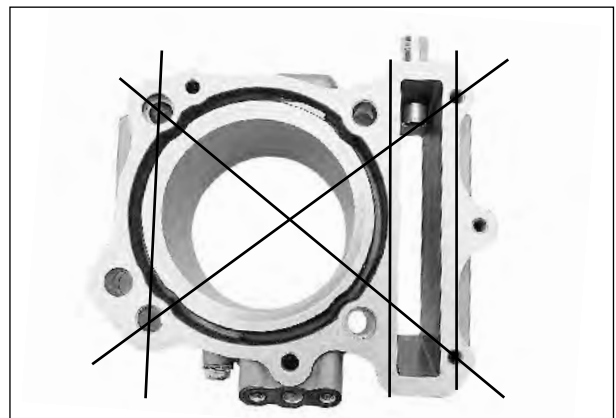
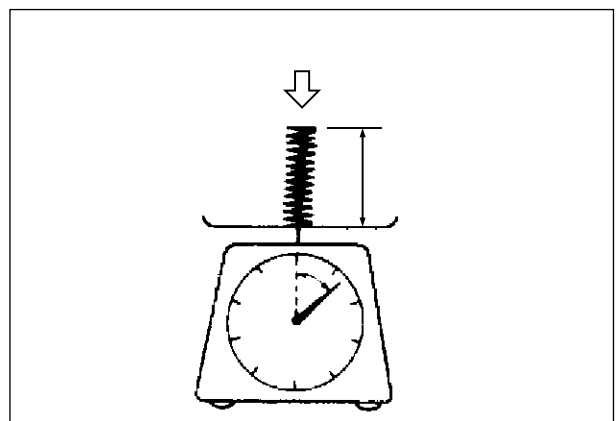
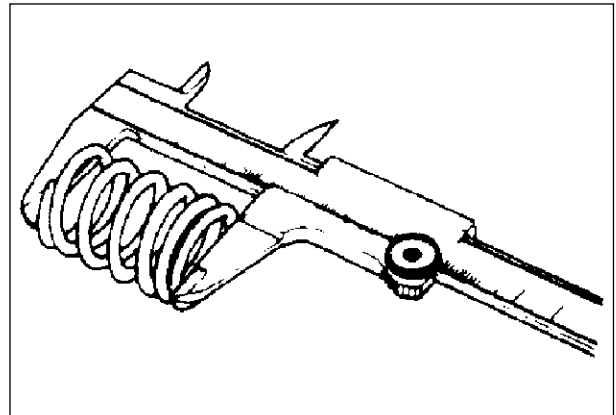

● CAM CHAIN TENSIONER ADJUSTER

Check that the push rod slides smoothly with the lock shaft handle ① clockwise.

If it does not slide smoothly, replace the cam chain tensioner adjuster with a new one.

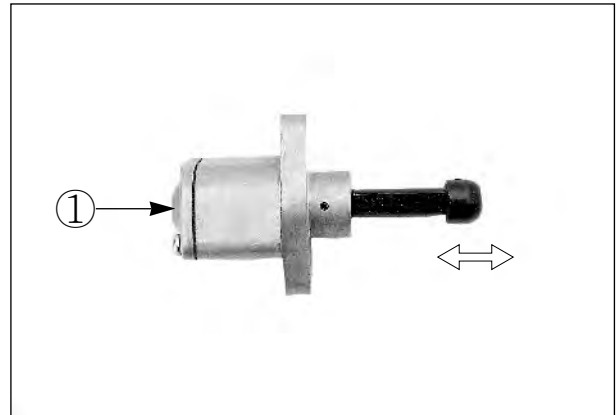

● CAM CHAIN TENSIONER

Check the contacting surface of the cam chain tensioner.

If it is worn or damaged, replace it with a new one.

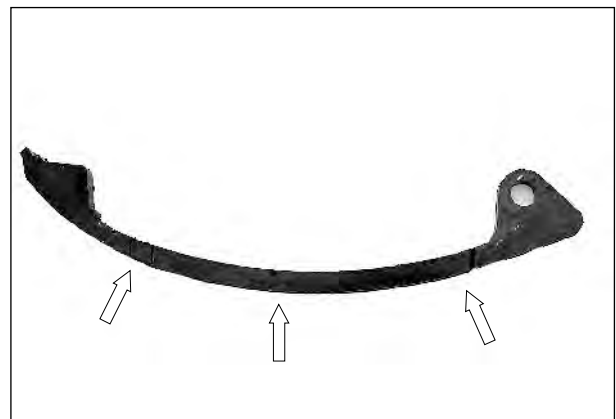

● CAM CHAIN AND CAM CHAIN GUIDE

Check the cam chain for wear, damage and kinked or binding links. If any defects are found, replace it with a new one.

Check the cam chain guide for wear and damage. If it is found to be damaged, replace it with a new one.

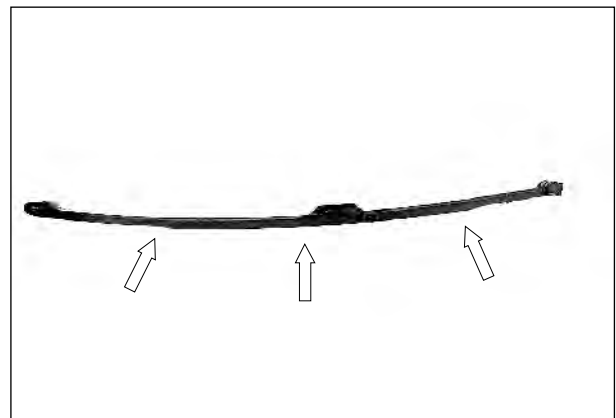



● PISTON DIAMETER INSPECTION

Measure the outside diameter of piston in the direction perpendicular to the piston pin axis at the height from the skirt as shown in the illustration using a micrometer.

If the measurement is found less than the service limit, replace the piston.

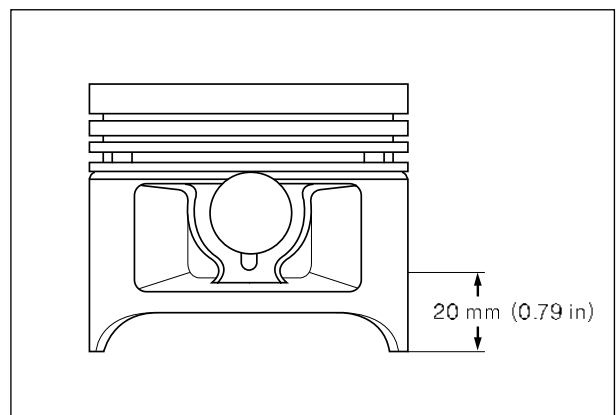
Piston diameter	Service limit
	81.380 mm (3.2039 in)
Piston oversize	0.5, 1.0 mm (0.02, 0.04 in)



 **Micrometer(75~100 mm) : 09900-20204**

⦿ PISTON-TO-CYLINDER CLEARANCE

To determine the piston-to-cylinder clearance, calculate the difference between the cylinder bore and outside diameter of the piston.

	Standard	Service limit
Piston-to-cylinder clearance	0.045~0.075 mm (0.0018~0.0030 in)	0.120 mm (0.0047 in)

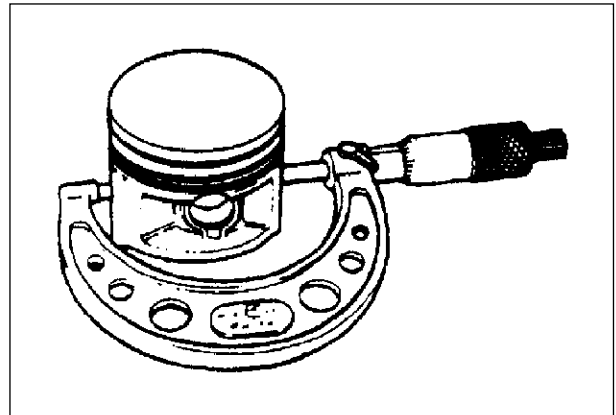

⦿ PISTON PIN HOLE BORE

Using a dial calipers, measure the piston pin hole bore both the vertical and horizontal directions. If the measurement exceeds the service limit, replace the piston.

	Service limit
Piston pin hole bore	20.030 mm (0.7886 in)

 Dial calipers : 09900-20605

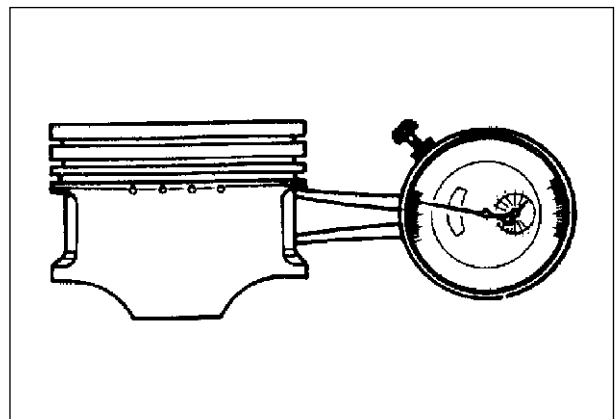

⦿ PISTON PIN DIAMETER INSPECTION

Using a micrometer, measure the piston pin outside diameter at three position, both the ends and the center. If any of the measurements is found less than the service limit, replace the pin.

	Service limit
Piston pin diameter	19.980 mm (0.7866 in)

 Micrometer(0~25 mm) : 09900-20201

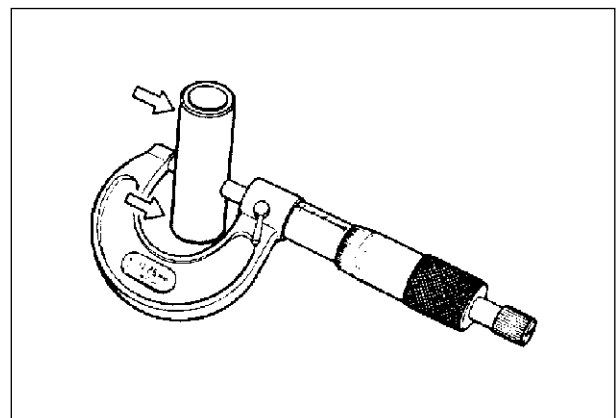

⦿ PISTON RING FREE END GAP INSPECTION

Before installing piston rings, measure the free end gap of each ring using a vernier calipers. If the gap is less than the service limit, replace the ring.

Piston ring free end gap	Standard
1st	Approx. 9.9 mm (0.390 in)
2nd	Approx. 10.5 mm (0.413 in)

Piston ring free end gap	Service limit
1st	7.9 mm (0.311 in)
2nd	8.4 mm (0.330 in)

 Vernier calipers : 09900-20101

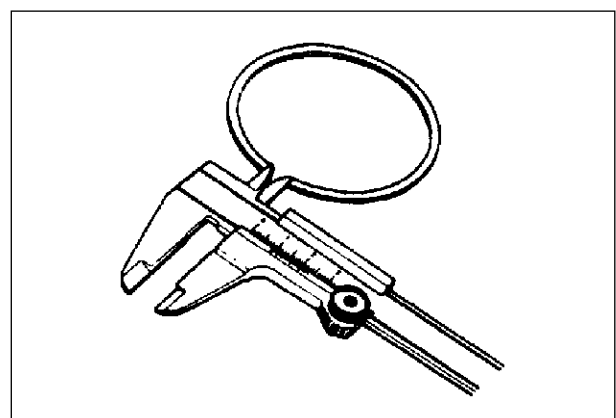

⊙ PISTON RING END GAP INSPECTION

Insert the piston ring squarely into the cylinder using the piston head.

Measure the end gap with a thickness gauge.

If the gap exceeds the service limit, replace the piston ring.

Piston ring end gap (Assembly condition)	Standard
1st	0.20~0.35 mm (0.008~0.013 in)
2nd	0.20~0.35 mm (0.008~0.013 in)

Piston ring end gap(Assembly condition)	Service limit
1st	0.5 mm (0.020 in)
2nd	0.7 mm (0.028 in)

 Thickness gauge : 0990-20806

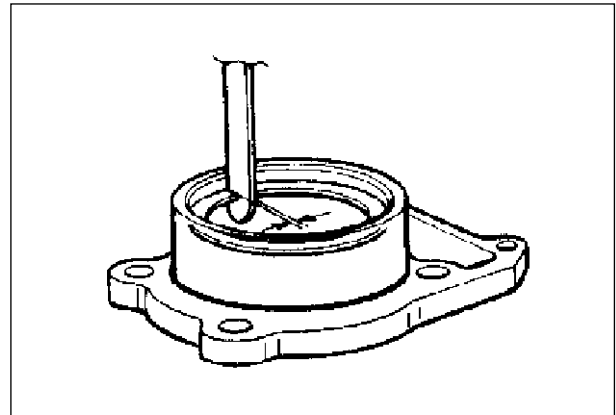

⊙ PISTON RING-TO-GROOVE CLEARANCE INSPECTION

Remove carbon deposit both from the piston ring and its groove.

Fit the piston ring into the groove. With the ring compressed and lifted up, measure the clearance on the bottom side of the ring using a thickness gauge.

Piston ring-groove clearance	Service limit
1st	0.180 mm (0.007 in)
2nd	0.150 mm (0.006 in)

Piston ring-groove width	Standard
1st	1.21 ~ 1.23 mm (0.0476 ~ 0.0484 in)
2nd	1.01 ~ 1.03 mm (0.040 ~ 0.041 in)
Oil	2.01 ~ 2.03 mm (0.079 ~ 0.080 in)

Piston ring thickness	Standard
1st	0.970 ~ 0.990 mm (0.0382 ~ 0.0390 in)
2nd	1.170 ~ 1.190 mm (0.0461 ~ 0.0469 in)

 Micrometer(0~25 mm) : 09900-20201
Thickness gauge : 09900-20806

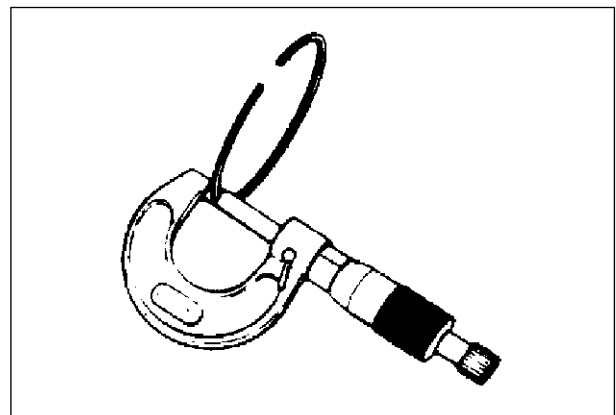
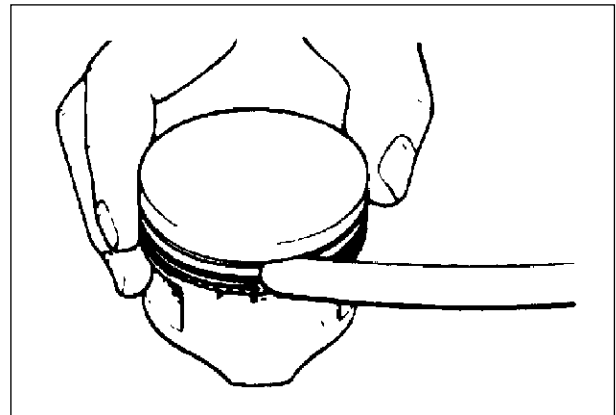

○ OVERSIZE RINGS

■ Oversize piston ring

The following two types of oversize piston ring are used. They bear the following identification numbers.

Oversize piston ring	1st	2nd
0.5 mm	05	05
1.0 mm	10	10

■ Oversize oil ring

The following two types of oversize oil ring are used. They bear the following identification marks.

Oversize oil ring	Color classification
0.5 mm	Painted red
1.0 mm	Painted yellow

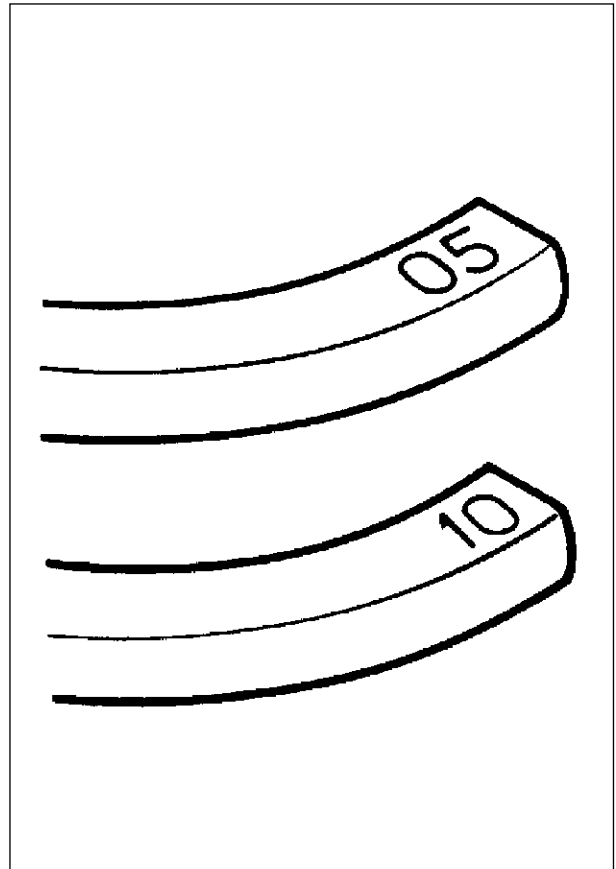

○ CONROD SMALL END INSIDE DIAMETER INSPECTION

Using a dial calipers, measure the conrod small end inside diameter both in vertical and horizontal directions. If any of the measurements exceeds the service limit, replace the conrod.

Conrod small end I.D.	Standard	Service limit
	20.006~20.014 mm (0.7876~0.7880 in)	20.040 mm (0.7890 in)

 Dial calipers : 09900-20605

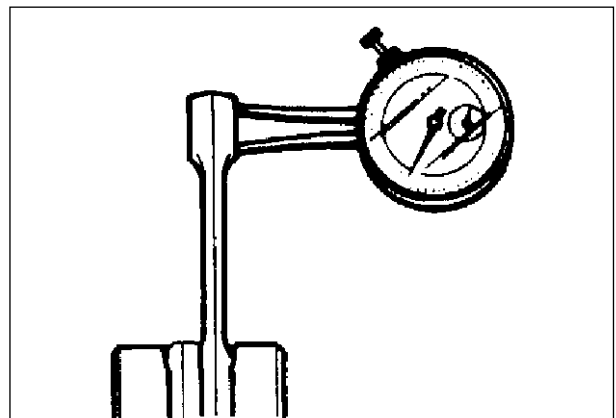

○ CONROD DEFLECTION INSPECTION

Move the small end sideways while holding the big end immovable in thrust direction.

Measure the amount of deflection.

Turn the conrod and see if it moves smoothly without play and noise. This method can check the extent of wear on the parts of the conrod's big end.

Conrod deflection	Service limit
	3.0 mm (0.12 in)

 Dial gauge : 09900-20606

Magnetic stand : 09900-20701

V-block : 09900-21304

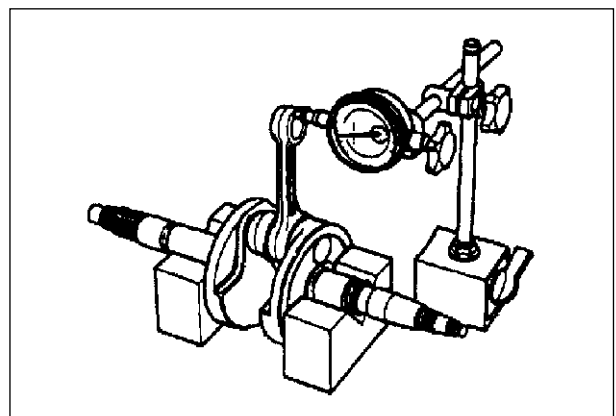

⊙ **CONROD BIG END SIDE CLEARANCE INSPECTION**

Using a thickness gauge, measure the side clearance at the conrod big end. If the measurement is out of standard value, measure the conrod big end and the crank pin widths individually to determine which one is to be replaced.

	Standard	Service limit
Conrod big end side clearance	0.17~0.32 mm (0.007~0.013 in)	0.50 mm (0.020 in)

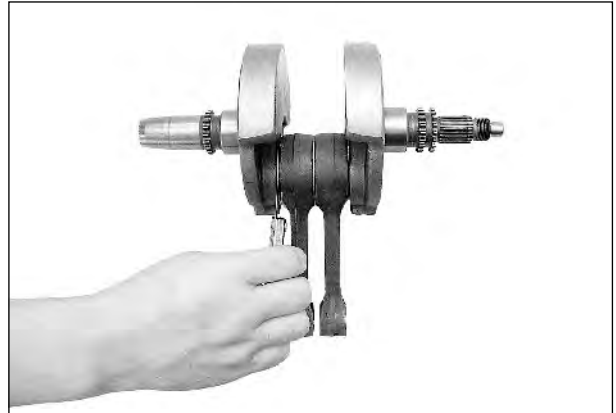

⊙ **CRANKSHAFT RUNOUT INSPECTION**

With the right and left crank journals supported with V-block, turn the crankshaft slowly. At this time, measure the crankshaft end runout using a dial gauge. If the runout exceeds the service limit, replace the crankshaft.

	Service limit
Crankshaft runout	0.05 mm (0.002 in)

-  Dial gauge : 09900-20606
- Magnetic stand : 09900-20701
- V-block : 09900-21304

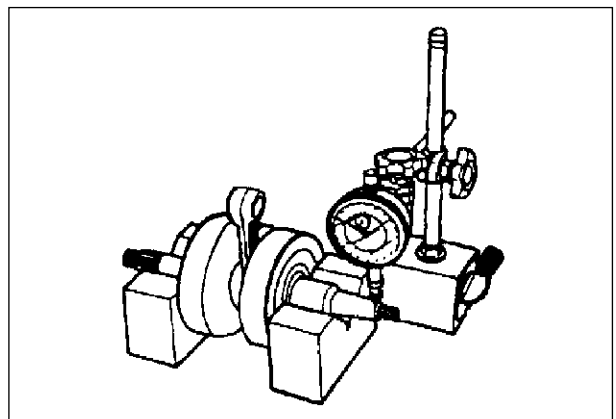

⊙ **CRANKSHAFT REASSEMBLY**

Measure the width between the webs referring to the figure below when rebuilding the crankshaft.

	Standard
Width between webs	96.9~97.1 mm (3.815~3.823 in)

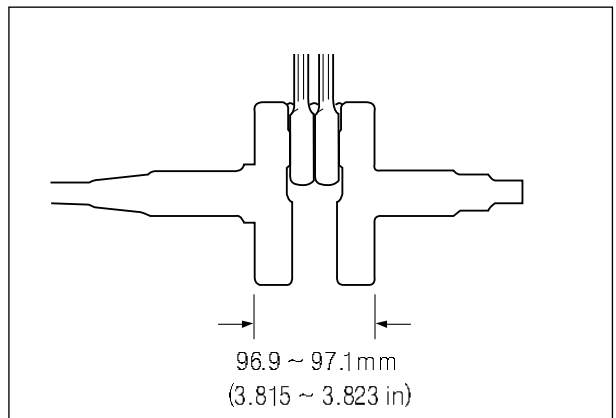

⊙ **MAGNETO COVER**
 ■ **MAGNETO INSPECTION**
 (Refer to page 7-4)

■ **DISASSEMBLY**

- Remove the stator ①.

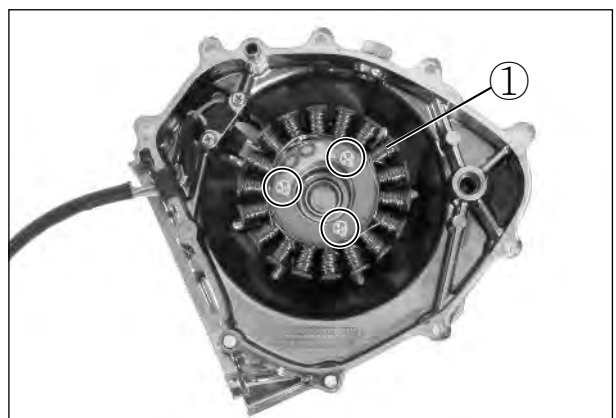

⊙ STARTER CLUTCH

Install the starter driven gear onto the starter clutch and turn the starter driven gear by hand (the gear turns in only one direction). The starter driven gear should turn smoothly. If excessive resistance is felt while turning the starter driven gear, inspect the starter clutch. Also, inspect the surface of the starter driven gear which contacts the starter clutch, for wear or damage. If any wear or damage is found, replace the defective parts.

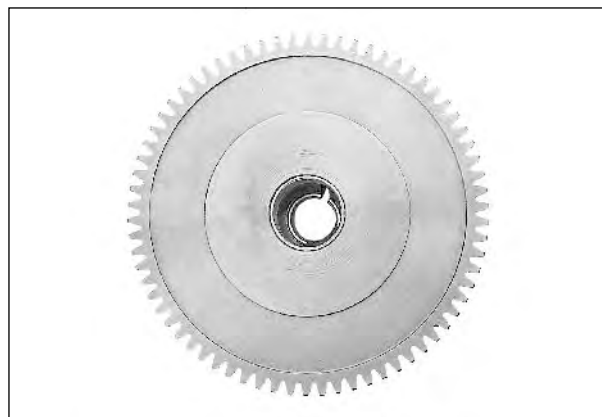

■ DISASSEMBLY

- With the magneto rotor held immovable, remove the starter clutch bolts.



■ REASSEMBLY

- Apply a small quantity of THREAD LOCK "1324" to the starter clutch bolts and tighten them to the specified torque with the magneto rotor held immovable.

 Thread Lock "1324"

 Starter clutch bolt

: 23 ~ 28 N · m (2.3 ~ 2.8 kgf · m)



⊙ STARTER DRIVEN GEAR

■ STARTER DRIVEN GEAR BUSH

Install the starter driven gear bush ① and gear ② onto the crankshaft and turn the starter driven gear by hand. Inspect the starter driven gear bush for smooth rotation and any abnormal noise. If the bush does not turn smoothly or there is any abnormal noise, replace it.

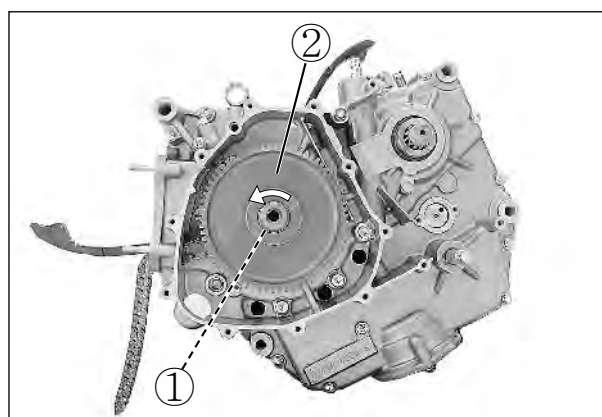

■ **DISASSEMBLY**

- Remove the bush using the special tool.

 **Bearing remover (20~35 mm)**
: 09923-74510



○ **OIL JET**

■ **REMOVAL**

- Remove the oil jet ①, ② from the right crankcase half.

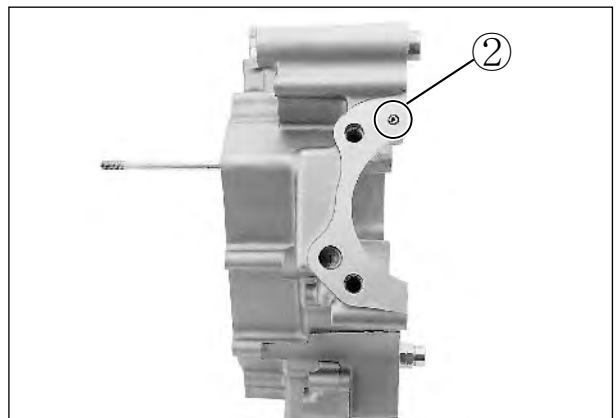
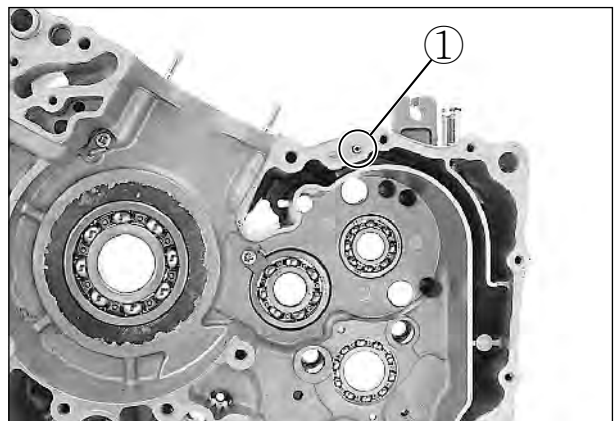

- Remove the oil jet ③ from the left crankcase half.

NOTE

If it is difficult to remove the oil jet, use a sting.

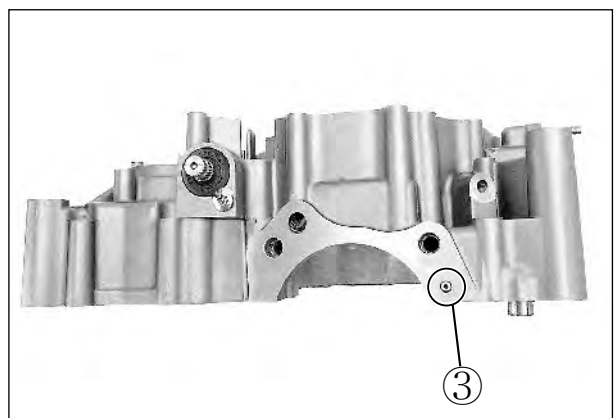

■ INSPECTION AND CLEANING

- Check the oil jets for clogging.
- If they are clogged, clean their oil passage with a proper wire and compressed air.



■ INSTALLATION

- Fit the new O-ring to each oil jets.



CAUTION

Use the new O-ring to prevent oil leakage.

- Apply engine oil to the O-ring.

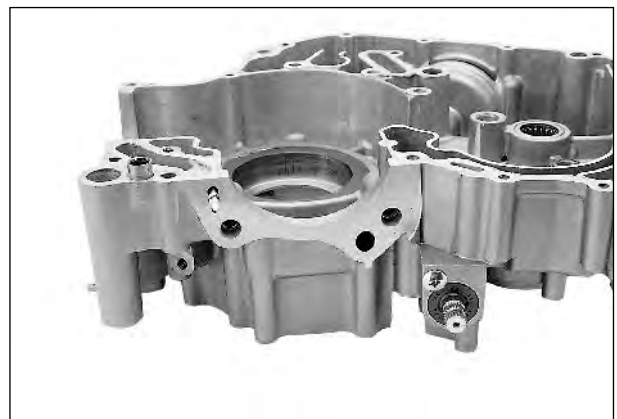

- Install the oil jet ① to the oil hole of crankcase.

NOTE

Push the oil jet the crankcase until it stops.

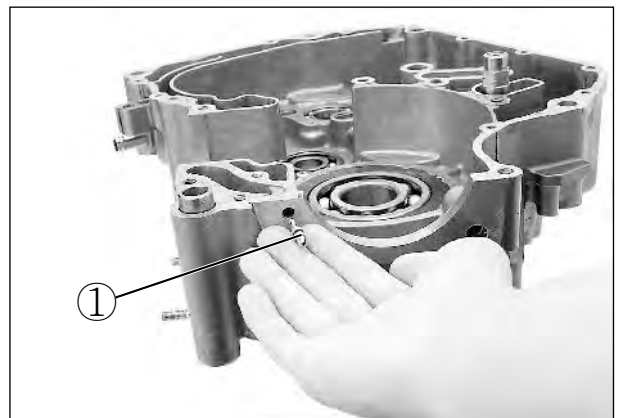

○ CLUTCH COVER

■ OIL FILTER REPLACEMENT

(Refer to page 2-14)

■ DISASSEMBLY

- Remove the circlip and right crankshaft oil seal.

 Oil seal remover : 09913-50121



▣ REASSEMBLY

- Drive in the oil seal using the special tool.

 **Bearing installer : 09913-75820**

- Install the circlip.



⊙ CLUTCH DRIVE PLATES

Measure the thickness and claw width of the clutch drive plates using vernier calipers. If a clutch drive plate is not within the service limit, replace the clutch plates as a set.

Clutch drive plate thickness	Standard	
	NO.1	2.92~3.08 mm (0.115~0.121 in)
	NO.2	3.42~3.58 mm (0.135~0.141 in)

Clutch drive plate thickness	Service limit	
	NO.1	2.62 mm (0.103 in)
	NO.2	3.12 mm (0.123 in)

Clutch drive plate claw width	Standard	
	NO.1	15.9~16.0 mm (0.626~0.630 in)
	NO.2	15.9~16.0 mm (0.626~0.630 in)

Clutch drive plate claw width	Service limit	
	NO.1	15.1 mm (0.595 in)
	NO.2	15.1 mm (0.595 in)

 **Vernier calipers : 09900-20101**

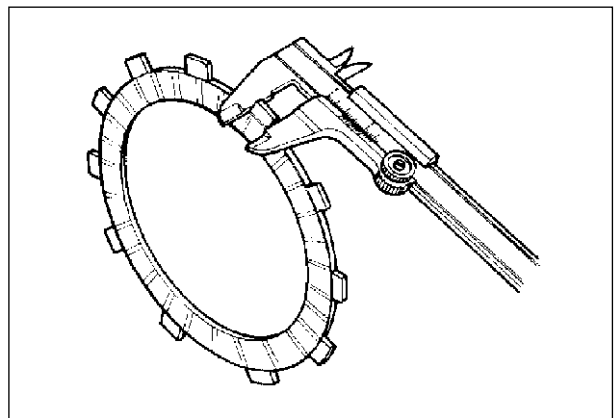
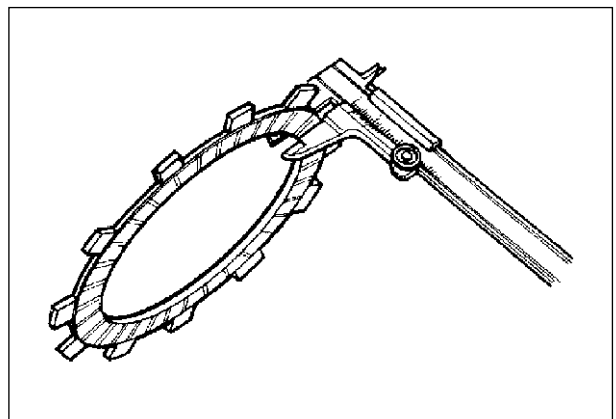

⊙ CLUTCH DRIVEN PLATES

Measure each clutch driven plate for distortion using the thickness gauge. If a clutch driven plate is not within the service limit, replace the clutch plates as a set.

Clutch driven plate distortion	Service limit
	0.1 mm (0.004 in)

 **Thickness gauge : 09900-20806**

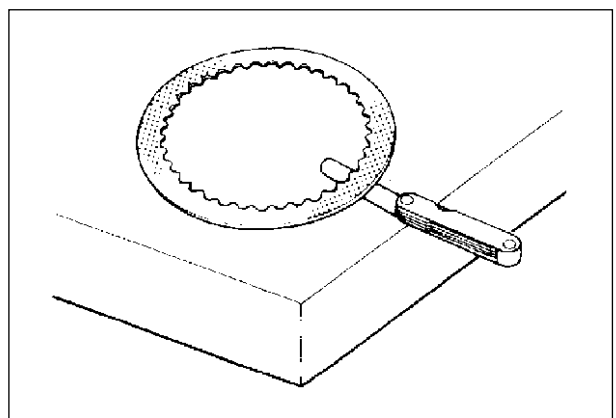

⦿ CLUTCH SPRING FREE LENGTH

Measure the free length of each clutch spring using vernier calipers. If any spring is not within the service limit, replace all of the spring.

Clutch spring free length	Service limit
	51 mm (2.008 in)

 Vernier calipers : 09900-20101

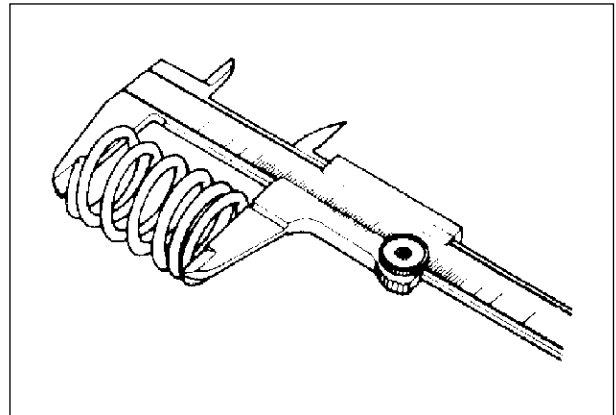

⦿ CLUTCH RELEASE BEARING

Inspect the clutch release bearing for any abnormality, especially cracks. When removing the bearing from the clutch, decide whether it can be reused or if it should be replaced.

Smooth engagement and disengagement of the clutch depends on the condition of this bearing.

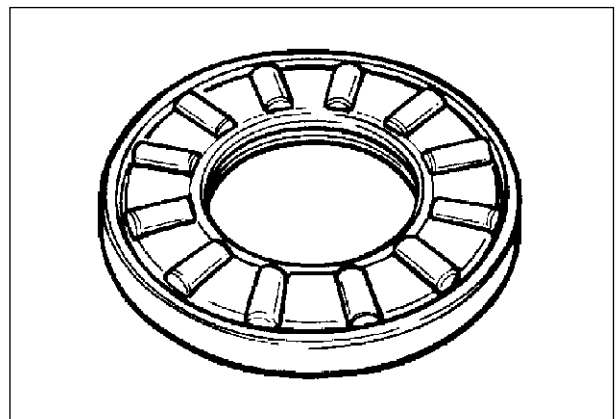

⦿ PRIMARY DRIVEN GEAR

Inspect the primary driven gear bearing for any damage. If any abnormal condition are found, replace the primary driven gear.



⦿ OIL PUMP

Turn the oil pump shaft and check that rotation is smooth. If any abnormal condition is found, replace the oil pump with new one.



⊙ **GEARSHIFT SHAFT**

Disassemble and reassemble the gearshift shaft as shown in right picture.

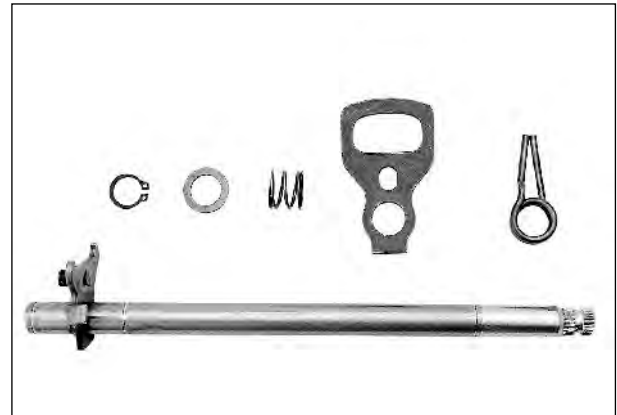

⊙ **TRANSMISSION**

▣ **INSPECTION**

◆ **GEAR-SHIFTING FORK**

Using a thickness gauge, check the clearance between the groove of its gear and shifting fork.

The clearance for each of the three shifting forks plays an important role in the smoothness and positiveness of shifting action.

If the clearance checked is noted to exceed the limit specified, replace the fork or its gear, or both.

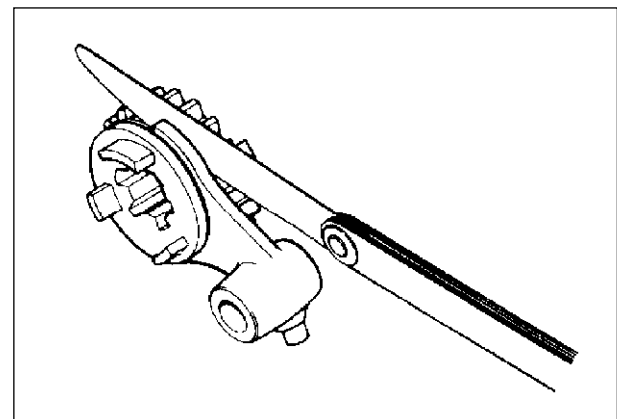

Shift fork-groove clearance	Standard	Service limit
	0.10~0.30 mm (0.004~0.012 in)	0.50 mm (0.020 in)

Shift fork groove width	Standard
NO.1 & NO.2	4.85~5.00 mm (0.191~0.197 in)
NO.3	4.85~5.00 mm (0.191~0.197 in)

Shift fork thickness	Standard
NO.1 & NO.2	5.3~5.4 mm (0.209~0.213 in)
NO.3	5.3~5.4 mm (0.209~0.213 in)

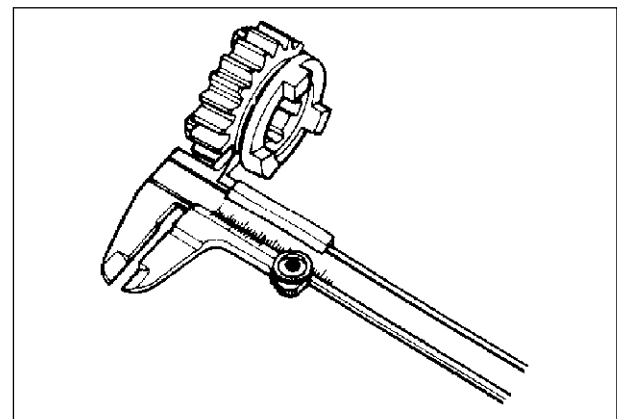

 Vernier calipers : 09900-20101
Thickness gauge : 09900-20806

▣ **REASSEMBLY**

Assemble the countershaft and drive shaft in the reverse order of disassembly. Pay attention to following points :

NOTE

Before installing the gears, coat lightly engine oil to the driveshaft and countershaft.

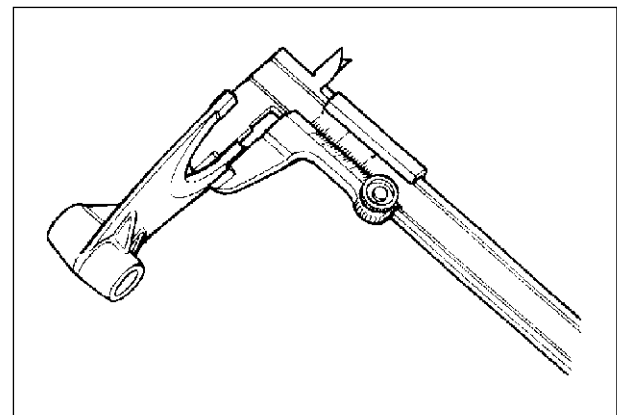

⚠ CAUTION

- ❖ Never reuse a circlip. After a circlip has been removed from a shaft, it should be discarded and a new circlip must be installed.
- ❖ When installing a new circlip, care must be taken not to expand the end gap larger than required to slip the circlip over the shaft.
- ❖ After installing a circlip, always ensure that it is completely seated in its groove and securely fitted.

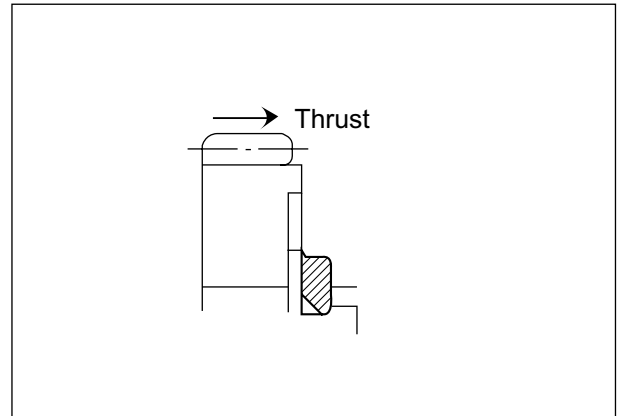

- When installing a new circlip, pay attention to the direction of the circlip. Fit it to the side where the thrust is as shown in figure.

■ TRANSMISSION GEARS AND RELATED PARTS

Thickness for washers, circlips and spacers

- Ⓐ 1.0mm
- Ⓑ 1.2mm
- Ⓒ 1.5mm

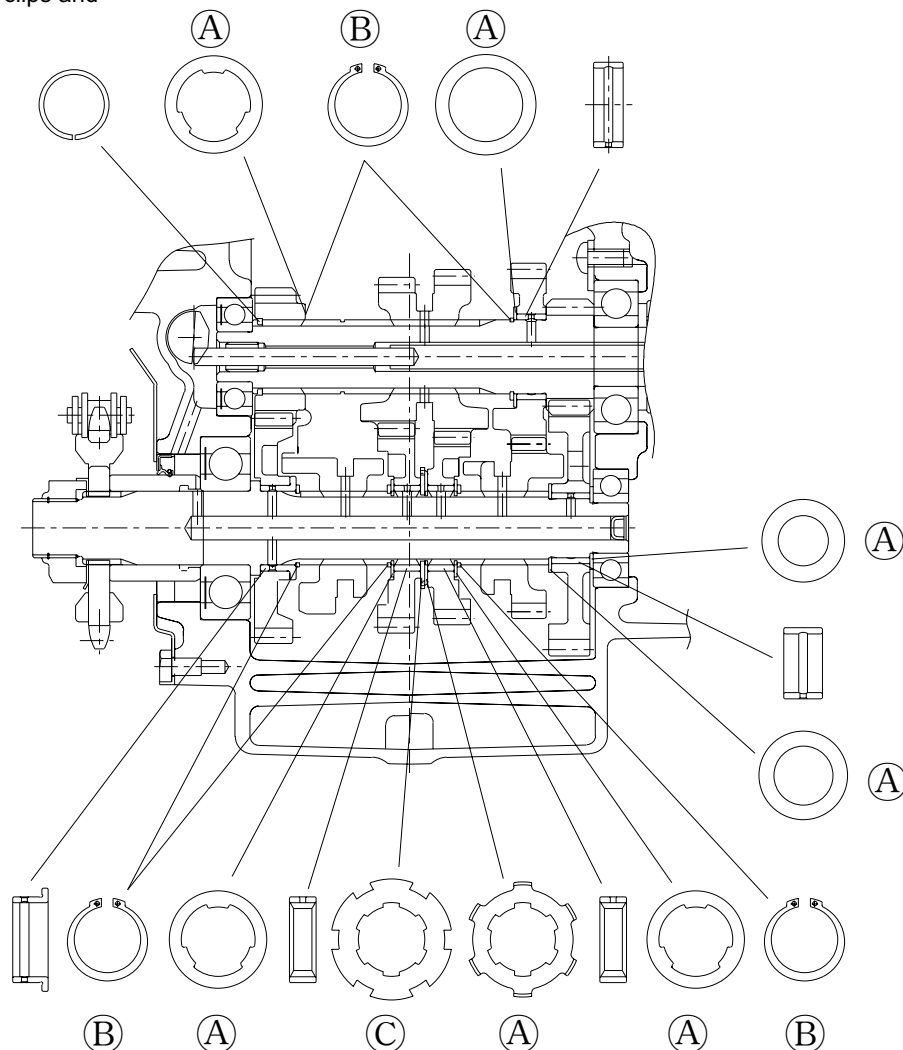

⊙ **CRANKCASE**
 ■ **BEARING INSPECTION**

Rotate the bearing inner race by finger to inspect for abnormal play, noise and smooth rotation while the bearings are in the crankcase.

Replace the bearing in the following procedure if there is anything unusual.

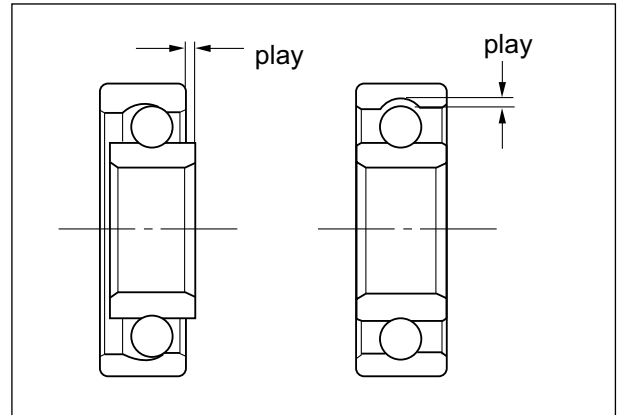

■ **DISASSEMBLY**
 ◆ **RIGHT CRANKCASE BEARING**

- Remove the bearing retainer bolt ①, ②, and ③.
- Remove the bearing retainer.

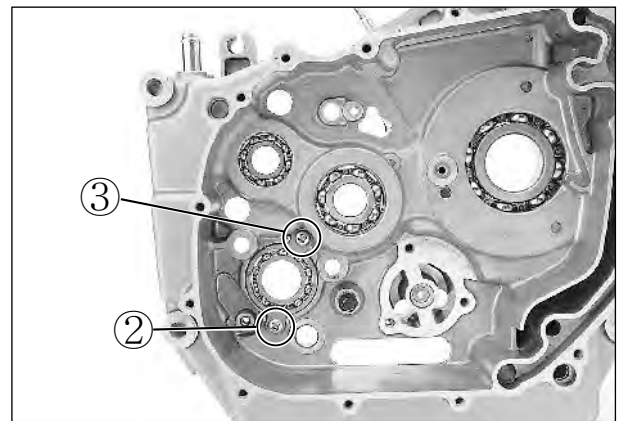
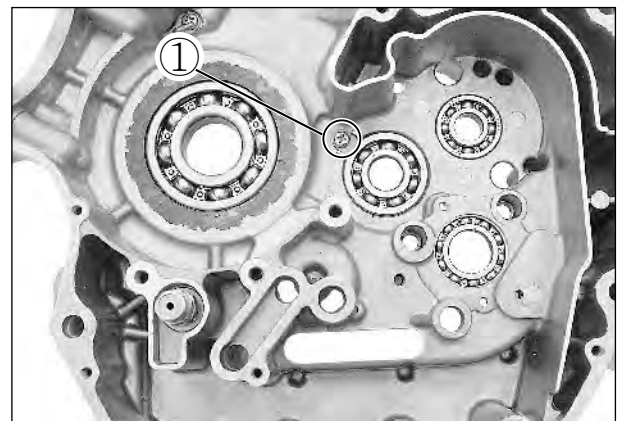

- Remove the bearings ④, ⑤ and ⑥.

- TOOL Bearing remover (17 mm) : 09923-73210
 Bearing remover (20~35 mm) : 09923-74510

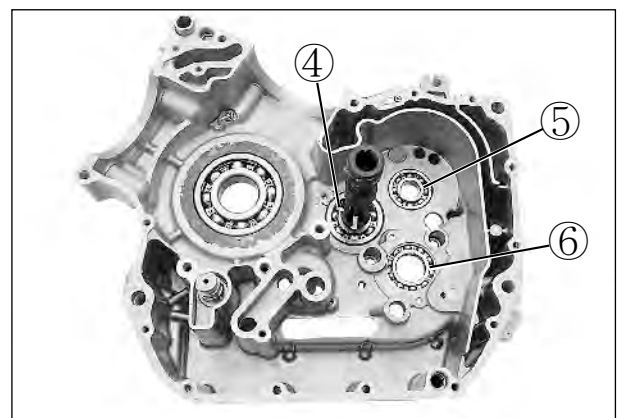

- Remove the bearing ①.

 Bearing installer : 09913-76010

 **CAUTION**

The removed bearing should be replaced with a new one.

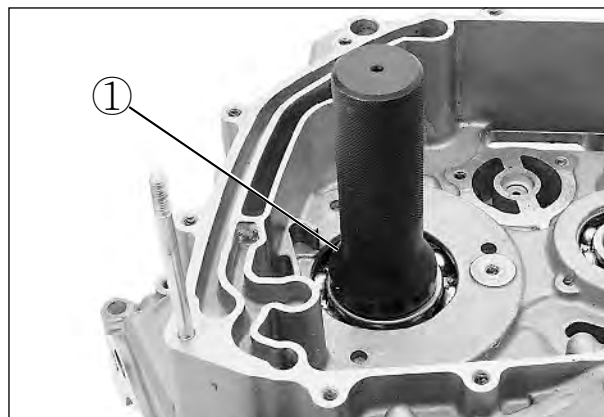

◆ **LEFT CRANKCASE BEARING**

- Remove the oil seals ② and ③.

 Oil seal remover : 09913-50121

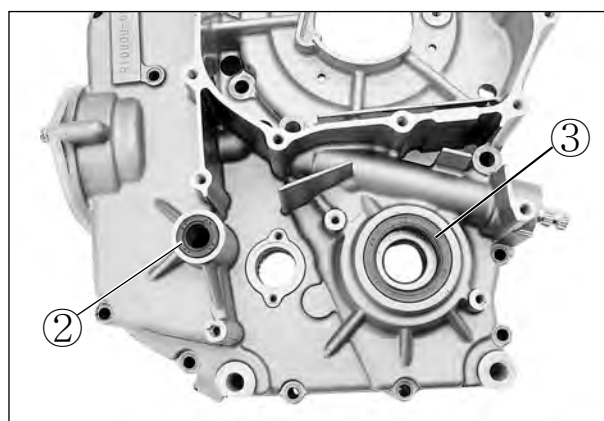

- Remove the bearings ④, ⑤, and ⑥.

 Bearing remover (17 mm) : 09923-73210

Bearing remover (20~35 mm)

: 09923-74510

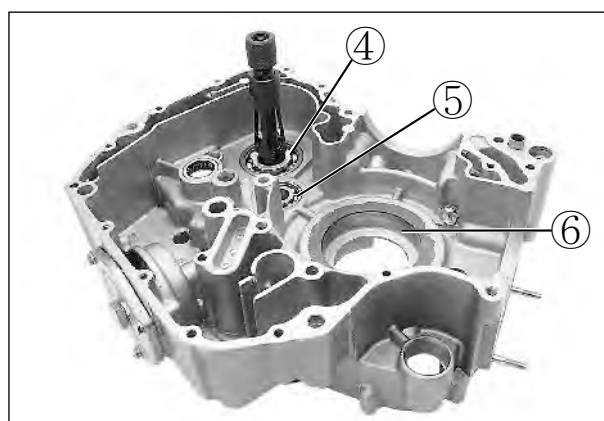

■ **REASSEMBLY**

◆ **RIGHT CRANKCASE BEARING**

- Drive in the bearings ⑦, ⑧, ⑨ and ⑩.

 Bearing installer : 09913-70122

Bearing installer : 09913-76010

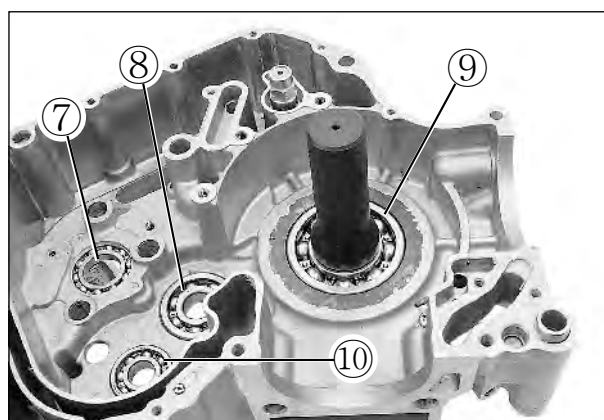

◆ LEFT CRANKCASE BEARING

- Drive in the bearings ①, ② and ③.

 Bearing installer : 09913-70122
 Bearing installer : 09913-76010

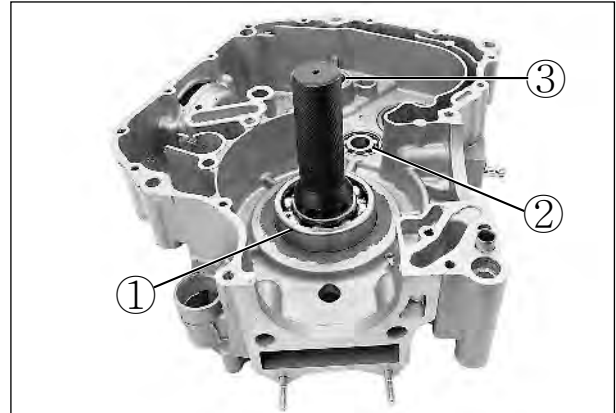

- Install the oil seals ④ and ⑤.
- Apply SUPER GREASE "A" on the lip of oil seal.

 SUPER GREASE "A"



ENGINE REASSEMBLY

The engine reassembly can be performed in the reverse order of disassembly procedures. However, the following points must be observed in the reassembly operation.

 CAUTION

Make sure to coat the rotating and sliding sections with engine oil.

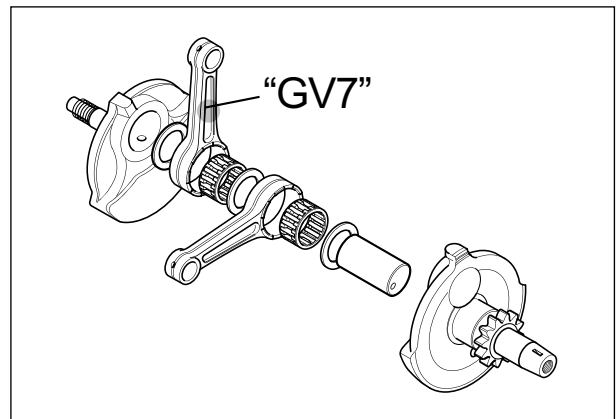

● CRANKSHAFT

NOTE

『ST7』's crankshaft is imprinted with the "GV7" letters.

- Using the special tool, press the crankshaft into the left crankcase.

 Crankshaft installer : 09910-32812
 Crankshaft installer adapter : 09910-32813

 CAUTION

Never fit the crankshaft into crankcase by striking it with a plastic hammer.
 Always use the special tool, otherwise crankshaft alignment accuracy will be affected.



⊙ TRANSMISSION

- Install the transmission.

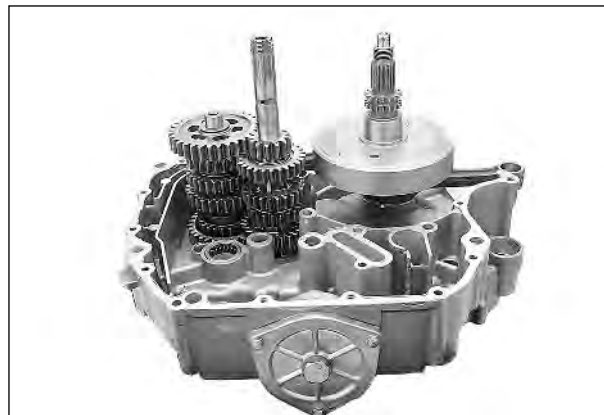

⊙ GEARSHIFT CAM AND GEARSHIFT FORKS

- Install the gearshift fork NO.1 ①, NO.2 ②, and NO.3 ③.

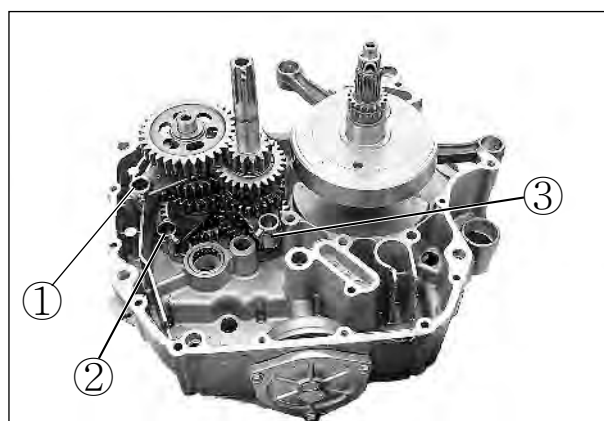
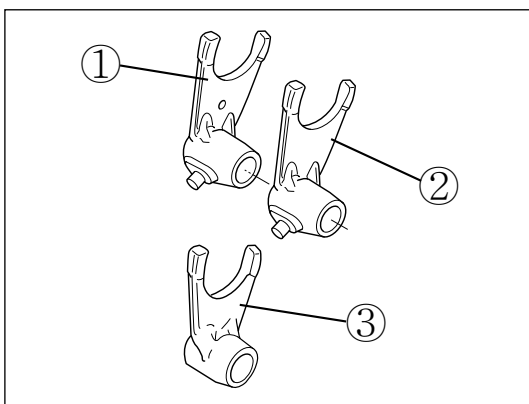

- Install the gearshift cam ④, and gearshift fork shaft ⑤, ⑥.

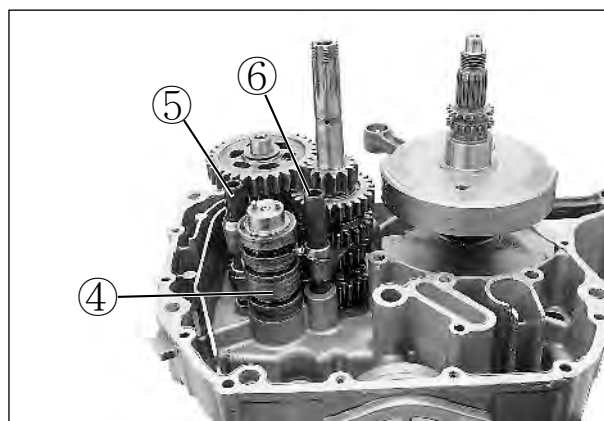

- Install the dowel pins ⑦.
- Before assembling the crankcase, apply the engine oil to each gear and bearing.

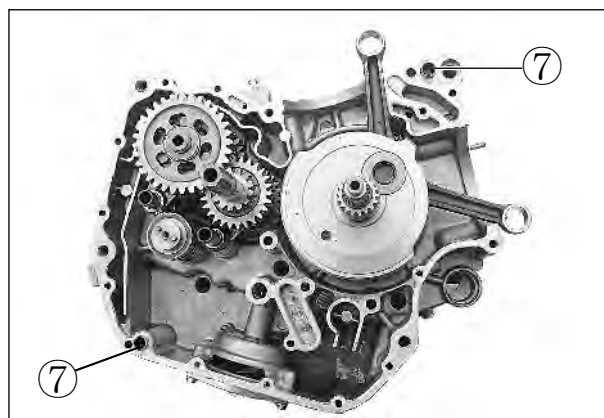

- Apply BOND "1215" to the right crankcase.

 BOND "1215"

 **CAUTION**

- ❖ Application of BOND "1215" must be performed within a short period of time.
- ❖ Take extreme care not to let BOND "1215" enter into the oil hole or bearing.

- Install the crankcase.
- Install the crankcase bolts, right and left.

 **Crankcase bolt (M6)**
: 11 N · m (1.1 kgf · m)

Crankcase bolt (M8)
: 26 N · m (2.6 kgf · m)

NOTE

Tightening the crankcase bolts, tighten each bolt little by little diagonally.

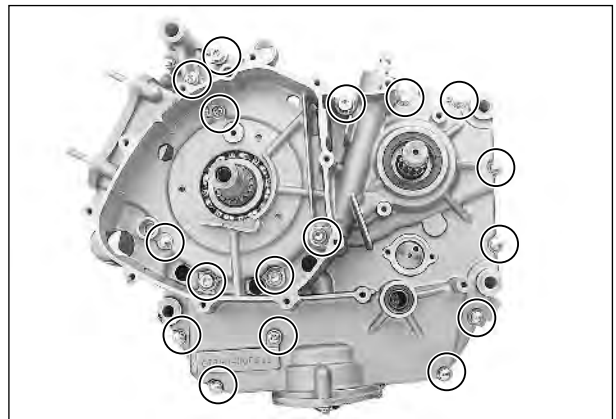

NOTE

- ❖ After the crankcase bolts have been tightened, make sure that the crankshaft, countershaft and driveshaft rotate smoothly.
- ❖ If these shafts do not rotate smoothly, try to free it by tapping with a plastic hammer.

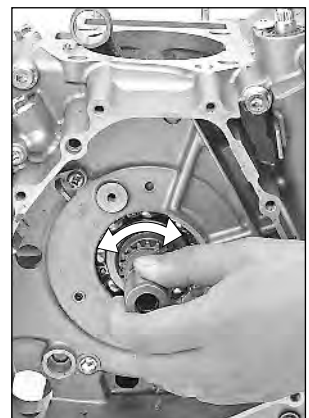
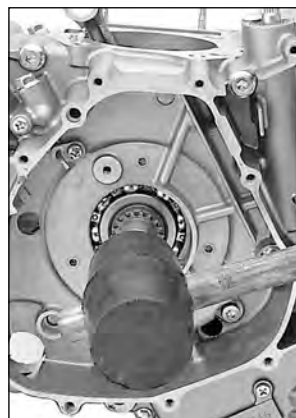

- Apply the **SUPER GREASE "A"** to the driveshaft O-ring and oil seal lip.

 **SUPER GREASE "A"**

- Install the driveshaft spacer.

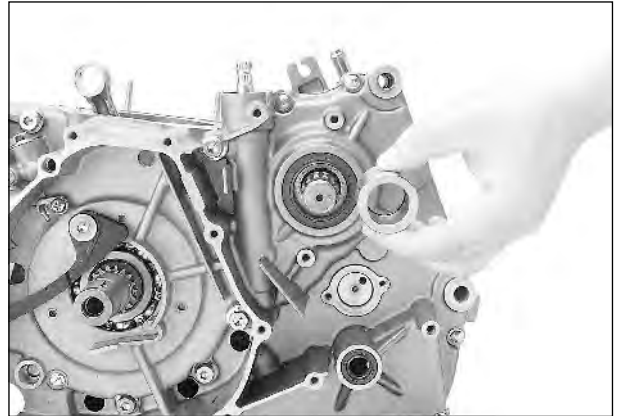

- Install the oil seal retainer.

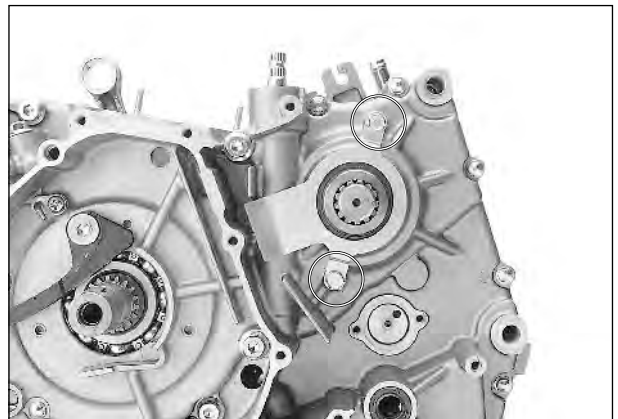

 **GEARSHIFT CAM STOPPER**

- Apply a small quantity **THREAD LOCK "1324"** to the gearshift cam plate bolt ①.

 **THREAD LOCK "1324"**

- Install the gearshift cam stopper plate and gearshift cam plate bolt ①.
- Install the gearshift cam stopper ②.

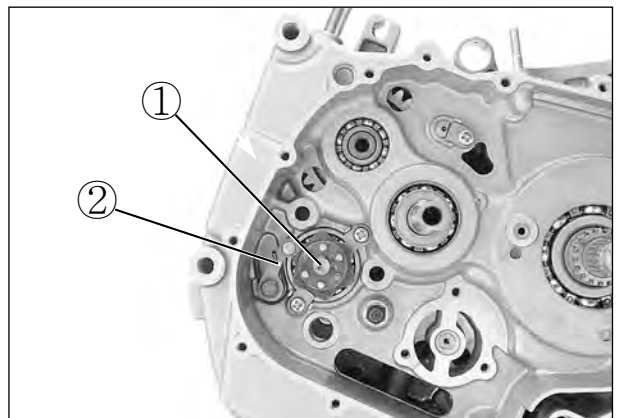

 **GEARSHIFT SHAFT**

- Install the gearshift shaft ③.

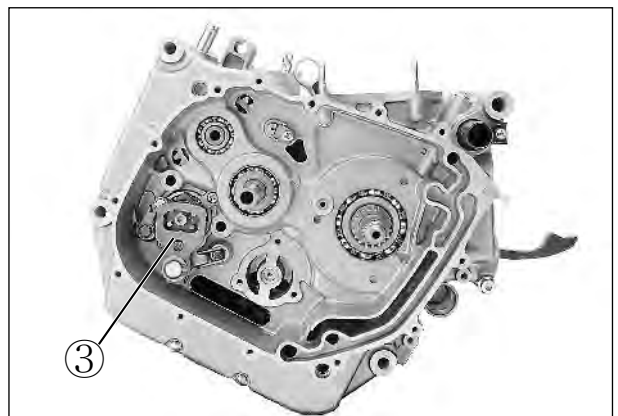

⚠ CAUTION

After the cam driven gear, cam guide, gearshift shaft and neutral cam stopper have been fitted, confirm that gear change is normal while turning the countshaft and driveshaft. If gear change is not obtained, it means that assembly of gears or installation of gear shifting fork is incorrect. In this case, disassemble and trace the mistake.

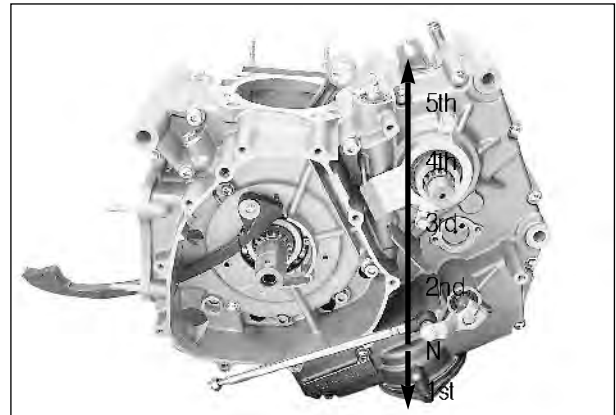

⊙ OIL PUMP

- Before installing the oil pump, apply the engine oil to the contact face of case, outer rotor, inner rotor and shaft.
- Apply a small quantity **THREAD LOCK "1324"** to the oil pump securing screws.
- **1324 THREAD LOCK "1324"**
- Tighten the oil pump securing screws.
- Install the oil pump shim and pin.

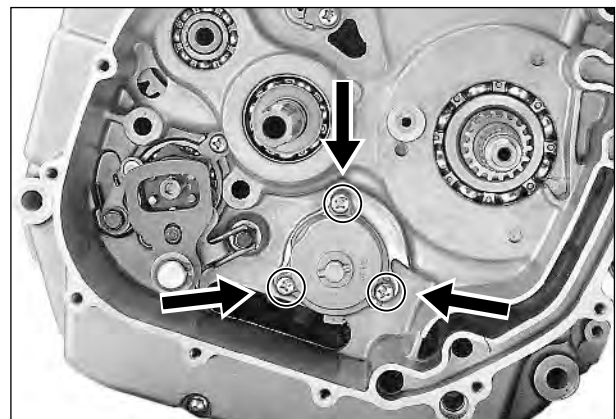

- Put in the oil pump driven gear, and install the circlip.

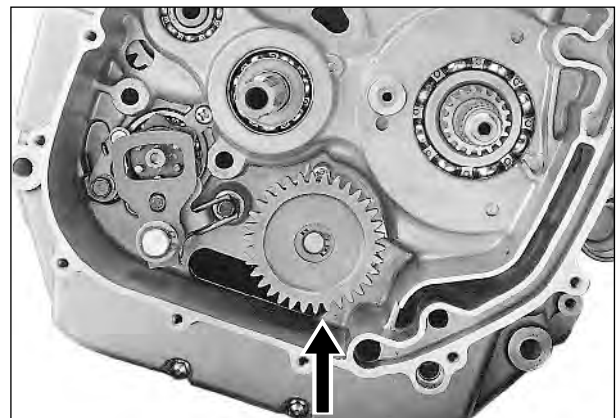

⚠ CAUTION

When installing the oil pump to the crankcase, turn the pump gear and check that rotation is smooth by the hand.

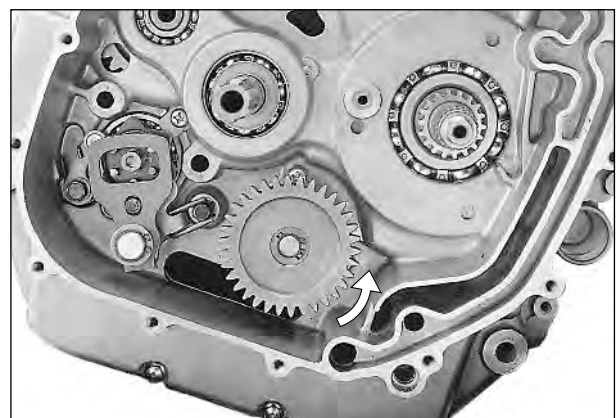

⊙ CAM CHAIN TENSIONER

- Install the washer and cam chain tensioner ②, tighten the cam chain tensioner bolt ①.



Cam chain tensioner bolt

: 8 ~ 12 N · m (0.8 ~ 1.2 kgf · m)

- Install the cam chain ③.

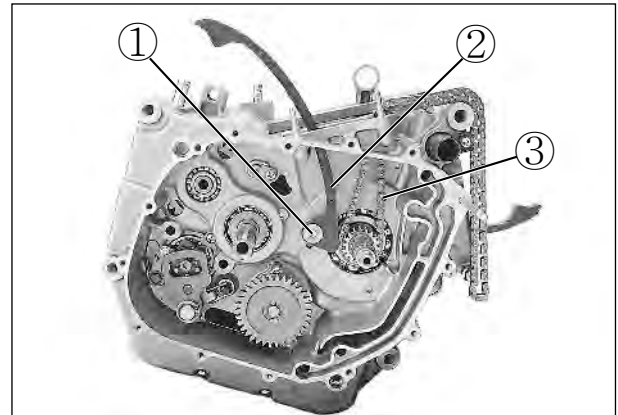

⊙ PRIMARY DRIVE GEAR

- Install the primary drive gear and NO.2 gear to the crankshaft, put the key to the key groove.



CAUTION

When installing the NO.2 gear, install so that the mark on the gear align the key groove as shown in figure.

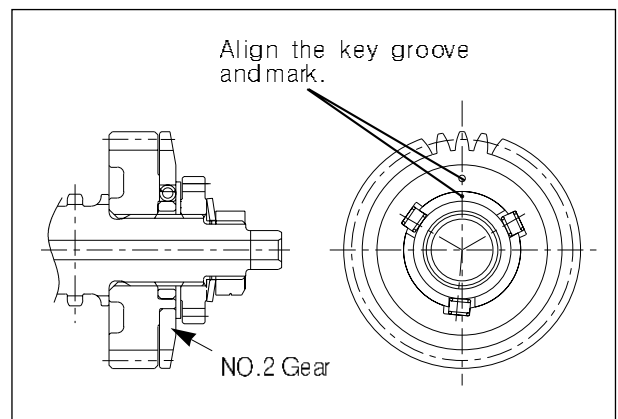

CAUTION

Pay attention to the each washer to lower end of the water pump drive gear and primary drive gear nut in times of assemblage.

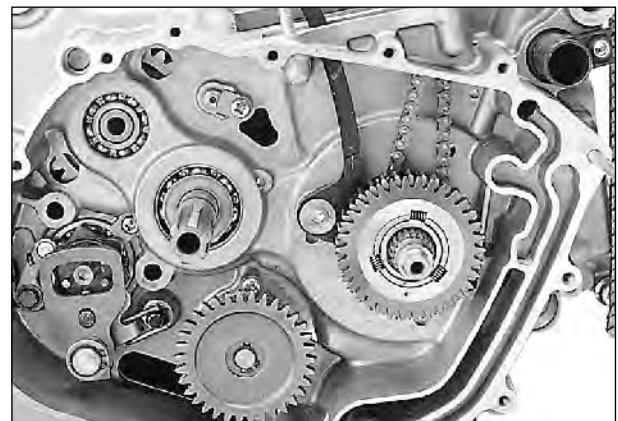

- With the crankshaft held immovable using special tool, install the water pump drive gear ④ and primary drive gear nut ⑤.



Conrod holder : 09910-20115



Primary drive gear nut

: 40 ~ 60 N · m (4.0 ~ 6.0 kgf · m)

NOTE

The primary drive gear nut has left-hand thread.

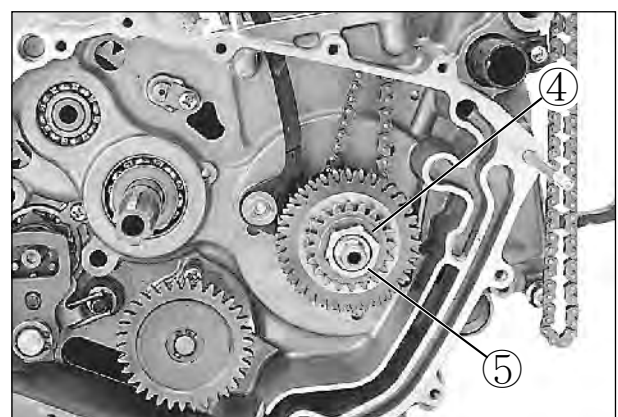

⊙ PRIMARY DRIVEN GEAR

NOTE

Apply the engine oil to the inside face of primary driven gear bearing.

- Install the primary driven gear assembly.



⊙ CLUTCH

- Install the clutch sleeve hub ①, lock washer ②.

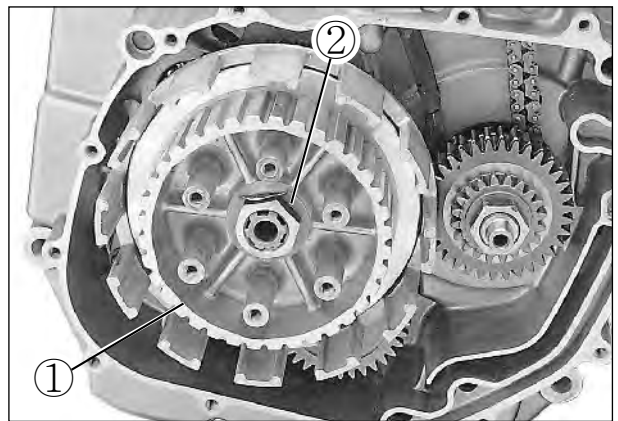

- Install the clutch sleeve hub nut, and tighten it to the specified torque using the special tool.

 **Clutch sleeve hub holder : 09920-53710**

 **Clutch sleeve hub nut**
: 40 ~ 60 N · m (4.0 ~ 6.0 kgf · m)

- Bend the lock washer securely.

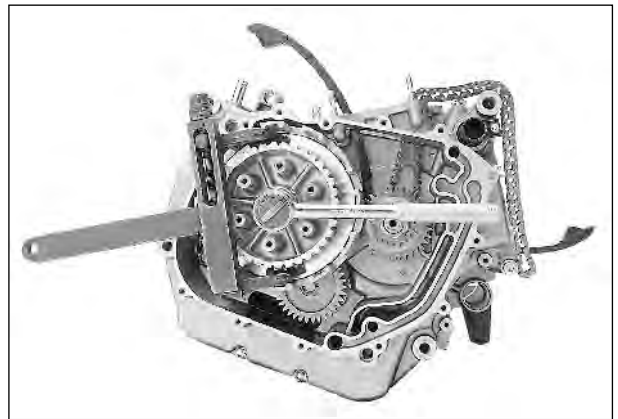

- Install the clutch drive plate NO. 2 ④.
- Install the spring washer seat ⑤ and spring washer ⑥ onto the clutch sleeve hub correctly.
- Install the clutch driven plates ⑦ and drive plates NO. 1 ⑧ one by one into the clutch sleeve hub in the prescribed order.

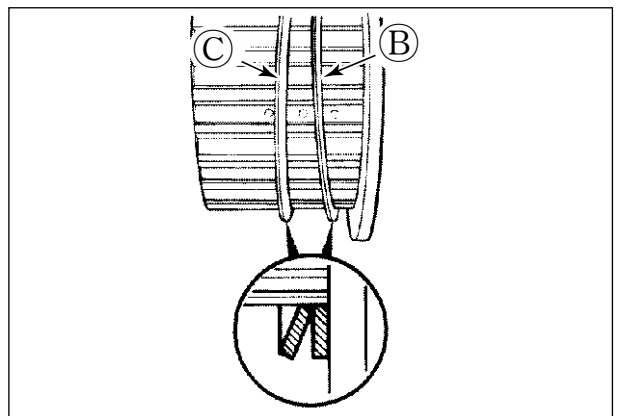

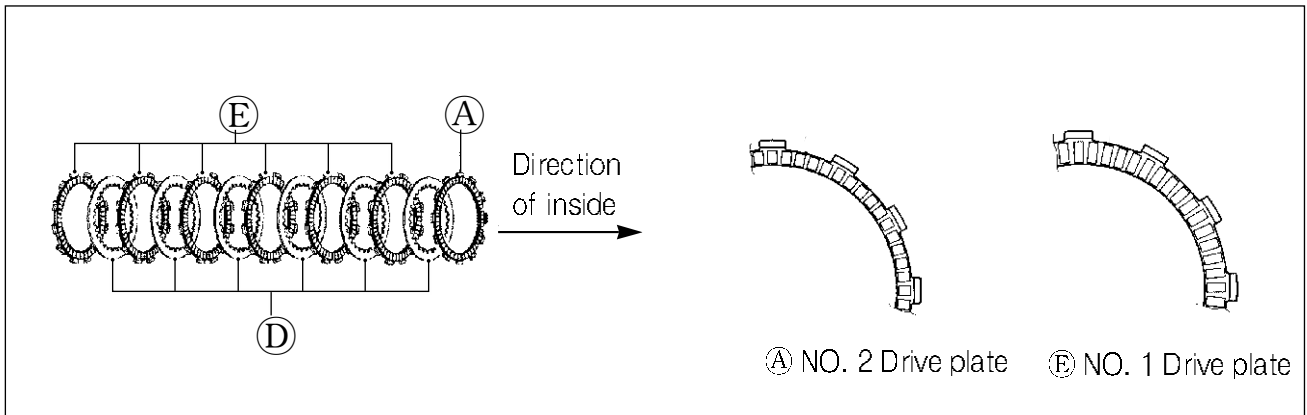

- Install the clutch release rack ①, bearing ② and washer ③.

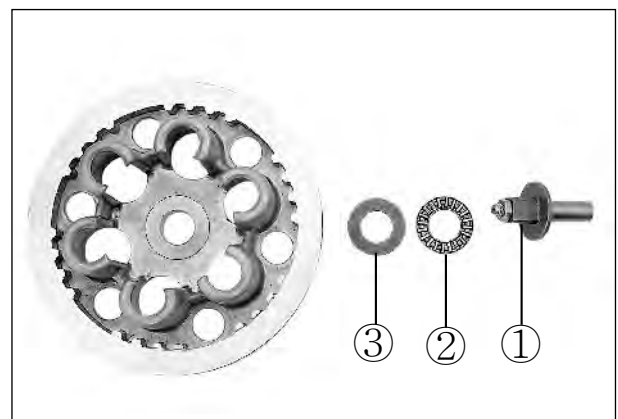

- Install the clutch pressure plate ④, retainer, clutch springs and clutch spring mounting bolts.
- Hold the primary drive gear nut and tighten the clutch spring mounting bolts in a crisscross pattern.

NOTE

Make sure that the clutch pressure plate is installed correctly.

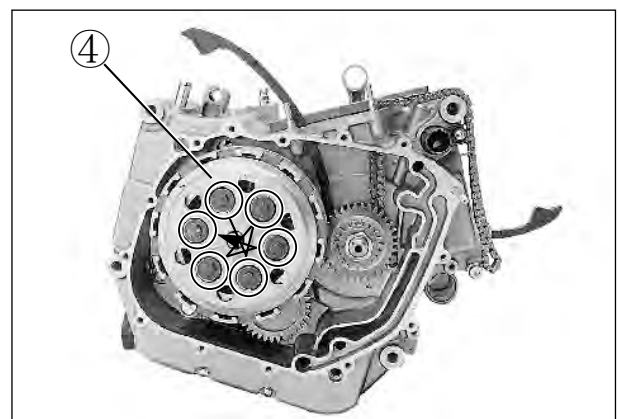

▣ **CLUTCH COVER**

- Install the two dowel pins ⑤ and new gasket ⑥.
- Apply engine oil to each gears, bearings and clutch plates.

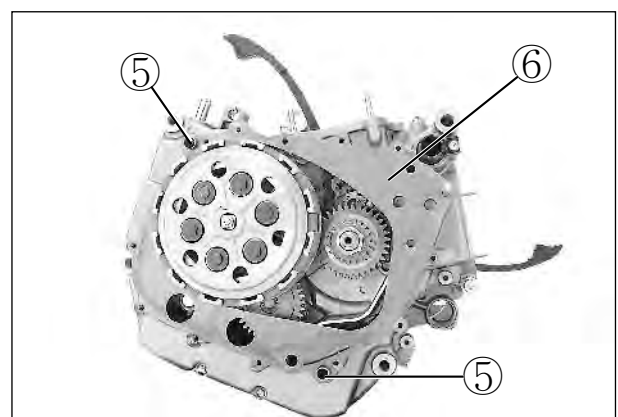

3-49 ENGINE

- Install the clutch cover, and tighten the clutch cover bolts securely.

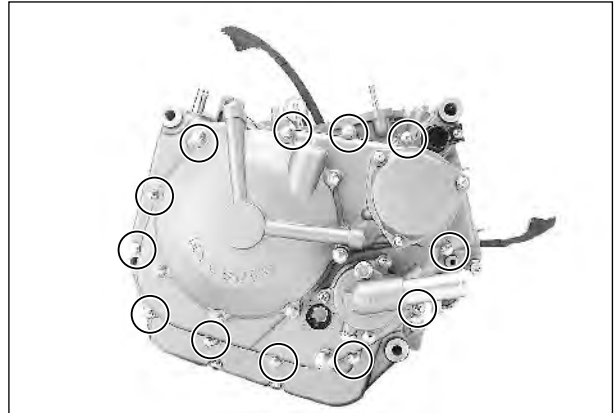

- Install the clutch release arm as following :
 - ① Turn the clutch release shaft toward(This time, mark on the shaft align outside contact line the stopper screw) the right.
 - ② Install that the release camshaft notch mark align matching mark of the crankcase as shown in the right figure.

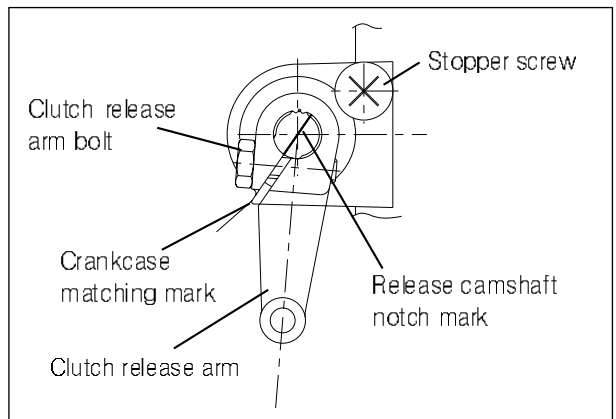

⊙ OIL DRAIN PLUG

- Tighten the oil drain plug to the specified torque.

 **Engine oil drain plug**
: 21 N · m (2.1 kgf · m)

⊙ STATOR

- Apply a small quantity of **THREAD LOCK "1324"** to the threaded parts of screws.

 **THREAD LOCK "1324"**



⊙ STARTER CLUTCH

- When installing the starter clutch and rotor, apply the **THREAD LOCK "1324"** to the bolts and tighten to the specified torque.

 **THREAD LOCK "1324"**

 **Starter clutch bolt**
: 23 ~ 28 N · m (2.3 ~ 2.8 kgf · m)

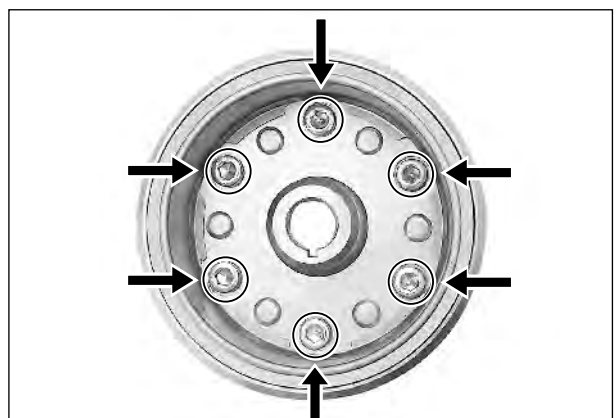

○ MAGNETO ROTOR

- Fit the key into the key slot on the crankshaft.
- With the magneto rotor, install the starter clutch on the crankshaft.
- Apply a small quantity of **THREAD LOCK "1324"** to the threaded parts of crankshaft.

 **THREAD LOCK "1324"**

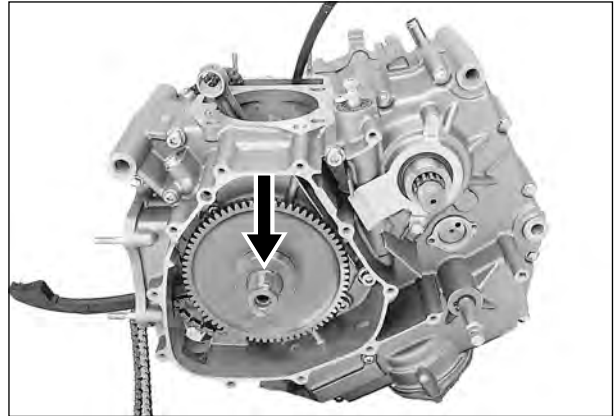

- Tighten the magneto rotor bolt to the specified torque.

 **Conrod holder : 09910-20115**

 **Magneto rotor bolt**
: 110 ~ 170 N · m (11.0 ~ 17.0 kgf · m)

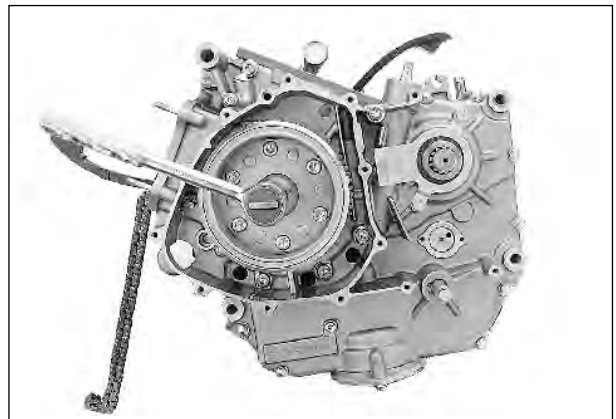

○ STARTER IDLE GEAR AND MOTOR

- Install the starter idle gear, shaft.

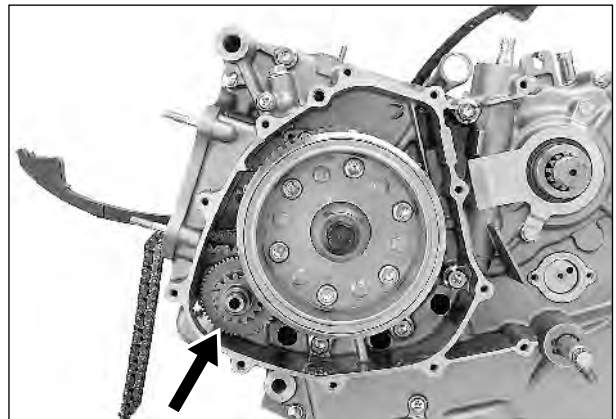

- Install the starter motor.

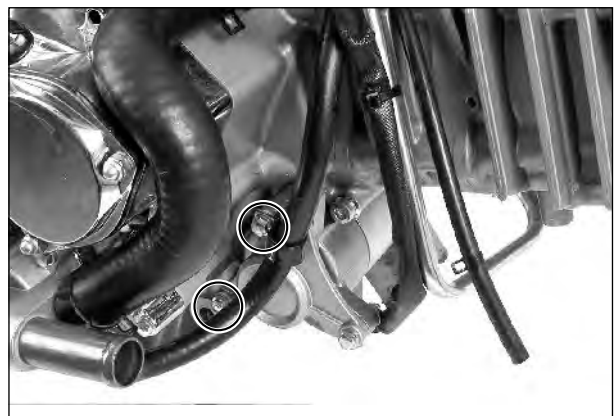

⊙ MAGNETO COVER

- Install the new gasket and dowel pin.
- Apply oil to the each gear, bearing and starter clutch.

- Install the magneto cover and tighten the magneto cover bolts.



Magneto cover bolt

: 10 N · m (1.0 kgf · m)

⊙ PISTON RING

- First, install the piston ring in order of oil ring, 2nd ring and 1st ring at the front cylinder.

⚠ CAUTION

Be careful not to cause scratch on the piston when inserting the piston ring to the piston. Also, do not expand the piston ring more than necessary as the ring can break.

- When all the piston rings have been assembled, check that each can turn smoothly.
- To minimize compression and oil leaks, locate each piston ring end gap in the position as shown in the right illustration
- Install the spacer ①.
- Install the upper and lower side rail ②.

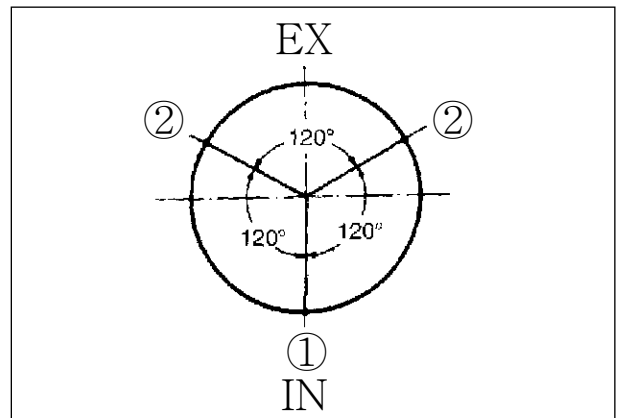
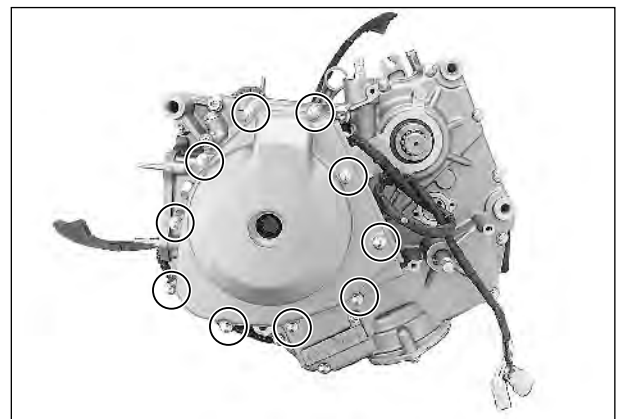
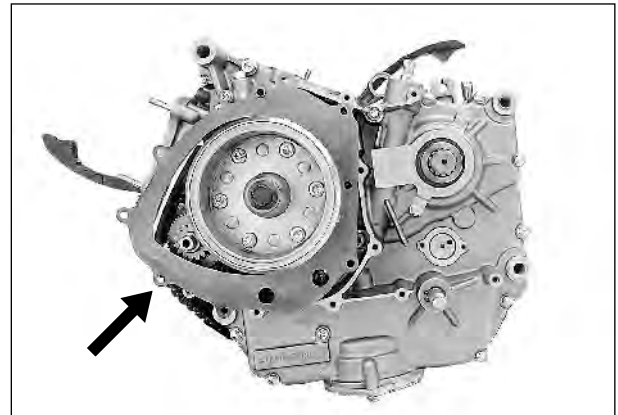
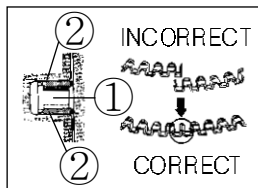

⊙ PISTON

- Apply the **MOLY PASTE** to the piston pin.



MOLY PASTE

- When installing the piston, turn the mark (A) on the piston head to exhaust side.
- After the piston pin has been inserted through the conrod, install the circlip (3).

⚠ CAUTION

Replace the circlip with a new one. Place a piece of rag under the piston when installing the circlip to prevent it from falling into the crankcase.

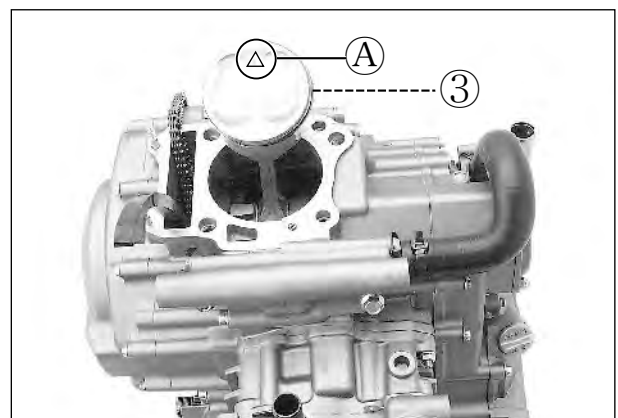

○ CYLINDER

- Apply BOND "1215" to the parting line of crankcase.

 BOND "1215"

- Place the dowel pin ① and new gasket on the crankcase.

CAUTION

Make sure to replace the gasket with a new one.

- Apply the engine oil to the conrod small end, piston and the piston rings.
- Coat the cylinder wall with oil.
- Install the cylinder and tighten the cylinder base nuts.

Cylinder base nut

: 7 ~ 11 N · m (0.7 ~ 1.1 kgf · m)

This cylinder is different from the front and rear.

○ VALVE AND SPRING

- Insert the valve, with their stems coated with MOLY PASTE.

MOLY PASTE

Apply the oil to the lip of the stem seal.

- The narrow pitch side of each spring face to the head when the valve spring install. The pitch of inside spring and outside spring is changed. The pitch of spring is decreased from the upper side to the lower side.

○ CYLINDER HEAD

- Put the valve spring and retainer and install the valve cotter with compressed the spring by using the valve spring compressor.

Valve spring compressor

: 09916-14510

Valve spring compressor attachment

: 09916-14520

CAUTION

After installing the valve cotter, tap the valve stem end by using the plastic hammer at 2~3 times for assembly of the valve and cotter.

- Fit the cylinder head and tighten the six cylinder head bolts diagonally.

Cylinder head bolt (M6)

: 8 ~ 12 N · m (0.8 ~ 1.2 kgf · m)

Cylinder head bolt (M10)

: 40 ~ 45 N · m (4.0 ~ 4.5 kgf · m)

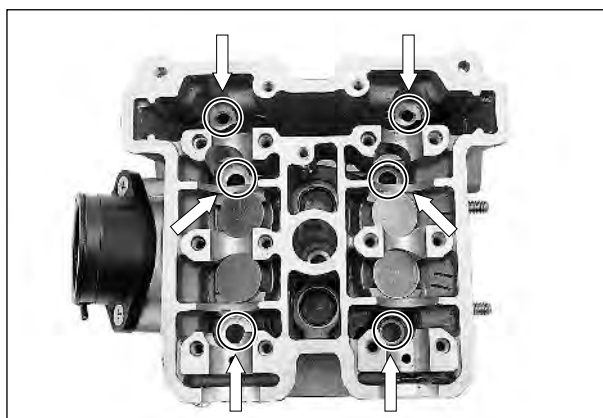
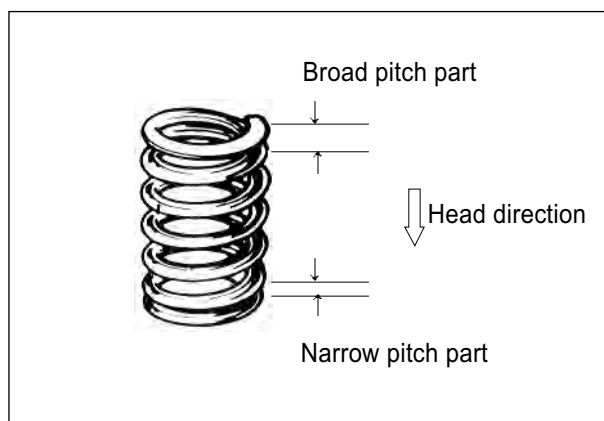
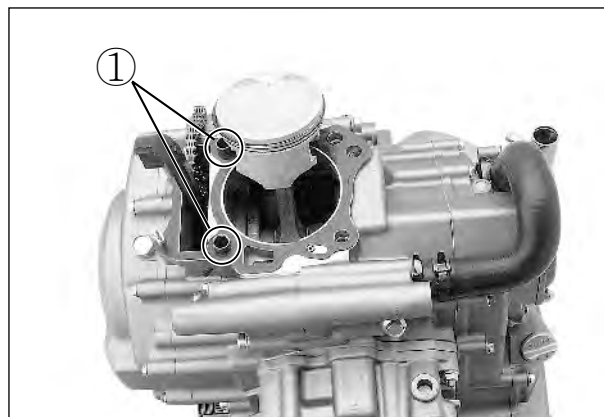

⚠ CAUTION

Pay caution to prevent the cam chain from dropping into the crankcase.

- Tighten the cylinder head base bolt.

🔧 Cylinder head base bolt
: 8 ~ 12 N · m (0.8 ~ 1.2 kgf · m)

- Install the tappet and shim.

⚠ CAUTION

With the tappet fitted, it should be replaced if it doesn't turn smoothly by the hand.

⚠ CAUTION

The tappet and shim should be installed at the original position when removed. If otherwise, it is difficult to adjust the valve clearance.

- Fit the chain guide.

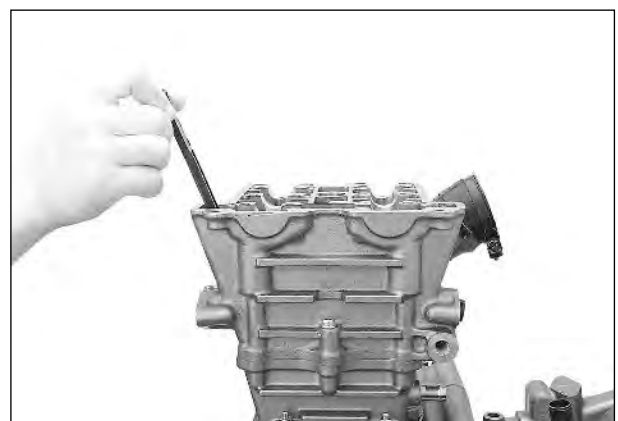
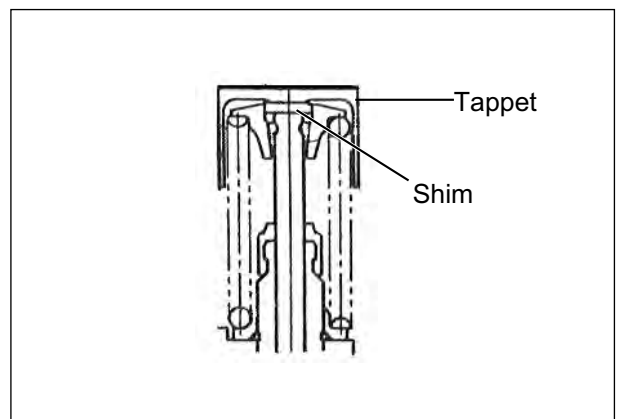
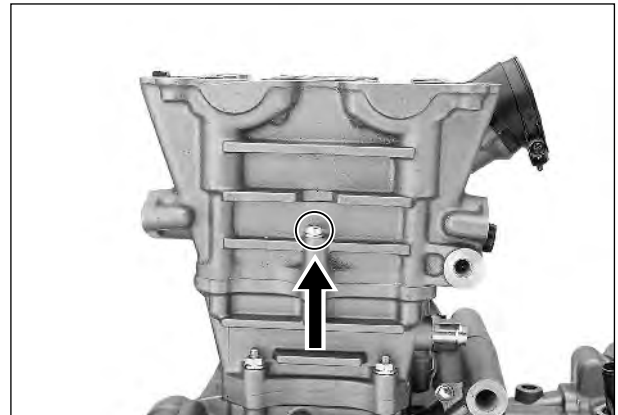

Front Cylinder



Rear Cylinder

⦿ CAMSHAFT ASSEMBLY

- Distinguish the “EX” mark for the exhaust camshaft, the “IN” mark for the intake camshaft.

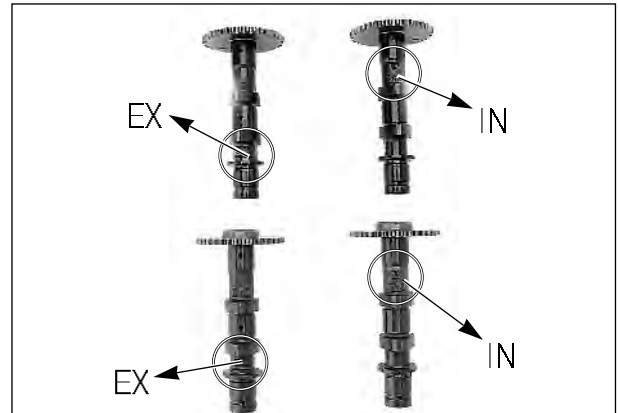

- With pulling up the camshaft drive chain, align the “ | F ” mark of magneto rotor into the punching mark of magneto cover to turn the crankshaft. (Front cylinder)

⚠ CAUTION

When adjusting the rear cylinder, align the “ | R ” mark of magneto rotor into turn counter-clockwise 285° at the position of front cylinder.

⚠ CAUTION

If turn the crankshaft without pulling up the camshaft drive chain, the chain may be fallen off between the crankcase and cam chain drive sprocket.

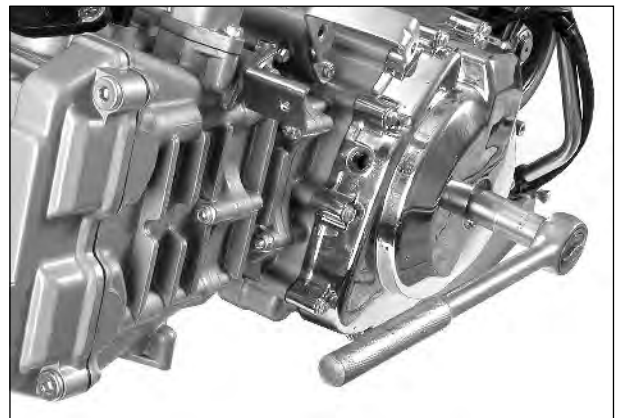

- The front cylinder head install first the exhaust camshaft, following the intake camshaft. The rear cylinder head install first the intake as the cam chain tensioner adjuster exist exhaust side.

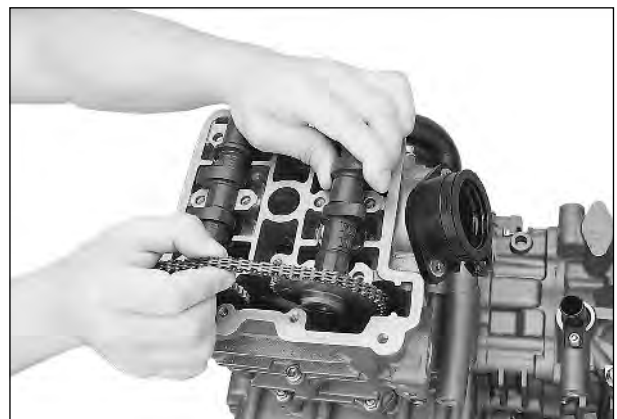

3-55 ENGINE

- The “1F” arrow of exhaust camshaft sprocket should be toward the outside and aligned with the plane of FRONT cylinder head. At that time, the “2” arrow of exhaust camshaft sprocket should be in a vertical position to the plane of cylinder head when exhaust camshaft sprocket was geared into cam chain.

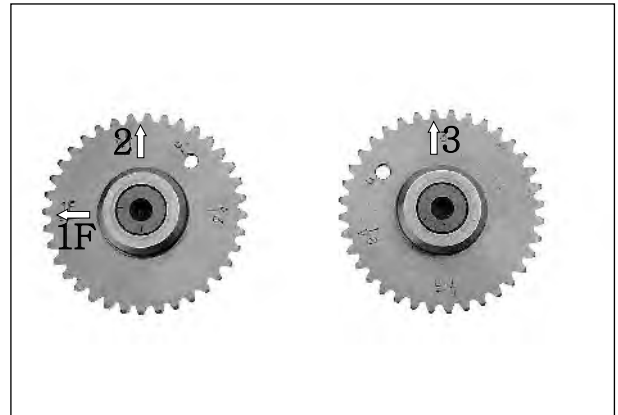

- The “1R” arrow of intake camshaft sprocket should be toward the outside and aligned with the plane of REAR cylinder head. At that time, the “2” arrow of intake camshaft sprocket should be in a vertical position to the plane of cylinder head when the intake camshaft sprocket was geared into the cam chain.

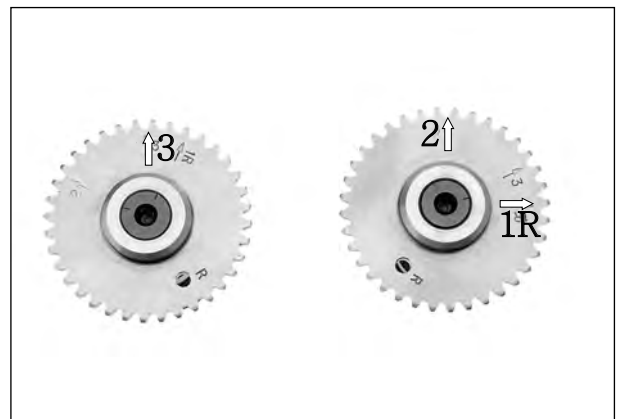

- Gear into the chain at the “3” arrow of intake sprocket that count the 16th of chain roller pin from the roller pin on the “2” arrow of exhaust sprocket to the intake camshaft.

⚠ CAUTION

The REAR cylinder gear into that count the 16th of chain roller pin from the “2” arrow of intake sprocket to the “3” arrow of exhaust sprocket.

- Install the “3” arrow punching mark of intake camshaft sprocket with the surface of cylinder head vertically.

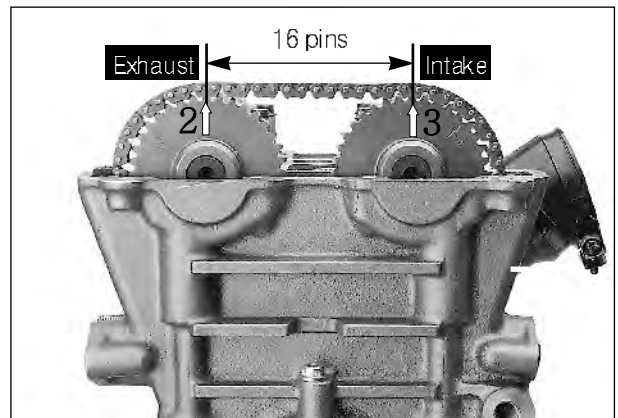

⚠ CAUTION

The cam chain is installed to the all of three sprocket.
 Be sure to lie the crankshaft until the two holder and cam chain tensioner adjuster are installed completely.

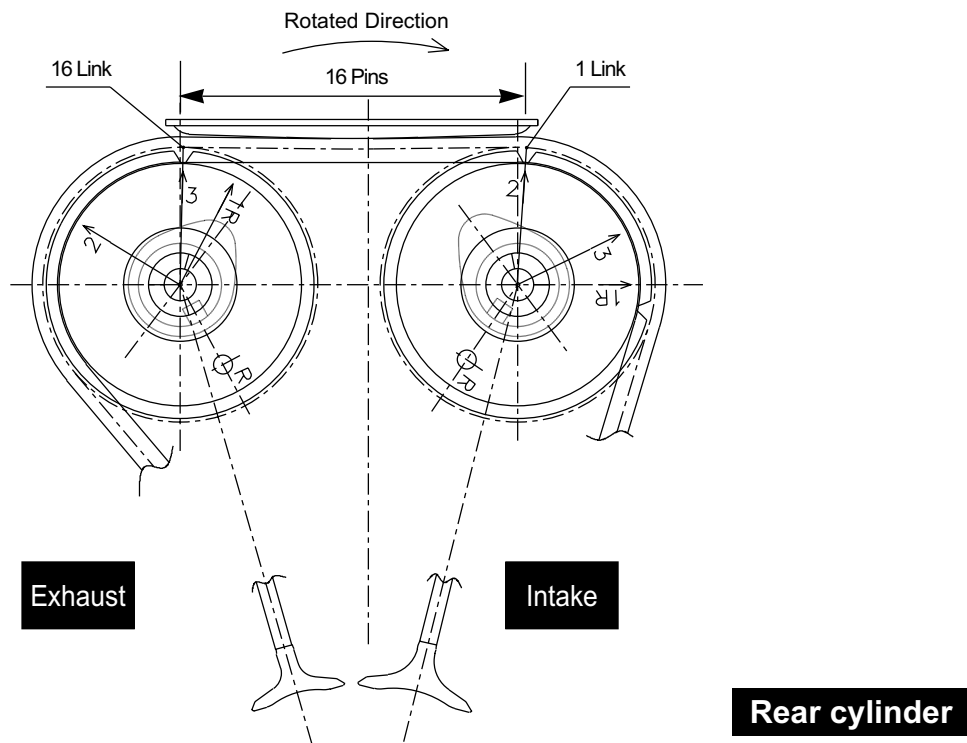
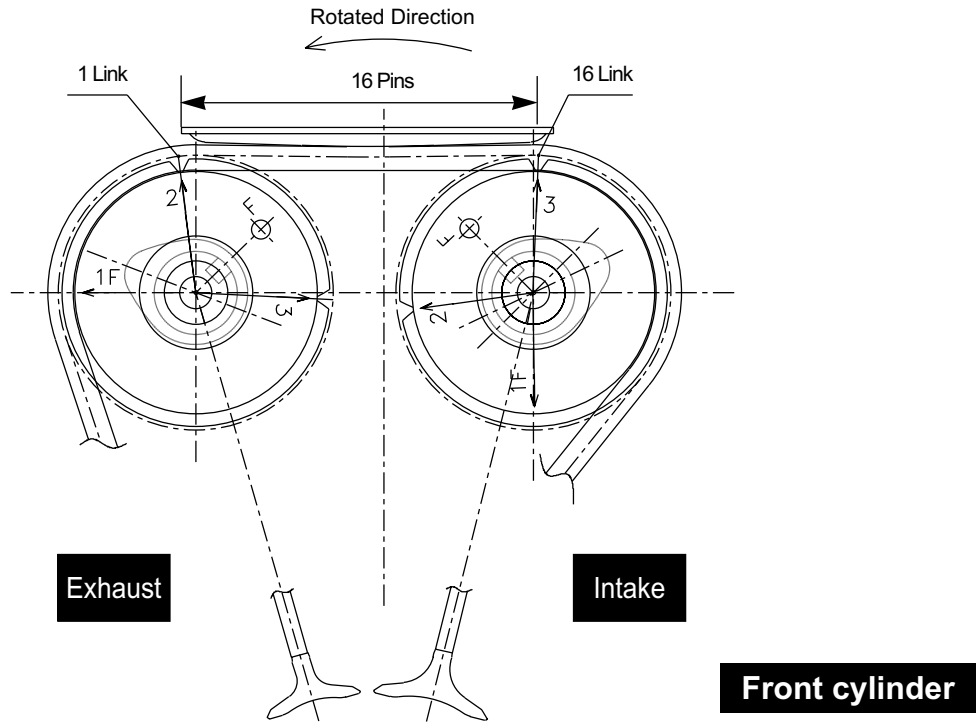

NOTE

The camshaft housing should be installed in the same manner with the front engine.

3-57 ENGINE

- Put the intake or exhaust camshaft housing to the cylinder head upper surface.
- Tighten the camshaft housing bolt with the specified torque diagonally.

CAUTION

The camshaft housing bolt is made of the special material.

This bolt is superior at the degree of hardness more than the different high tension bolt.

Pay special caution that the different type of bolt should not be used.

This bolt head is punched the "9" mark.

Camshaft housing bolt

: 12 N · m (1.2 kgf · m)

- If turn the lock shaft handle in clockwise (↻) direction, the pushrod is inserted in.
Turn the mechanical spring continually until the handle is turned to the end.

- Fix the adjuster into the cylinder block.

- Get out the pushrod for the front to turn the lock shaft handle in counter-clockwise (↻).

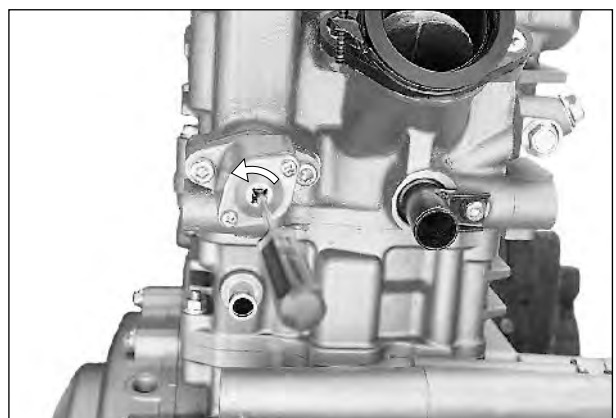
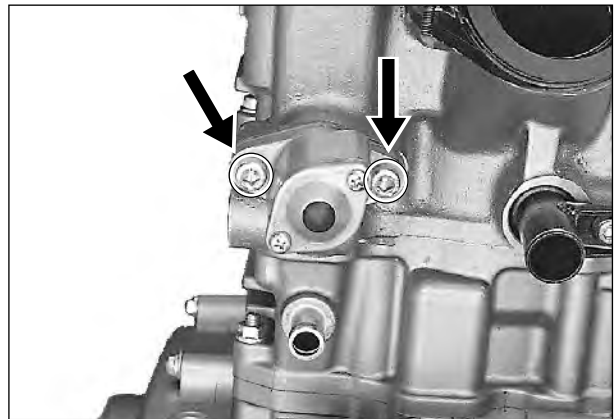
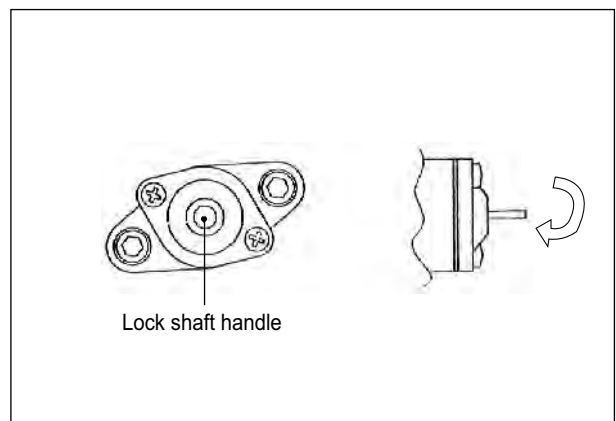

- Turn the crankshaft about 10 times counter-clockwise (↶) on the basis of the magneto rotor.
- If the valve clearance is within standard after measured the valve clearance, begin the next operation. If it is out of standard, adjust the valve clearance within standard limit after disassembled the camshaft and replaced the proper shim.

Valve clearance	Standard
IN.	0.1 ~ 0.2 mm (0.004 ~ 0.008 in)
EX.	0.28 ~ 0.32 mm (0.011 ~ 0.013 in)

- Adjust the valve clearance of rear cylinder with the same manner of the front cylinder.
(Refer to page 2-3)

CAUTION

If you don't turn the crankshaft about 10 times before measured the valve clearance, there is no meaning in valve clearance.

- Apply BOND "1215" to the surface of cylinder head cover packing block.

 BOND "1215"

- Tighten the cylinder head cover bolts with the specified torque.

 Cylinder head cover bolt

: 12 ~ 16 N · m (1.2 ~ 1.6 kgf · m)

⊙ SPARK PLUG

- Install the spark plug. (Refer to page 2-6)

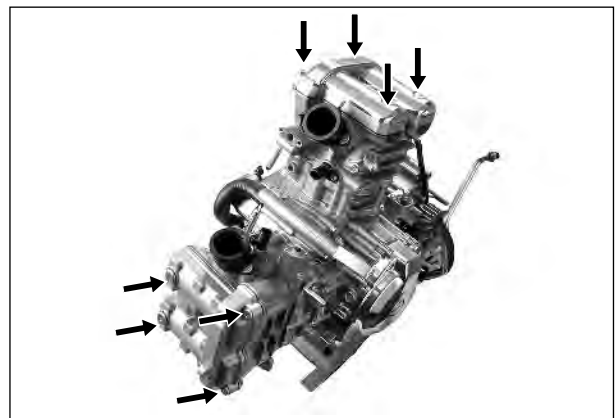
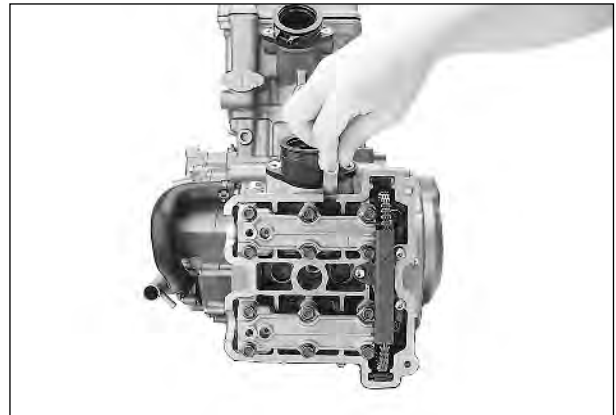

3-59 ENGINE

- Install the rear cylinder head and cylinder with the same manner which installed the front cylinder head and cylinder.

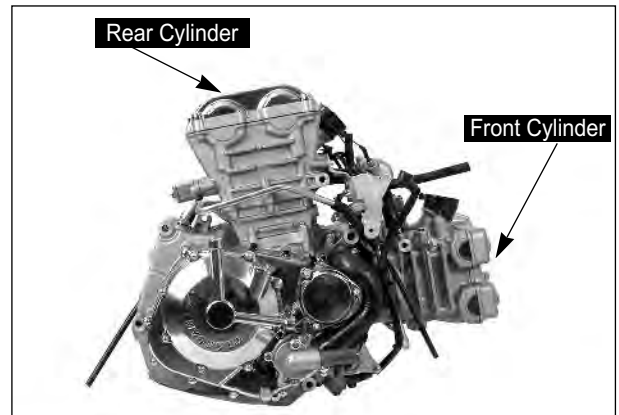

⊙ THERMOSTAT

- Install the thermostat case ① along with the hose ②.

NOTE

Thermostat reassembly

: Refer to page 6-10

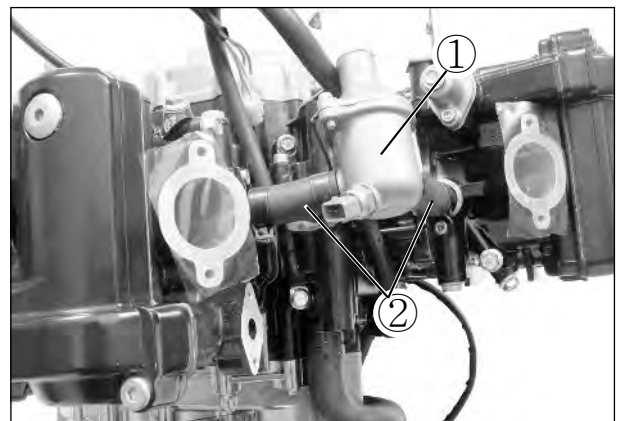

⊙ GEAR POSITION SWITCH

- Install the spring ③ and contact ④.
- Apply **SUPER GREASE "A"** to the O-ring and install the gear position switch.

 **SUPER GREASE "A"**

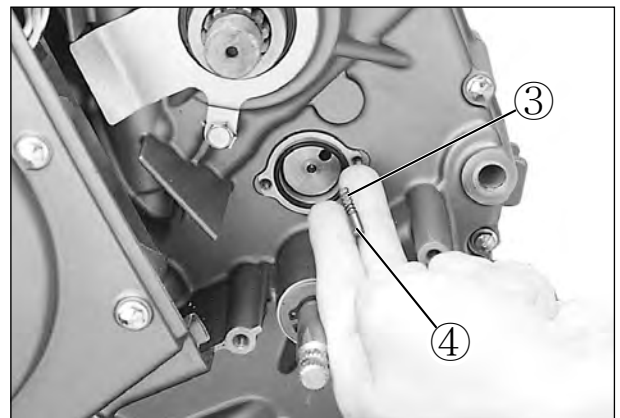

EI SYSTEM DIAGNOSIS

CONTENTS

PRECAUTIONS IN SERVICING	4- 1
EI SYSTEM TECHNICAL FEATURES	4- 5
SELF-DIAGNOSIS FUNCTION	4-10
EI SYSTEM TROUBLESHOOTING	4-19
CUSTOMER COMPLAINT ANALYSIS	4-19
SELF-DIAGNOSTIC PROCEDURES	4-21
SELF-DIAGNOSIS RESET PROCEDURE	4-22
MALFUNCTION CODE AND DEFECTIVE CONDITION	4-23
"0031", "0032", "0037" or "0038"	
OXYGEN SENSOR HEATER CIRCUIT MALFUNCTION &	
"0131", "0132", "0137" or "0138"	
OXYGEN SENSOR CIRCUIT MALFUNCTION	4-27
"0107" or "0108" IAP SENSOR CIRCUIT MALFUNCTION	4-29
"0112" or "0113" IAT SENSOR CIRCUIT MALFUNCTION	4-31
"0117" or "0118" WT SENSOR CIRCUIT MALFUNCTION	4-33
"0122" or "0123" TP SENSOR CIRCUIT MALFUNCTION	4-35
"0201" or "0202" FUEL INJECTOR CIRCUIT MALFUNCTION	4-38
"0230" or "0232" FUEL PUMP RELAY CIRCUIT MALFUNCTION	4-40
"0336" or "0337" PICK-UP COIL CIRCUIT MALFUNCTION	4-41
"0351" or "0352" IGNITION COIL MALFUNCTION	4-43
"0444" or "0445" PURGE CONTROL VALVE CIRCUIT	
MALFUNCTION (California model only)	4-44
"0505" ISC SOLENOID RANGE ABNORMAL	4-46
"0562" or "0563" BATTERY VOLTAGE MALFUNCTION	4-47
"0650" "FI" CHECK LAMP CIRCUIT MALFUNCTION	4-48
"0850" GP or CLUTCH LEVER SWITCH CIRCUIT MALFUNCTION ...	4-49
SENSORS	4-51

PRECAUTIONS IN SERVICING

When handling the component parts or servicing the EI system, observe the following points for the safety of the system.

⦿ ELECTRICAL PARTS

▣ CONNECTOR / COUPLER

- When connecting a connector, be sure to push it in until a click is felt.
- With a lock type coupler, be sure to release the lock when disconnecting, and push it in fully till the works when connecting it.
- When disconnecting the coupler, be sure to hold the coupler body and do not pull the lead wires.
- Inspect each terminal on the connector / coupler for looseness or bending.
- Inspect each terminal for corrosion and contamination.
The terminals must be clean and free of any foreign material which could impede proper terminal contact.
- Inspect each lead wire circuit for poor connection by shaking it by hand lightly. If any abnormal condition is found, repair or replace.
- When taking measurements at electrical connectors using a tester probe, be sure to insert the probe from the wire harness side (backside) of the connector / coupler.

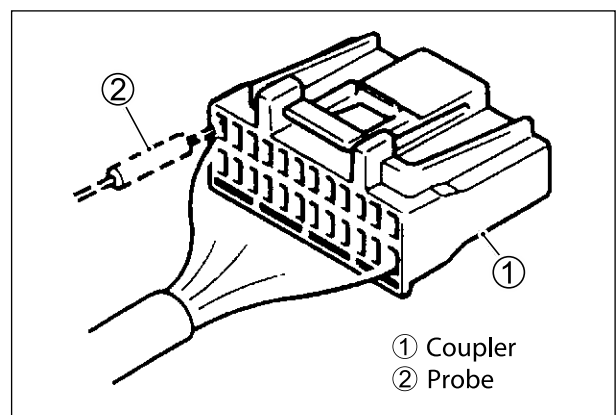
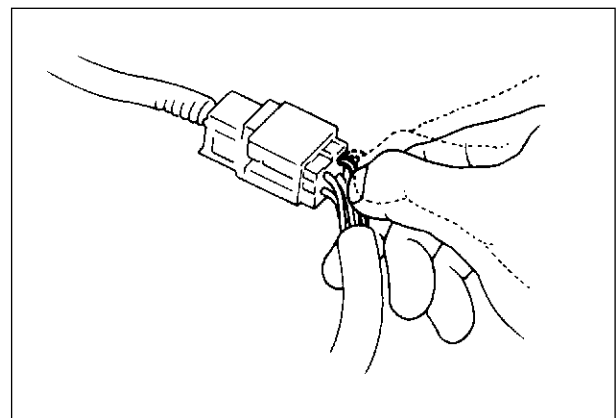
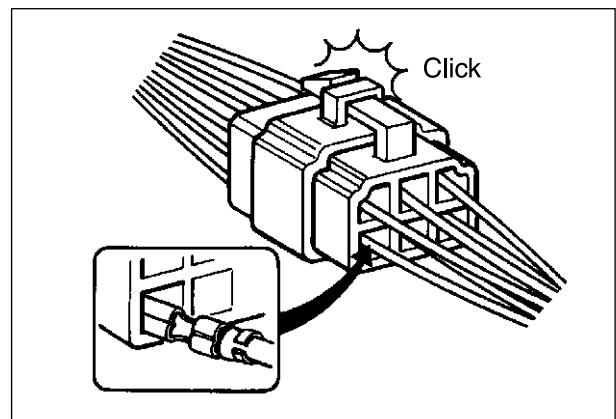
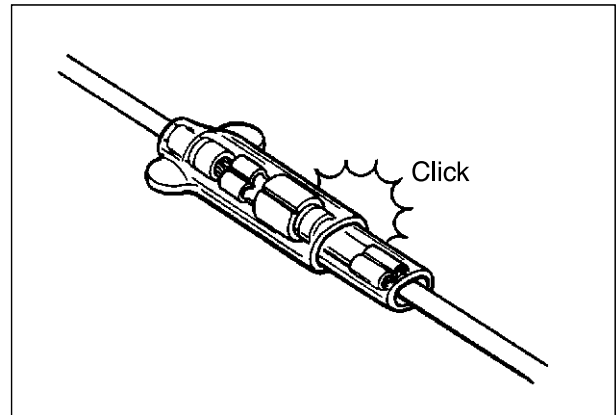

- When connecting meter probe from the terminal side of the coupler (connection from harness side not being possible), use extra care not to force and cause the male terminal to bend or the female terminal to open. Connect the probe as shown to avoid opening of female terminal. Never push in the probe where male terminal is supposed to fit.
- Check the male connector for bend and female connector for excessive opening. Also check the coupler for locking (looseness), corrosion, dust, etc.

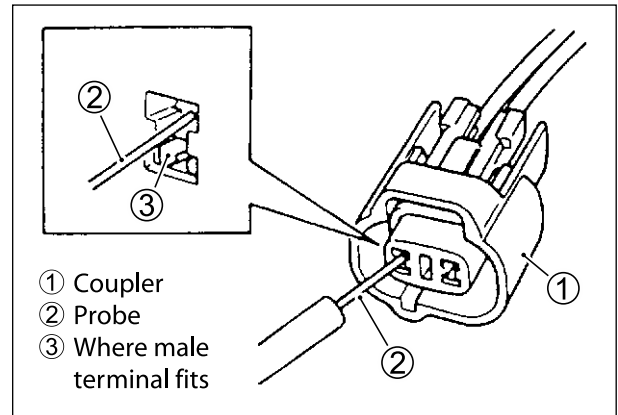

⦿ FUSE

- When a fuse blows, always investigate the cause to correct it and then replace the fuse.
- Do not use a fuse of a different capacity.
- Do not use wire or any other substitute for the fuse.

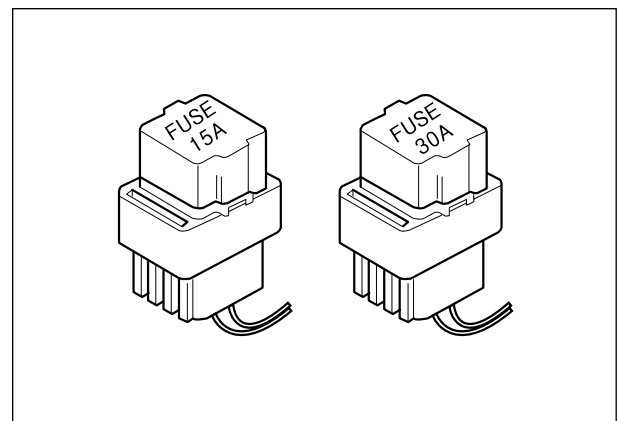

⦿ ECU / VARIOUS SENSORS

- Since each component is a high-precision part, great care should be taken not to apply any sharp impacts during removal and installation.

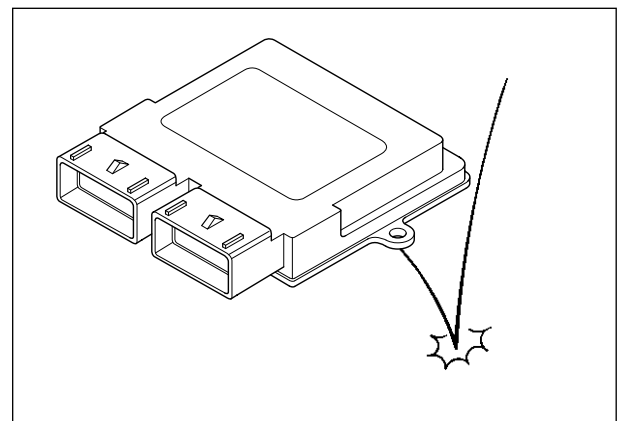

- Be careful not to touch the electrical terminals of the ECU. The static electricity from your body may damage this part.

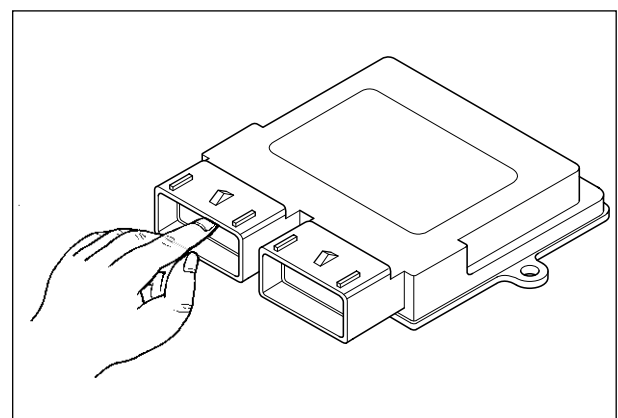

4-3 EI SYSTEM DIAGNOSIS

- When disconnecting and connecting the ECU, make sure to turn "OFF" the ignition switch, or electronic parts may get damaged.

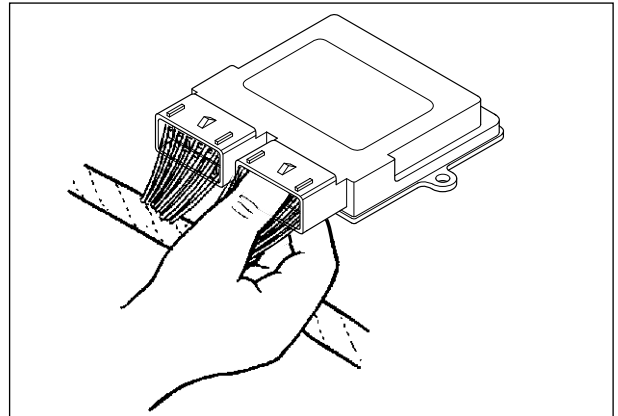

- Battery connection in reverse polarity is strictly prohibited. Such a wrong connection will damage the components of the EI system instantly when reverse power is applied.

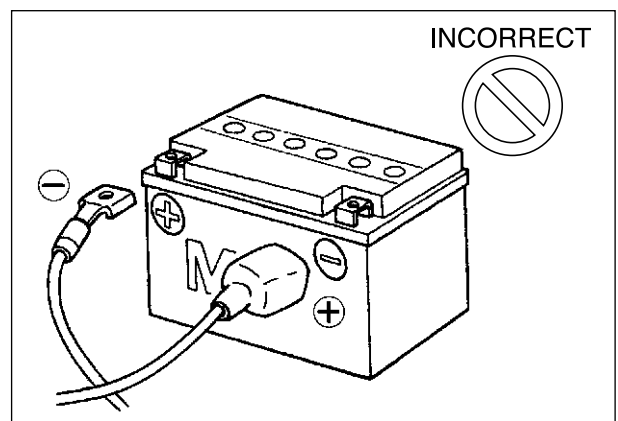

- Removing any battery terminal of a running engine is strictly prohibited. The moment such removal is made, damaging counter electromotive force will be applied to the ECU which may result in serious damage.

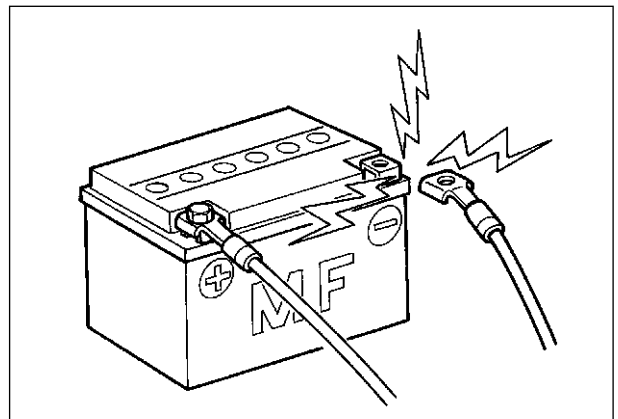

- Before measuring voltage at each terminal, check to make sure that battery voltage is 11 V or higher. Terminal voltage check at low battery voltage will lead to erroneous diagnosis.

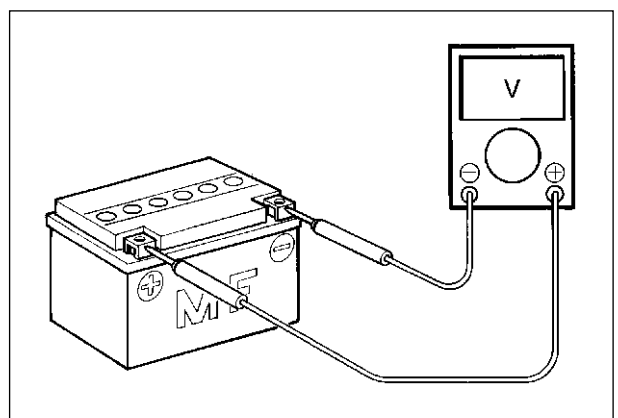

- Never connect an ohmmeter to the ECU with its coupler connected. If attempted, damage to the ECU or sensors may result.
- Be sure to use a specified voltmeter / ohmmeter. Otherwise, accurate measurements may not be obtained and personal injury may result.

⦿ USING TESTERS

- Use well-charged batteries in the tester.
- Be sure to set the tester to the correct testing range.

▣ USING THE TESTER

- Incorrectly connecting the \oplus and \ominus probes may cause the inside of the tester to burnout.
- If the voltage and current are not known, make measurements using the highest range.
- After using the tester, turn the power off.

EI SYSTEM TECHNICAL FEATURES

⊙ EI SYSTEM'S CONTROL DIAGRAM

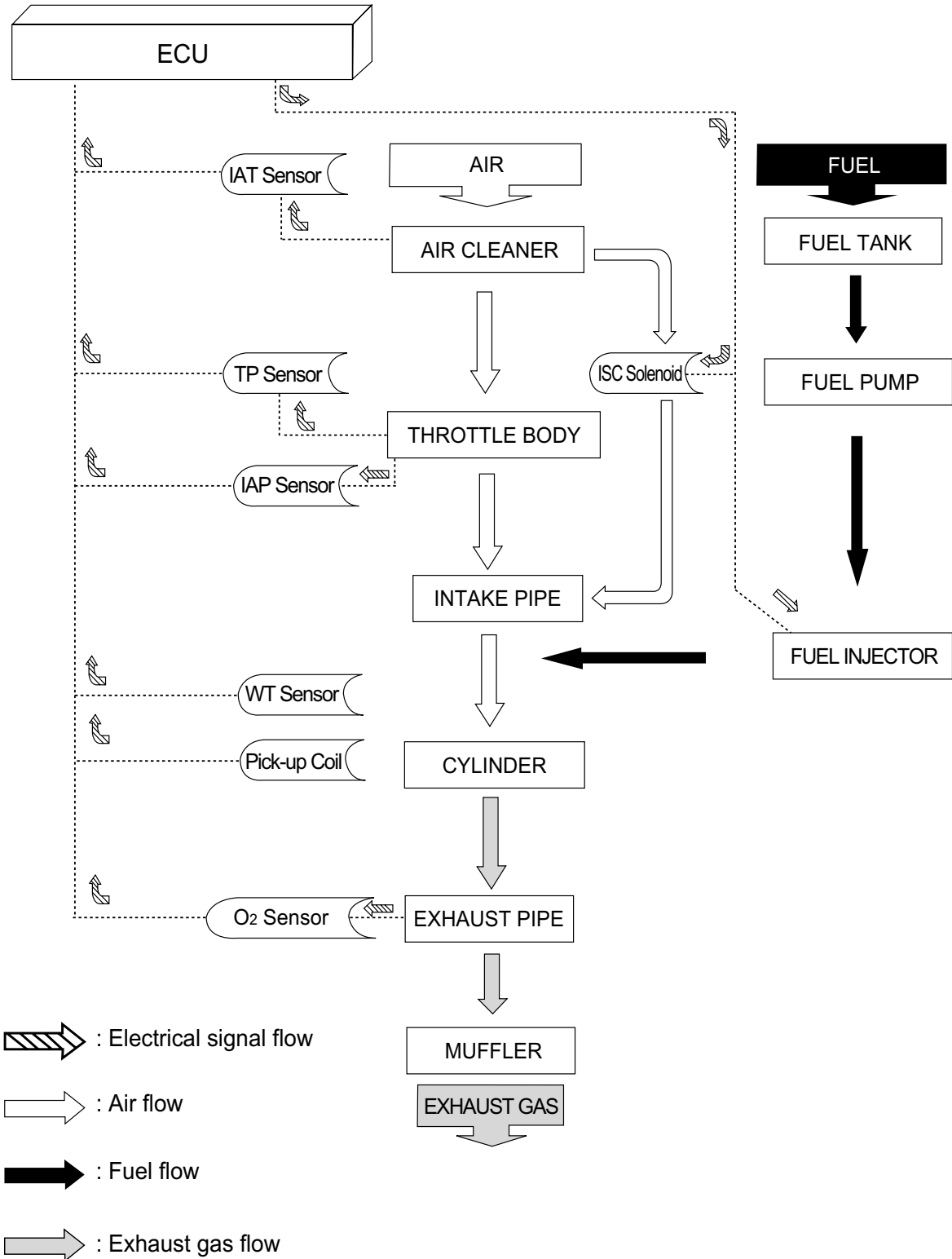

◎ INJECTION TIME (INJECTION VOLUME)

The factors to determine the injection time include the basic fuel injection time, which is calculated on the basis of intake air pressure, engine speed and throttle opening angle, and various compensations.

These compensations are determined according to the signals from various sensors that detect the engine and driving conditions.

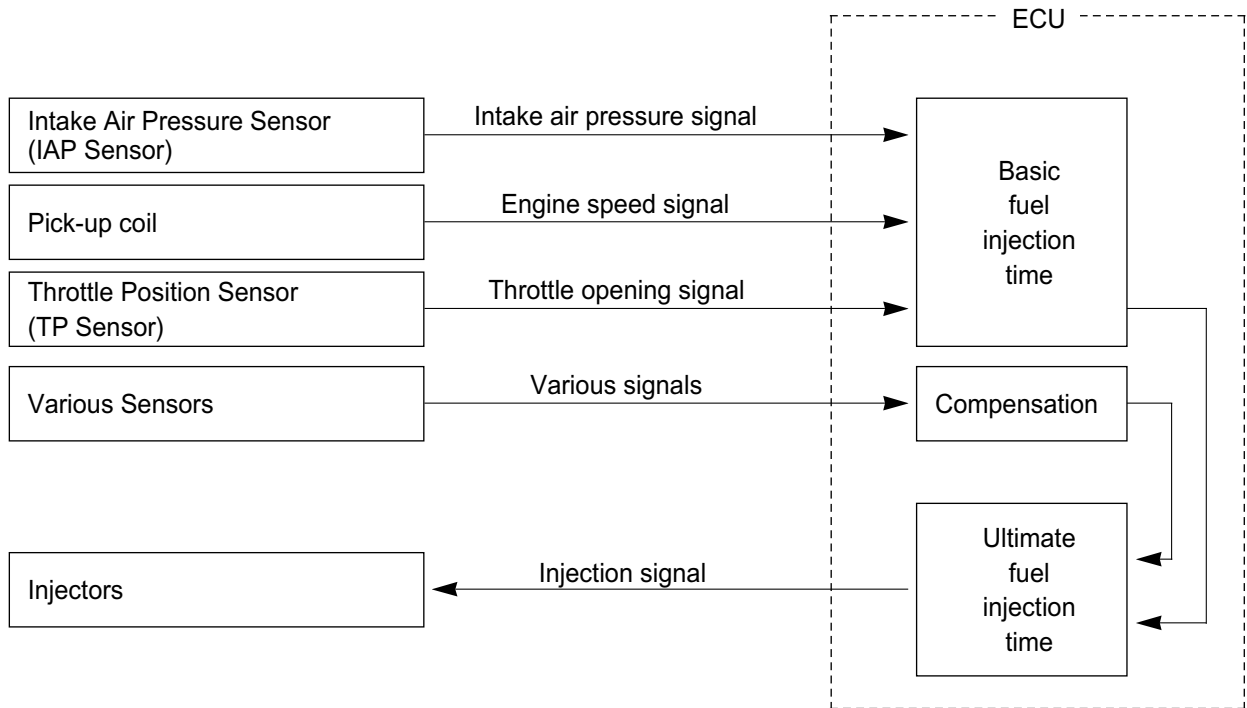

⊙ COMPENSATION OF INJECTION TIME (VOLUME)

The following different signals are output from the respective sensors for compensation of the fuel injection time (volume).

SIGNAL	DESCRIPTION
WATER COOLANT TEMPERATURE SENSOR SIGNAL	When engine coolant temperature is low, injection time (volume) is increased.
INTAKE AIR TEMPERATURE SENSOR SIGNAL	When intake air temperature is low, injection time (volume) is increased.
BATTERY VOLTAGE SIGNAL	ECU operates on the battery voltage and at the same time, it monitors the voltage signal for compensation of the fuel injection time (volume). A longer injection time is needed to adjust injection volume in the case of low voltage.
ENGINE RPM SIGNAL	At high speed, the injection time (volume) is increased.
STARTING SIGNAL	When starting engine, additional fuel is injected during cranking engine.
ACCELERATION SIGNAL / DECELERATION SIGNAL	During acceleration, the fuel injection time (volume) is increased in accordance with the throttle opening speed and engine rpm. During deceleration, the fuel injection time (volume) is decreased.

⊙ INJECTION STOP CONTROL

SIGNAL	DESCRIPTION
ROLL OVER SWITCH SIGNAL (FUEL CUT-OFF)	When the motorcycle rolls over, the roll over switch sends a signal to the ECU. Then, this signal cuts OFF current supplied to the fuel pump, fuel injector and ignition coil.
OVER-REV. LIMITER SIGNAL	The fuel injectors stop operation when engine rpm reaches rev. limit rpm.

◎ EI SYSTEM PARTS LOCATION

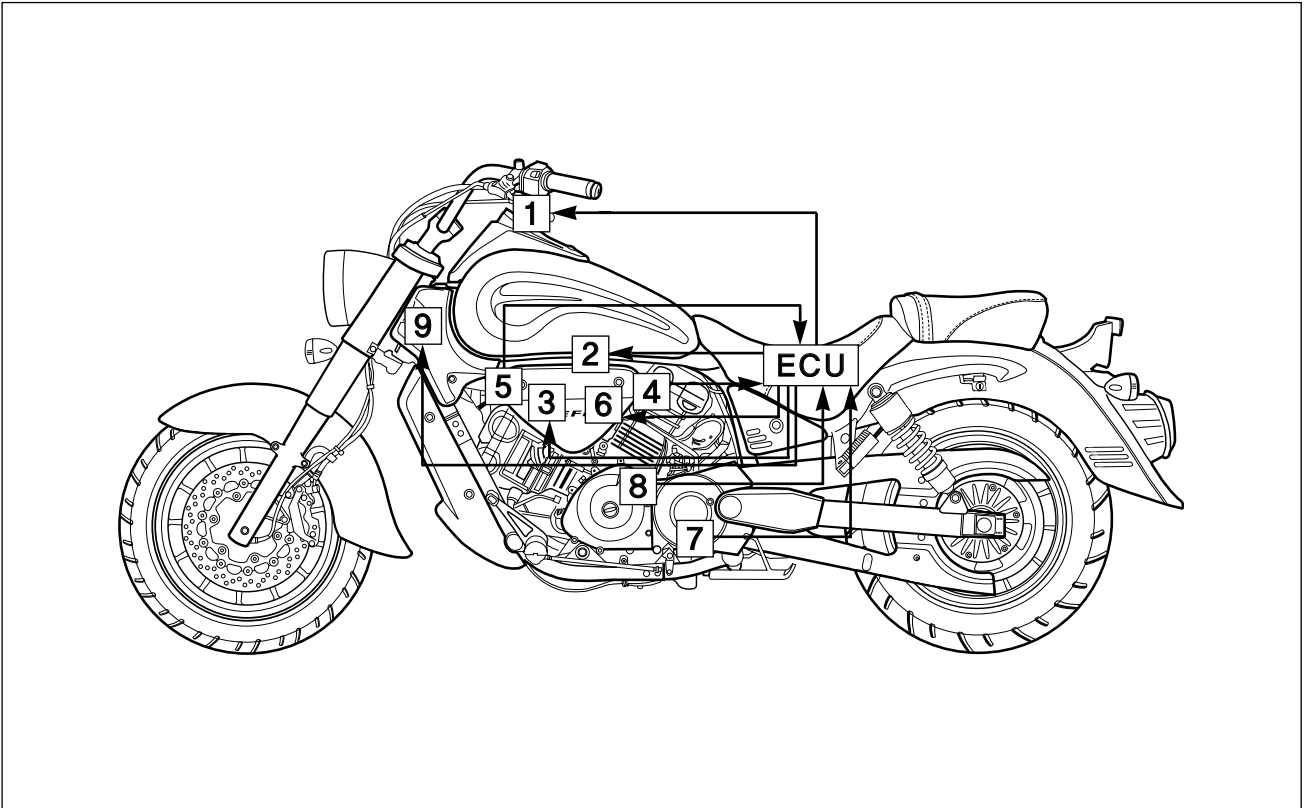

- | | |
|-----------------------|-----------------------|
| ① Speedometer | ⑥ Fuel injector, NO.2 |
| ② Fuel pump relay | ⑦ GP switch |
| ③ Fuel injector, NO.1 | ⑧ Pick-up coil |
| ④ TP sensor | ⑨ Ignition coil, NO.1 |
| ⑤ IAT sensor | |

4-9 EI SYSTEM DIAGNOSIS

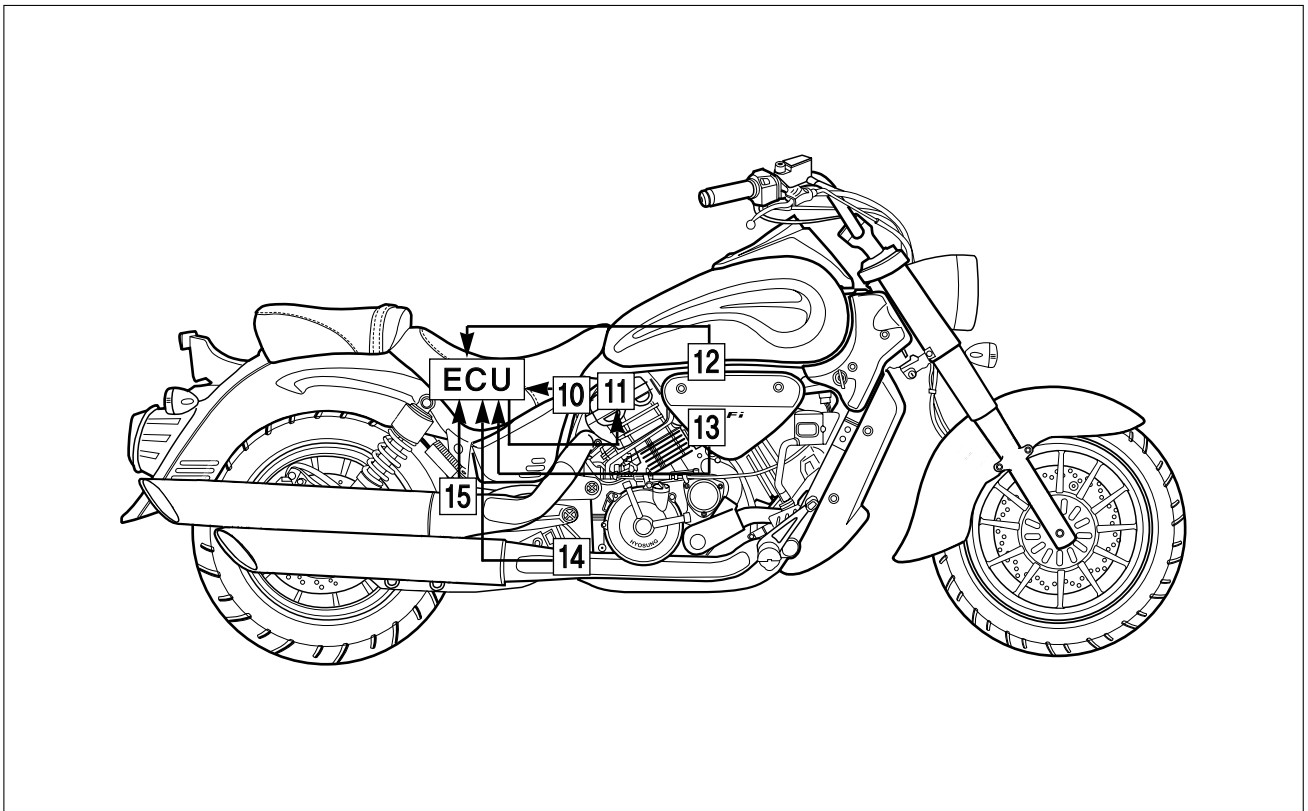

- ⑩ RO switch
- ⑪ Ignition coil, NO.2
- ⑫ IAP sensor

- ⑬ WT sensor
- ⑭ Oxygen sensor, NO.1
- ⑮ Oxygen sensor, NO.2

SELF-DIAGNOSIS FUNCTION

The self-diagnosis function is incorporated in the ECU.

The function has two modes, "USER MODE" and "DEALER MODE".

The user can only be notified by the "FI" check lamp "  " ①.

To check the function of the individual EI system devices, the dealer mode is prepared.

In this check, the special tool or additional movement is necessary to read the code of the malfunction items.

⊙ USER MODE

The "FI" check lamp "  " ① comes on when the ignition switch is set to "ON" position with the engine stopped as a test of injection system operation.

As soon as the engine starts, this lamp should go out.

If the fuel injection system fails, the red "FI" check lamp "  " ① does not come on when the ignition switch is set to "ON" position with the engine stopped or fail to go out after the engine start.

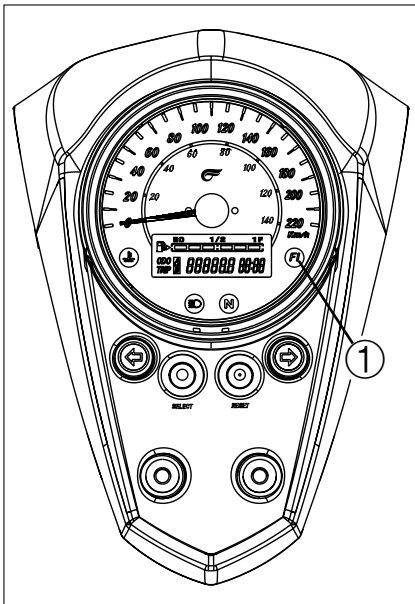

⦿ DEALER MODE

The defective function is memorized in the ECU.

The memorized malfunction code is displayed on the LCD (DISPLAY) panel (A) or with blinks signal of the "FI" check lamp "F" (B).

Malfunction means that the ECU does not receive signal from the devices or fault signal received.

These affected devices are indicated in the code form on the LCD (DISPLAY) panel (A) or displayed with blinks signal of the "FI" check lamp "F" (B).

■ A. LCD (DISPLAY) PANEL

To confirm the memorized malfunction code :

1. Remove the front seat.
2. Connect the special tool to the dealer mode coupler at the wiring harness, and the ignition switch is set to "ON" position.

 **Mode select switch : 09900-27000**

3. Turn the special tool's switch "ON" position.
4. Push the select switch (C) (in the normal mode) for 5 seconds.

NOTE

This time, if not connect the special tool, the clock indicates the "cHE" letters then disappear.

5. The memorized malfunction code is displayed on the LCD (DISPLAY) panel (A).
The malfunction code is indicated in the code form.
6. Start the engine and repeat the above procedure.
7. Check the malfunction code to determine the malfunction part.
8. Push the select switch (C) (in the malfunction code mode) for 0.6 ~ 1 seconds, then the LCD (DISPLAY) panel (A) is displayed the CLOCK.

NOTE

The malfunction code of the LCD (DISPLAY) panel (A) is displayed the current code(s).

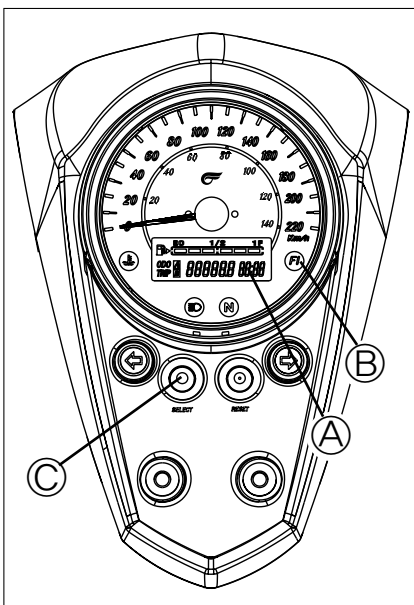

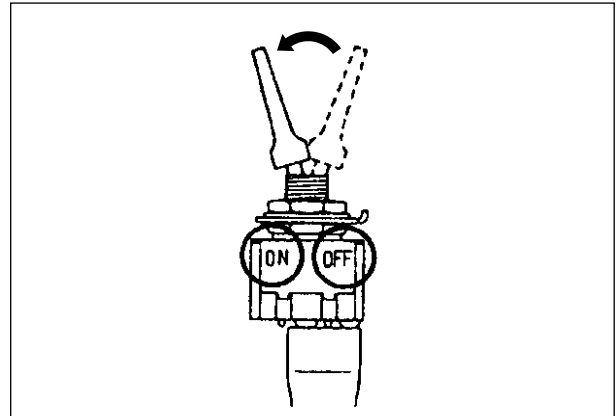
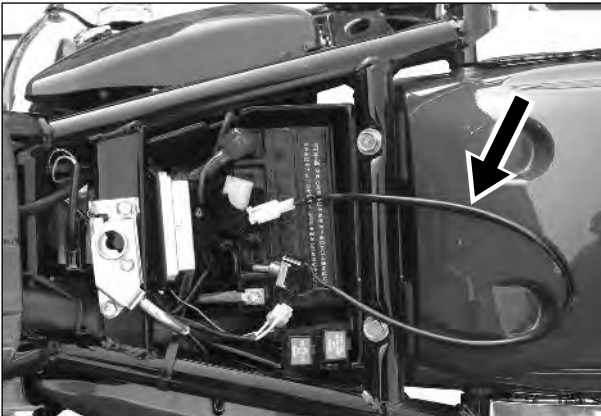

⚠ CAUTION

- ❖ Confirm the malfunction code after turn the ignition switch “ON” position and after starting the engine in twice.
- ❖ The dealer mode coupler is located under the front seat.

CLASSIFICATION	MALFUNCTION	LCD (DISPLAY) INDICATION [Ⓐ]	“FI” CHECK LAMP INDICATION [Ⓑ]	INDICATION MODE
IGNITION SWITCH “ON” POSTION	“NO”	noEr	“FI” check lamp comes on continually.	“noEr” letters → CLOCK
	“YES”	**** code is indicated in chronological order.	“FI” check lamp goes off.	For each 2 sec., code is indicated.
ENGINE RUNNING	“NO”	noEr	“FI” check lamp goes off.	“noEr” letters → CLOCK
	“YES”	**** code is indicated in chronological order.	“FI” check lamp comes on continually.	For each 2 sec., code is indicated.

■ B. “FI” CHECK LAMP

To confirm the memorized malfunction code :

1. Turn the ignition switch alternately, “ON” and “OFF” position, for 2 seconds by three times.

⚠ CAUTION

Take special care when operating above procedure.

If the ignition switch is turned alternately, “ON” and “OFF” position, for 2 seconds by five times, the ECU is initialized.



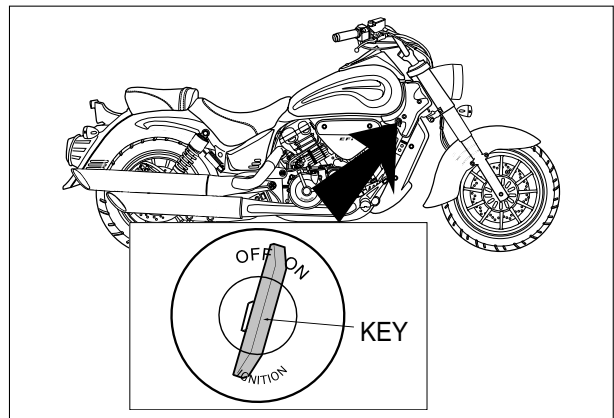
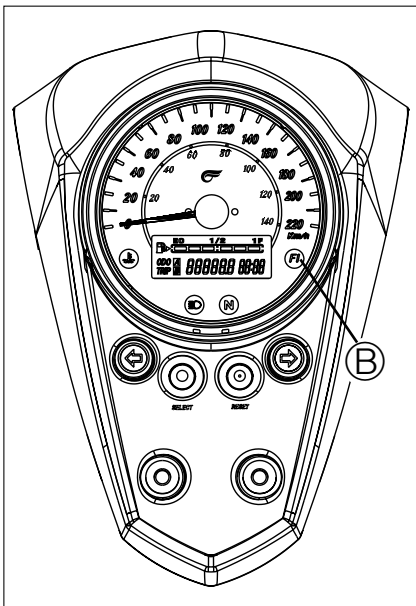

2. The memorized malfunction code is displayed with blinks signal of the “FI” check lamp “**F**” **B**.
3. Check the malfunction code to determine the malfunction part.

NOTE

The malfunction code of the “FI” check lamp is displayed both the current code(s) and history code(s).

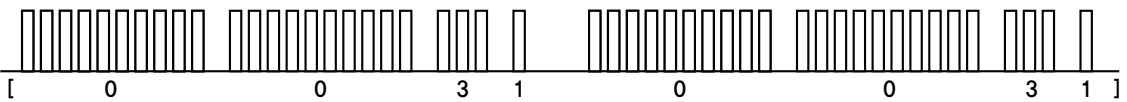
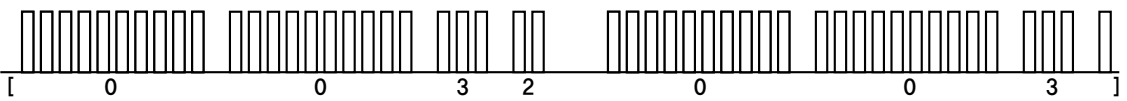
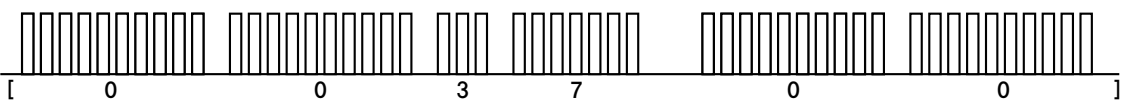
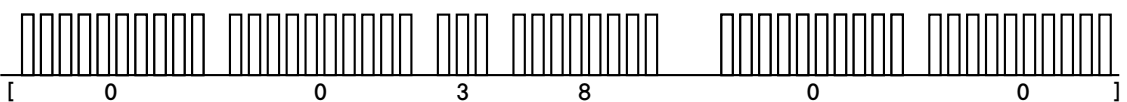

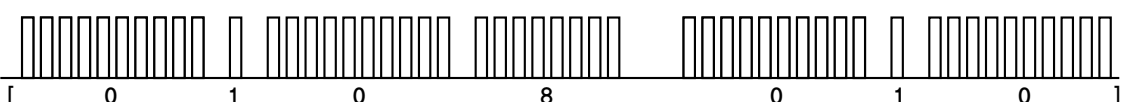
MALFUNCTION	“FI” CHECK LAMP INDICATION B
“NO”	“FI” check lamp goes off.
“YES”	Malfunction code is blinked in chronological order.

A CODE	B CODE	
	MALFUNCTION PART	REMARKS
0031	 <p>[0 0 3 1 0 0 3 1]</p>	NO.1 O ₂ S heater Circuit Low Voltage For NO.1 cylinder
0032	 <p>[0 0 3 2 0 0 3 1]</p>	NO.1 O ₂ S heater Circuit High Voltage For NO.1 cylinder
0037	 <p>[0 0 3 7 0 0 0 0]</p>	NO.2 O ₂ S heater Circuit Low Voltage For NO.2 cylinder
0038	 <p>[0 0 3 8 0 0 0 0]</p>	NO.2 O ₂ S heater Circuit High Voltage For NO.2 cylinder
0107	 <p>[0 1 0 7 0 1 0 0]</p>	IAPS Circuit Low Voltage or Open
0108	 <p>[0 1 0 8 0 1 0 0]</p>	IAPS Circuit High Voltage
0112	 <p>[0 1 1 2 0 1 1 2 0 1 1 2]</p>	IATS Circuit Low Voltage
0113	 <p>[0 1 1 3 0 1 1 3 0 1 1 3]</p>	IATS Circuit High Voltage or Open

※ A CODE : For LCD (DISPLAY) indication









B CODE : For "FI" check lamp indication

4-15 EI SYSTEM DIAGNOSIS

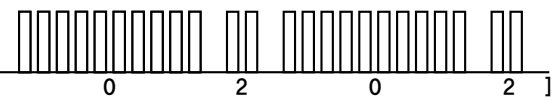
A CODE	B CODE	
	MALFUNCTION PART	REMARKS
0117	 [0 1 1 7 0 1 1 7]	
	WTS Circuit Low Voltage	
0118	 [0 1 1 8 0 1 1 8]	
	WTS Circuit High Voltage or Open	
0122	 [0 1 2 2 0 1 2 2 0 1 2]	
	TPS Circuit Low Voltage or Open	
0123	 [0 1 2 3 0 1 2 3 0 1]	
	TPS Circuit High Voltage	
0131	 [0 1 3 1 0 1 3 1 0 1 3]	
	NO.1 O ₂ S Circuit Low Voltage	For NO.1 cylinder
0132	 [0 1 3 2 0 1 3 2 0 1]	
	NO.1 O ₂ S Circuit High Voltage	For NO.1 cylinder
0137	 [0 1 3 7 0 1 3 7]	
	NO.2 O ₂ S Circuit Low Voltage	For NO.2 cylinder
0138	 [0 1 3 8 0 1 3 8]	
	NO.2 O ₂ S Circuit High Voltage	For NO.2 cylinder

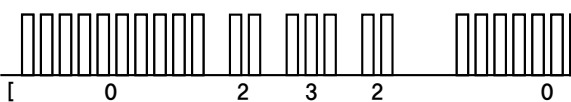
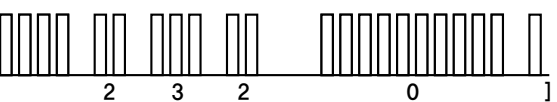
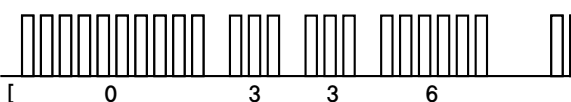
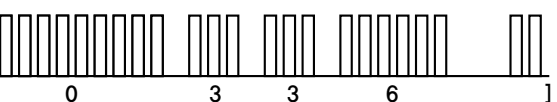
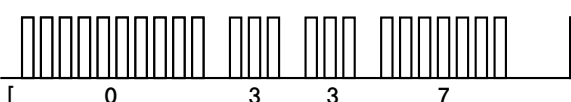
※ A CODE : For LCD (DISPLAY) indication

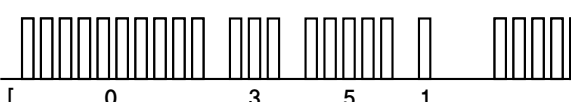
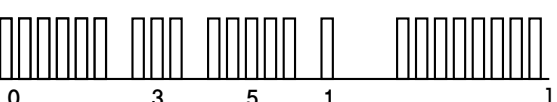
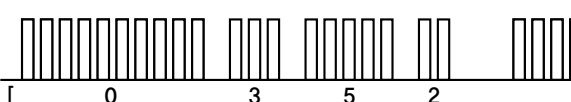
B CODE : For "FI" check lamp indication

A CODE	B CODE	
	MALFUNCTION PART	REMARKS
0201	 [0 2 0 1]	 [0 2 0 1]
	NO.1 Fuel injector Circuit Malfunction	For NO.1 cylinder
0202	 [0 2 0 2]	 [0 2 0 2]
	NO.2 Fuel injector Circuit Malfunction	For NO.2 cylinder
0230	 [0 2 3 0]	 [0 2 3]
	Fuel pump relay Circuit Low Voltage or Open	
0232	 [0 2 3 2 0 2 3 2 0]	 [0 2 3 2 0]
	Fuel pump relay Circuit High Voltage	
0336	 [0 3 3 6]	 [0 3 3 6]
	Pick-up coil Noisy Signal	
0337	 [0 3 3 7]	 [0 3 3 7]
	Pick-up coil No Signal	
0351	 [0 3 5 1]	 [0 3 5 1]
	NO.1 IG coil Malfunction	For NO.1 cylinder
0352	 [0 3 5 2]	 [0 3 5 2]
	NO.2 IG coil Malfunction	For NO.2 cylinder

※ A CODE : For LCD (DISPLAY) indication

B CODE : For "FI" check lamp indication

4-17 EI SYSTEM DIAGNOSIS

A CODE	B CODE	
	MALFUNCTION PART	REMARKS
0444	 [0 4 4 4]	 [0 4 4 4]
	PV Circuit Open	California model only
0445	 [0 4 4 5]	 [0 4 4 5]
	PV Circuit Shorted	California model only
0505	 [0 5 0 5]	 [0 5 0 5]
	ISC Error	
0562	 [0 5 6 2]	 [0 5 6 2]
	Battery Voltage Low	
0563	 [0 5 6 3]	 [0 5 6 3]
	Battery Voltage High	
0650	 [0 6 5 0]	 [0 6 0]
	"FI" check lamp Circuit Malfunction	
0850	 [0 8 5 0]	 [0 8]
	GP or Clutch lever Switch Circuit Malfunction	

※ A CODE : For LCD (DISPLAY) indication

B CODE : For "FI" check lamp indication

■ LCD (DISPLAY) INDICATION

In the LCD (DISPLAY) panel ①, the malfunction code is indicated in chronological order.

■ “FI” CHECK LAMP INDICATION

In the “FI” check lamp “**FI**” ②, the malfunction code is blinked in chronological order.

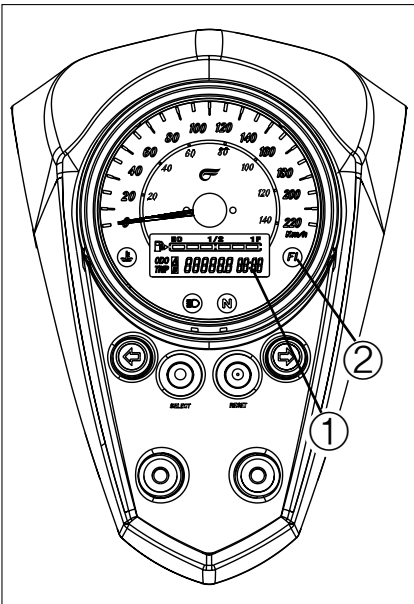

EI SYSTEM TROUBLESHOOTING

CUSTOMER COMPLAINT ANALYSIS

Record details of the problem (failure, complaint) and how it occurred as described by the customer. For this purpose, use of such an inspection form will facilitate collecting information to the point required for proper analysis and diagnosis.

■ EXAMPLE : CUSTOMER PROBLEM INSPECTION FORM

User name :	Model :	VIN :	
Date of issue :	Date Reg. :	Date of problem :	Mileage :

"FI" Check lamp	<input type="checkbox"/> Always ON <input type="checkbox"/> Sometimes ON <input type="checkbox"/> Always OFF <input type="checkbox"/> Good condition
Malfunction display / code (LCD panel) or Blinks signal ("FI" check lamp)	<input type="checkbox"/> No code <input type="checkbox"/> Malfunction code ()

PROBLEM SYMPTOMS	
<input type="checkbox"/> Difficult Starting <input type="checkbox"/> No cranking <input type="checkbox"/> No initial combustion <input type="checkbox"/> No combustion <input type="checkbox"/> Poor starting at (<input type="checkbox"/> cold <input type="checkbox"/> warm <input type="checkbox"/> always) <input type="checkbox"/> Other _____	<input type="checkbox"/> Poor Driveability <input type="checkbox"/> Hesitation on acceleration <input type="checkbox"/> Back fire / <input type="checkbox"/> After fire <input type="checkbox"/> Lack of power <input type="checkbox"/> Surging <input type="checkbox"/> Abnormal knocking <input type="checkbox"/> Engine rpm jumps briefly <input type="checkbox"/> Other _____
<input type="checkbox"/> Poor Idling <input type="checkbox"/> Poor fast Idle <input type="checkbox"/> Abnormal idling speed (<input type="checkbox"/> High <input type="checkbox"/> Low) (rpm) <input type="checkbox"/> Unstable <input type="checkbox"/> Hunting (rpm. to rpm) <input type="checkbox"/> Other _____	<input type="checkbox"/> Engine Stall when <input type="checkbox"/> Immediately after start <input type="checkbox"/> Throttle valve is opened <input type="checkbox"/> Throttle valve is closed <input type="checkbox"/> Load is applied <input type="checkbox"/> Other _____
<input type="checkbox"/> OTHERS :	

MOTORCYCLE / ENVIRONMENTAL CONDITION WHEN PROBLEM OCCURS	
Environmental condition	
Weather	<input type="checkbox"/> Fair <input type="checkbox"/> Cloudy <input type="checkbox"/> Rain <input type="checkbox"/> Snow <input type="checkbox"/> Always <input type="checkbox"/> Other
Temperature	<input type="checkbox"/> Hot <input type="checkbox"/> Warm <input type="checkbox"/> Cool <input type="checkbox"/> Cold (°F / °C) <input type="checkbox"/> Always
Frequency	<input type="checkbox"/> Always <input type="checkbox"/> Sometimes (times / day, month) <input type="checkbox"/> Only once <input type="checkbox"/> Under certain condition
Road	<input type="checkbox"/> Urban <input type="checkbox"/> Suburb <input type="checkbox"/> Highway <input type="checkbox"/> Mountainous (<input type="checkbox"/> Uphill <input type="checkbox"/> Downhill) <input type="checkbox"/> Tarmacadam <input type="checkbox"/> Gravel <input type="checkbox"/> Other
Motorcycle condition	
Engine condition	<input type="checkbox"/> Cold <input type="checkbox"/> Warming up phase <input type="checkbox"/> Warmed up <input type="checkbox"/> Always <input type="checkbox"/> Other at starting <input type="checkbox"/> Immediately after start <input type="checkbox"/> Racing without load <input type="checkbox"/> Engine speed (rpm)
Motorcycle condition	During driving : <input type="checkbox"/> Constant speed <input type="checkbox"/> Accelerating <input type="checkbox"/> Decelerating <input type="checkbox"/> Right hand corner <input type="checkbox"/> Left hand corner <input type="checkbox"/> At stop <input type="checkbox"/> Motorcycle speed when problem occurs (km/h, Mile/h) <input type="checkbox"/> Other _____

NOTE

***The above form is a standard sample.
If should be modified according to conditions characteristic of each market.***

SELF-DIAGNOSTIC PROCEDURES

Don't disconnect couplers from ECU, battery cable from battery, ECU ground wire harness from engine or main fuse before confirming malfunction code (self-diagnostic trouble code) stored in memory.

The memorized malfunction code is displayed on the LCD (DISPLAY) panel **A** or displayed with blinks signal of the "FI" check lamp " **F** " **B**.

To check malfunction code, read SELF-DIAGNOSIS FUNCTION "DEALER MODE" (Refer to page 4-11 ~ 18) carefully to have good understanding as to what functions are available and how to use it.

Be sure to read "PRECAUTIONS for Electrical Circuit Service" (Refer to page 4-1) before inspection and observe what is written there.

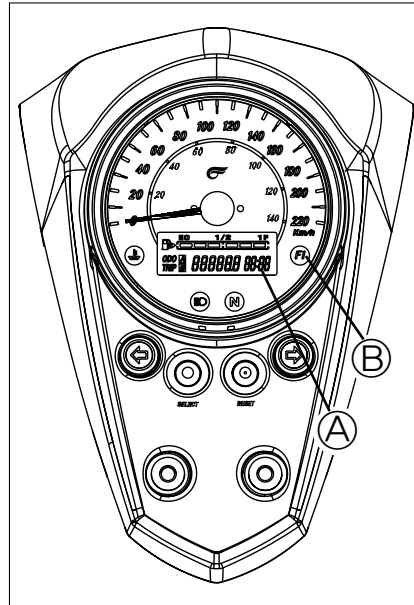

▣ LCD (DISPLAY) INDICATION

☞ Refer to page 4-11

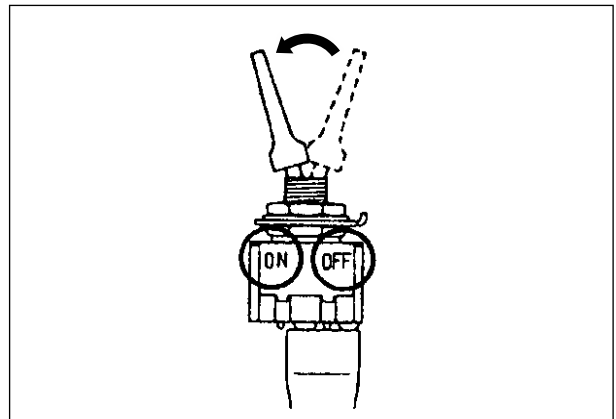

▣ "FI" CHECK LAMP INDICATION

☞ Refer to page 4-13

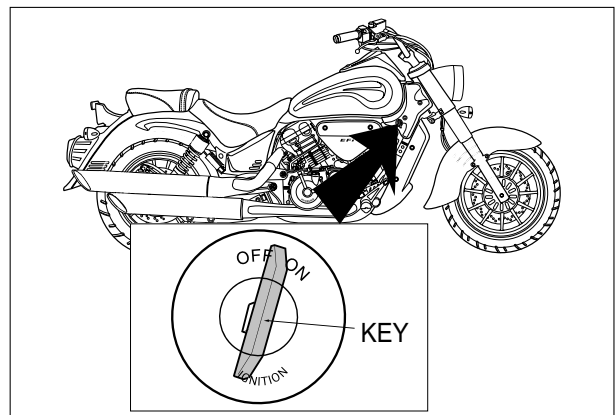

SELF-DIAGNOSIS RESET PROCEDURE

▣ A. LCD (DISPLAY) PANEL ①

- After repairing the trouble, turn the ignition switch “OFF” position and turn “ON” position again.
- If “noEr” then CLOCK (LCD INDICATION ①) is indicates, the malfunction codes are cleared.
- Disconnect the special tool from the dealer mode coupler.

▣ B. “FI” CHECK LAMP ②

- Repair the trouble.
- Turn the ignition switch “OFF” position and turn “ON” position, and wait for 10 seconds.
- Repeat the above procedure 30 times.

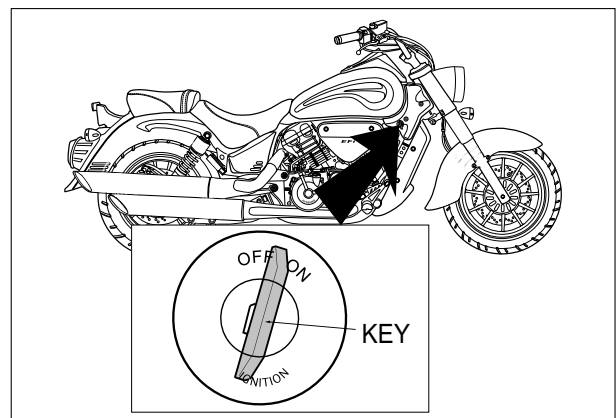
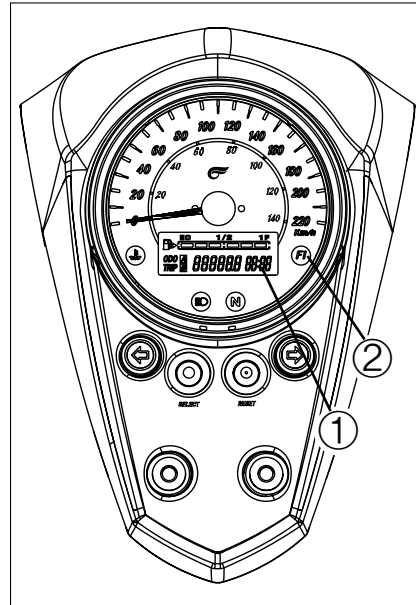

MALFUNCTION CODE AND DEFECTIVE CONDITION

MALFUNCTION CODE	DETECTED ITEM		DETECTED FAILURE CONDITION
			CHECK FOR
noEr	NO FAULT		—
0031	NO.1 O ₂ S heater Circuit	Low Voltage	After engine running, if oxygen sensor heater signal open or is happened the ground short fault for 1 second by 10 times in 12 times test cycle, the code 0031 is indicated.
			Oxygen sensor, lead wire / coupler connection.
0032	NO.1 O ₂ S heater Circuit	High Voltage	After engine running, if oxygen sensor heater signal is happened the high short fault for 1 second by 10 times in 12 times test cycle, the code 0032 is indicated.
			Oxygen sensor, lead wire / coupler connection.
0037	NO.2 O ₂ S heater Circuit	Low Voltage	After engine running, if oxygen sensor heater signal open or is happened the ground short fault for 1 second by 10 times in 12 times test cycle, the code 0037 is indicated.
			Oxygen sensor, lead wire / coupler connection.
0038	NO.2 O ₂ S heater Circuit	High Voltage	After engine running, if oxygen sensor heater signal is happened the high short fault for 1 second by 10 times in 12 times test cycle, the code 0038 is indicated.
			Oxygen sensor, lead wire / coupler connection.
0107	IAPS Circuit	Low Voltage or Open	The sensor should produce following voltage. 0.15 V ≤ Sensor output voltage Without the above range for 2.2 sec. and more, 0107 is indicated.
			Intake air pressure sensor, lead wire / coupler connection.
0108	IAPS Circuit	High Voltage	The sensor should produce following voltage. Sensor output voltage ≤ 5 V Without the above range for 10.0 sec. and more, 0108 is indicated.
			Intake air pressure sensor, lead wire / coupler connection.
0112	IATS Circuit	Low Voltage	The sensor voltage should be the following. 0.1 V ≤ Sensor output voltage Without the above range for 6.25 sec. and more, 0112 is indicated.
			Intake air temperature sensor, lead wire / coupler connection.
0113	IATS Circuit	High Voltage or Open	The sensor voltage should be the following. Sensor output voltage ≤ 4.9 V Without the above range for 6.25 sec. and more, 0113 is indicated.
			Intake air temperature sensor, lead wire / coupler connection.

MALFUNCTION CODE	DETECTED ITEM		DETECTED FAILURE CONDITION
			CHECK FOR
0117	WTS Circuit	Low Voltage	The sensor voltage should be the following. $0.1 \text{ V} \leq \text{Sensor output voltage}$ Without the above range for 6.25 sec. and more, 0117 is indicated.
			Water temperature sensor, lead wire / coupler connection.
0118	WTS Circuit	High Voltage or Open	The sensor voltage should be the following. Sensor output voltage $\leq 5 \text{ V}$ Without the above range for 6.25 sec. and more, 0118 is indicated.
			Water temperature sensor, lead wire / coupler connection.
0122	TPS Circuit	Low Voltage or Open	The sensor should produce following voltage. $0.2 \text{ V} \leq \text{Sensor output voltage}$ Without the above range for 7.8 sec. and more, 0122 is indicated.
			Throttle position sensor, lead wire / coupler connection.
0123	TPS Circuit	High Voltage	The sensor should produce following voltage. Sensor output voltage $\leq 4.9 \text{ V}$ Without the above range for 7.8 sec. and more, 0123 is indicated.
			Throttle position sensor, lead wire / coupler connection.
0131	NO.1 O ₂ S Circuit	Low Voltage	After engine running, the oxygen sensor signal is inputted in ECU since then 300 sec. In this case, the sensor voltage should be the following. $30 \text{ mV} \leq \text{Sensor output voltage}$ Without the above range for 28.1 sec. and more, 0131 is indicated.
			Oxygen sensor, lead wire / coupler connection.
0132	NO.1 O ₂ S Circuit	High Voltage	After engine running, the oxygen sensor signal is inputted in ECU since then 300 sec. In this case, the sensor voltage should be the following. Sensor output voltage $\leq 1.0 \text{ V}$ Without the above range for 29.4 sec. and more, 0132 is indicated.
			Oxygen sensor, lead wire / coupler connection.
0137	NO.2 O ₂ S Circuit	Low Voltage	After engine running, the oxygen sensor signal is inputted in ECU since then 300 sec. In this case, the sensor voltage should be the following. $30 \text{ mV} \leq \text{Sensor output voltage}$ Without the above range for 28.1 sec. and more, 0137 is indicated.
			Oxygen sensor, lead wire / coupler connection.
0138	NO.2 O ₂ S Circuit	High Voltage	After engine running, the oxygen sensor signal is inputted in ECU since then 300 sec. In this case, the sensor voltage should be the following. Sensor output voltage $\leq 1.0 \text{ V}$ Without the above range for 29.4 sec. and more, 0138 is indicated.
			Oxygen sensor, lead wire / coupler connection.

4-25 EI SYSTEM DIAGNOSIS

MALFUNCTION CODE	DETECTED ITEM		DETECTED FAILURE CONDITION
			CHECK FOR
0201	NO.1 Fuel Injector Circuit Malfunction		After engine running, if NO.1 fuel injector signal open or is happened the high / ground short fault for 1 second by 5 times in 10 times test cycle, the code 0201 is indicated.
			Injector, wiring / coupler connection, power supply to the injector.
0202	NO.2 Fuel Injector Circuit Malfunction		After engine running, if NO.2 fuel injector signal open or is happened the high / ground short fault for 1second by 5 times in 10 times test cycle, the code 0202 is indicated.
			Injector, wiring / coupler connection, power supply to the injector.
0230	Fuel pump relay Circuit	Low Voltage or Open	After engine running, if fuel pump relay signal open or is happened the ground short fault for 1 second by 10 times in 20 times test cycle, the code 0230 is indicated.
			Fuel pump relay, connecting lead wire, power source to fuel pump relay, fuel injector.
0232		High Voltage	After engine running, if fuel pump relay signal is happened the high short fault for 1 second by 10 times in 20 times test cycle, the code 0232 is indicated.
			Fuel pump relay, connecting lead wire, power source to fuel pump relay, fuel injector.
0336	Pick-up coil	Noisy Signal	After engine running, if the magneto rotor tooth's error is happened continuously by 10 times in 100 times test cycle, the code 0336 is indicated.
			Pick-up coil wiring and mechanical parts. (Pick-up coil, lead wire coupler connection)
0337		No Signal	After engine running, if the pick-up coil signal does not reach ECU for more than 0.5 sec., the code 0337 is indicated.
			Pick-up coil wiring and mechanical parts. (Pick-up coil, lead wire coupler connection)
0351	NO.1 IG coil Malfunction		After engine running, if NO.1 ignition coil signal open or is happened the high / ground short fault for 1 second by 5 times in 10 times test cycle, the code 0351 is indicated.
			Ignition coil, wiring / coupler connection, power supply from the battery.
0352	NO.2 IG coil Malfunction		After engine running, if NO.2 ignition coil signal open or is happened the high / ground short fault for 1 second by 5 times in 10 times test cycle, the code 0352 is indicated.
			Ignition coil, wiring / coupler connection, power supply from the battery.

MALFUNCTION CODE	DETECTED ITEM		DETECTED FAILURE CONDITION
			CHECK FOR
0444	PV Circuit (California model only)	Open	After engine running, if purge control valve signal open or is happened the ground short fault for 1 second by 10 times in 12 times test cycle, the code 0444 is indicated.
			Purge control valve, wiring / coupler connection, power supply from the battery.
0445	PV Circuit (California model only)	Shorted	After engine running, if purge control valve signal is happened the high short fault for 1 second by 10 times in 12 times test cycle, the code 0445 is indicated.
			Purge control valve, wiring / coupler connection, power supply from the battery.
0505	ISC Error		After engine running, if idle speed is different to 500 rpm from the specified range in 25 seconds test cycle, the code 0505 is indicated.
			Idle speed control solenoid, wiring / coupler connection.
0562	Battery Voltage	Low	The battery voltage should be the following. $9\text{ V} \leq \text{Battery voltage}$ Without the above range for 3.125 sec. and more, 0562 is indicated.
			Battery, wiring / coupler connection to ECU.
0563	Battery Voltage	High	The battery voltage should be the following. $\text{Battery voltage} \leq 16\text{ V}$ Without the above range for 3.125 sec. and more, 0563 is indicated.
			Battery, wiring / coupler connection to ECU.
0650	"FI" check lamp Circuit Malfunction		After engine running, if "FI" check lamp signal open or is happened the high / ground short fault for 1 second by 40 times in 80 times test cycle, the code 0650 is indicated.
			"FI" check lamp, wiring / coupler connection.
0850	GP or Clutch lever Switch Circuit Malfunction		If gear position or clutch lever switch signal feedback is not active in continuous by 20 times in fully power down cycles, the code 0850 is indicated. (Fully power down cycle : Ignition switch "ON" → "OFF" position)
			Gear position or clutch lever switch, wiring / coupler connection, gearshift cam etc.

**“0031”, “0032”, “0037” or “0038”
 OXYGEN SENSOR HEATER CIRCUIT MALFUNCTION &
 “0131”, “0132”, “0137” or “0138”
 OXYGEN SENSOR CIRCUIT MALFUNCTION**

LCD (DISPLAY) INDICATION	“FI” CHECK LAMP INDICATION
0031	
0032	
0037	
0038	
0131	
0132	
0137	
0138	

DETECTED CONDITION	POSSIBLE CAUSE
Refer to page 4-23, 24	<ul style="list-style-type: none"> ● Oxygen sensor, Oxygen sensor heater circuit open or short. ● Oxygen sensor, Oxygen sensor heater malfunction. ● ECU malfunction.

INSPECTION

- 1) Remove the front seat and right side cover.
- 2) Turn the ignition switch "OFF" position.
- 3) Check the Oxygen sensor coupler for loose or poor contacts.

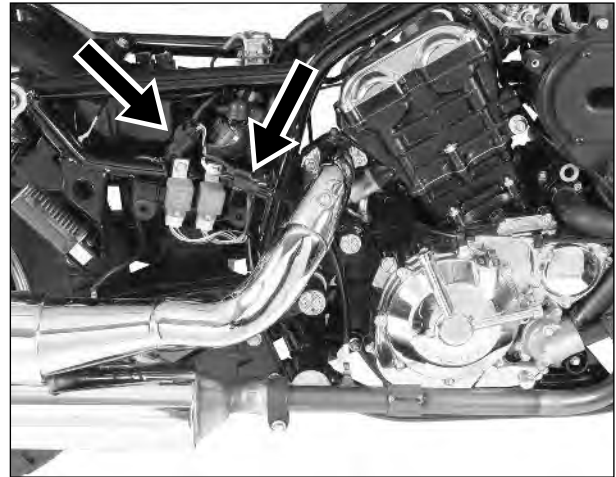
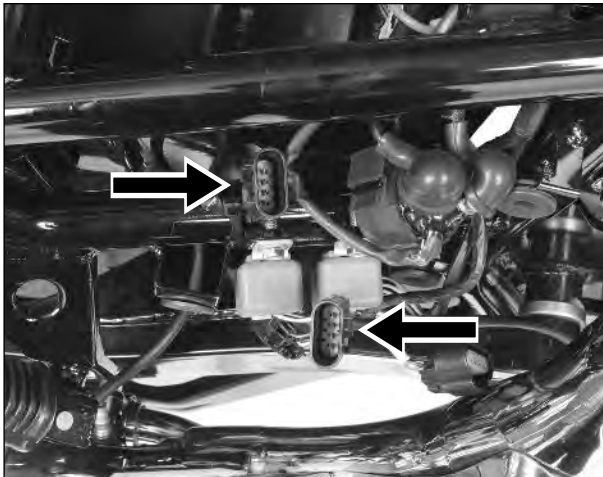

Is OK?

YES	<ul style="list-style-type: none"> ● B or GR (NO.1 O₂S) / R or GR (NO.2 O₂S) wire open or shorted to ground, or poor (B7) or (B10) (NO.1 O₂S) / (G5) or (B10) (NO.2 O₂S) connection of ECU coupler. (Sensor side) ● YL or W (NO.1 O₂S heater) / YL or L (NO.2 O₂S heater) wire open or shorted to ground, or poor (B7) (NO.1 O₂S heater) / (G4) (NO.2 O₂S heater) connection of ECU coupler. YL coupler open or shorted to the wiring harness. (Heater side) ● If wire and connection are OK, intermittent trouble or faulty ECU. ● Recheck each terminal and wire harness for open circuit and poor connection.
NO	Replace the Oxygen sensor with a new one.

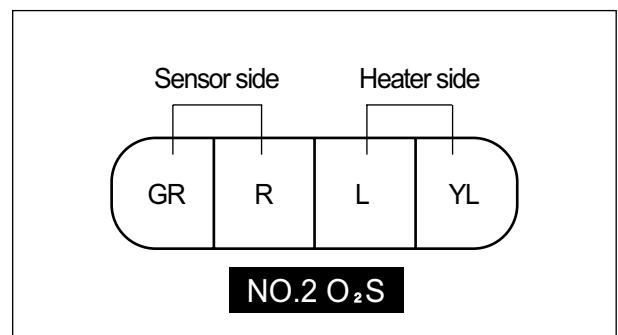
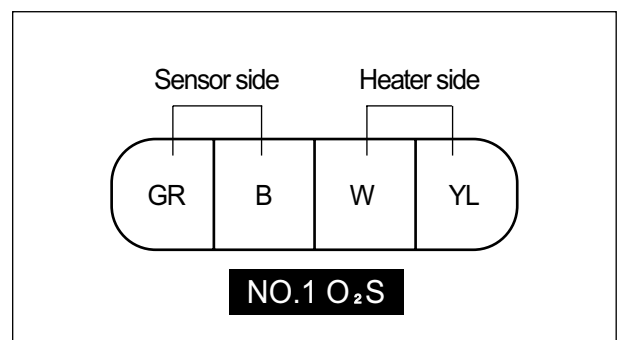
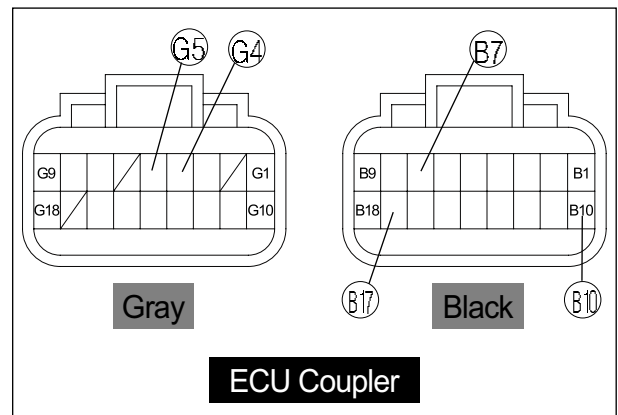

“0107” or “0108” IAP SENSOR CIRCUIT MALFUNCTION

LCD (DISPLAY) INDICATION	“FI” CHECK LAMP INDICATION
0107	
0108	

DETECTED CONDITION	POSSIBLE CAUSE
<p>☛ Refer to page 4-23</p> <p><i>NOTE :</i> Note that atmospheric pressure varies depending on weather conditions as well as altitude. Take that into consideration when inspecting voltage.</p>	<ul style="list-style-type: none"> ● Clogged vacuum passage between throttle body and IAP sensor. ● Air being drawn from vacuum passage between throttle body and IAP sensor. ● IAP sensor circuit open or shorted to ground. ● IAP sensor malfunction. ● ECU malfunction.

INSPECTION

Step 1

- 1) Remove the fuel tank.
- 2) Turn the ignition switch “OFF” position.
- 3) Check the IAP sensor coupler ① for loose or poor contacts.
 If OK, then measure the IAP sensor input voltage.

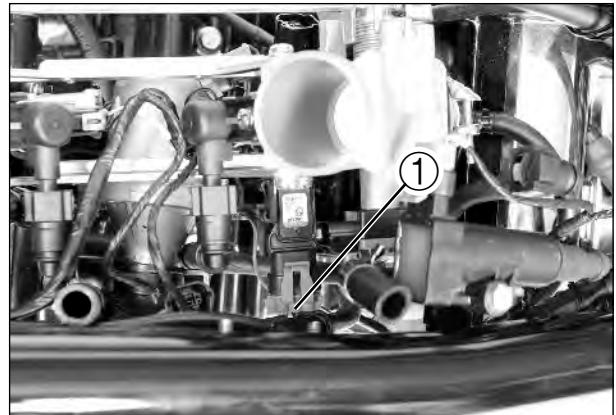

- 4) Disconnect the IAP sensor coupler ②.
- 5) Turn the ignition switch “ON” position.
- 6) Measure the input voltage at the OB wire and ground.
 If OK, then measure the input voltage at the OB wire and GR wire.

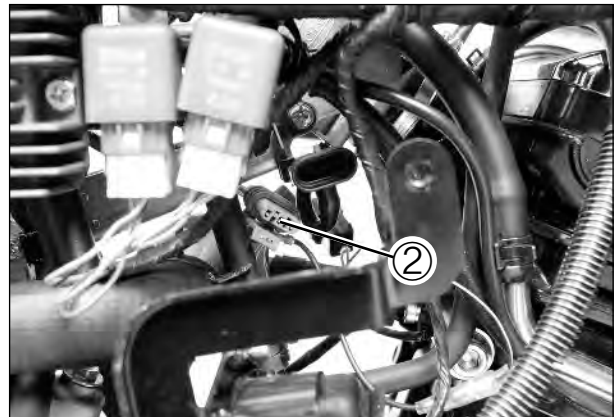

IAP sensor input voltage

4.5 ~ 5.5 V
 (⊕ OB — ⊖ Ground)
 (⊕ OB — ⊖ GR)

Tester knob indication : Voltage (---)

Is the input voltage OK?

YES	Go to Step 2.
NO	<ul style="list-style-type: none"> ● Loose or poor contacts on the ECU coupler. ● Open or short circuit in the OB wire or GR wire.

◆ **Step 2**

- 1) Connect the IAP sensor coupler ①.
- 2) Insert the needle pointed probes to the lead wire coupler.
- 3) Start the engine at idle speed.
- 4) Measure the IAP sensor output voltage at the wire side coupler (between BL and GR wires).

IAP sensor output voltage	Approx. 2.7 V at idle speed (⊕ BL – ⊖ GR)
----------------------------------	--

 **Tester knob indication : Voltage (---)**

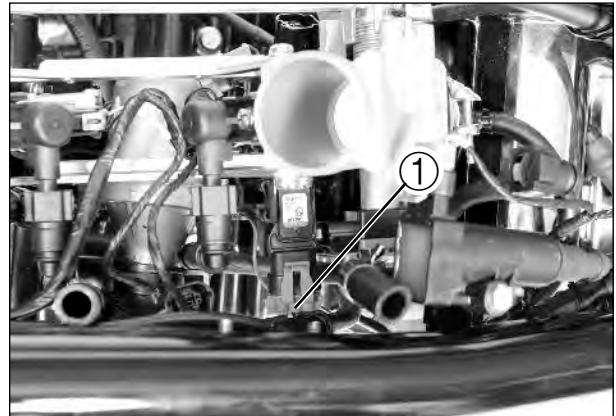

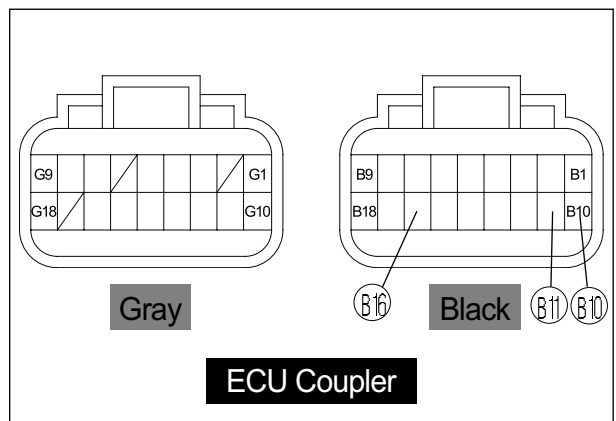

Is the voltage OK?

YES	<ul style="list-style-type: none"> ● OB, BL or GR wire open or shorted to ground, or poor (B16), (B11) or (B10) connection of ECU coupler. ● If wire and connection are OK, intermittent trouble or faulty ECU. ● Recheck each terminal and wire harness for open circuit and poor connection.
NO	If check result is not satisfactory, replace the IAP sensor with a new one.



Output voltage (Input voltage 5 V, ambient temp. 25 °C, 77 °F)				
ALTITUDE (Reference)		ATMOSPHERIC PRESSURE		OUTPUT VOLTAGE
(ft)	(m)	(mmHg)	kPa	(V)
0	0	760	100	Approx. 3.7 ~ 3.9
2 000	610	707	94	
2 001	611	707	94	Approx. 3.3 ~ 3.7
5 000	1 524	634	85	
5 001	1 525	634	85	Approx. 3.0 ~ 3.3
8 000	2 438	567	76	
8 001	2 439	567	76	Approx. 2.7 ~ 3.0
10 000	3 048	526	70	

“0112” or “0113” IAT SENSOR CIRCUIT MALFUNCTION

LCD (DISPLAY) INDICATION	“FI” CHECK LAMP INDICATION
0112	
0113	

DETECTED CONDITION	POSSIBLE CAUSE
<p>☞ Refer to page 4-23</p>	<ul style="list-style-type: none"> ● IAT sensor circuit open or short. ● IAT sensor malfunction. ● ECU malfunction.

INSPECTION

- 1) Remove the fuel tank.
- 2) Turn the ignition switch “OFF” position.
- 3) Check the IAT sensor coupler for loose or poor contacts.
If OK, then measure the IAT sensor resistance.
- 4) Disconnect the IAT sensor coupler.

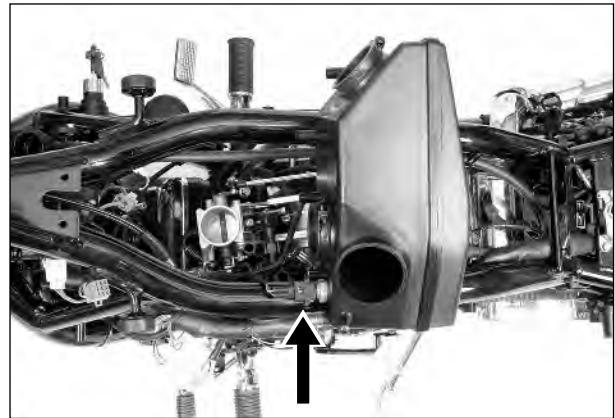

- 5) Measure the resistance between the terminals ① and ②.

IAT sensor resistance	0.081 ~ 48.352 KΩ [When Intake air temperature is -40°C ~ 130°C (-40°F ~ 266°F)]
------------------------------	--

 Tester knob indication : Resistance (KΩ)

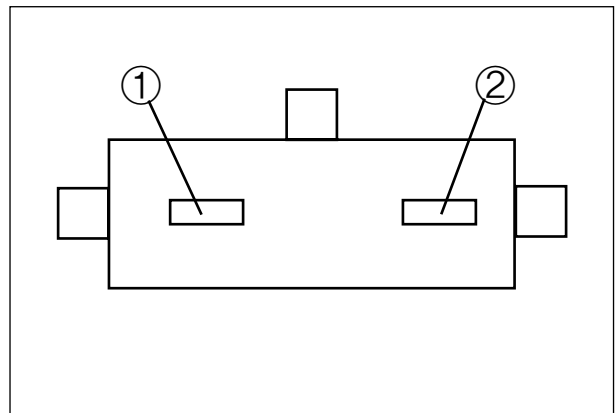
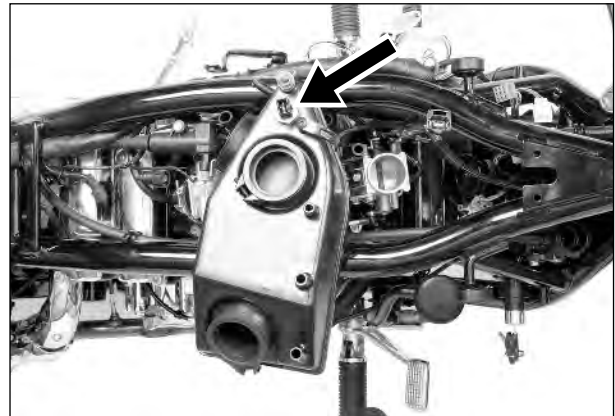

NOTE

IAT sensor resistance measurement method is the same way as that of the WT sensor. Refer to page 6-8 for details.

IAT sensor resistance	
Intake Air Temp.	Resistance
-40 °C (-40 °F)	44.642 KΩ ± 5%
-20 °C (-4 °F)	14.958 KΩ ± 5%
0 °C (32 °F)	5.734 KΩ ± 5%
20 °C (68 °F)	2.438 KΩ ± 5%
40 °C (104 °F)	1.141 KΩ ± 5%
60 °C (140 °F)	0.579 KΩ ± 5%
80 °C (176 °F)	0.315 KΩ ± 5%
100 °C (212 °F)	0.182 KΩ ± 5%
120 °C (248 °F)	0.111 KΩ ± 5%
130 °C (266 °F)	0.088 KΩ ± 5%

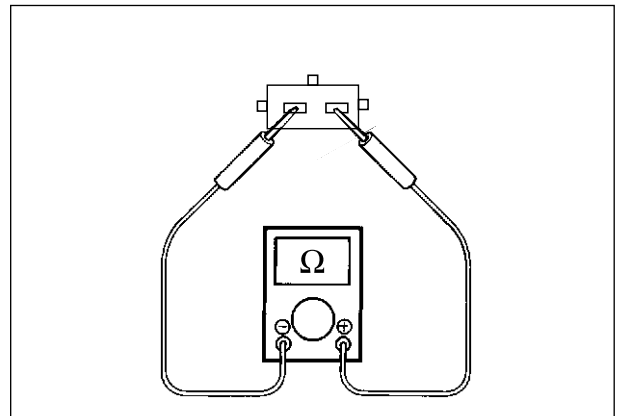



 Tester knob indication : Resistance (KΩ)

Is the resistance OK?

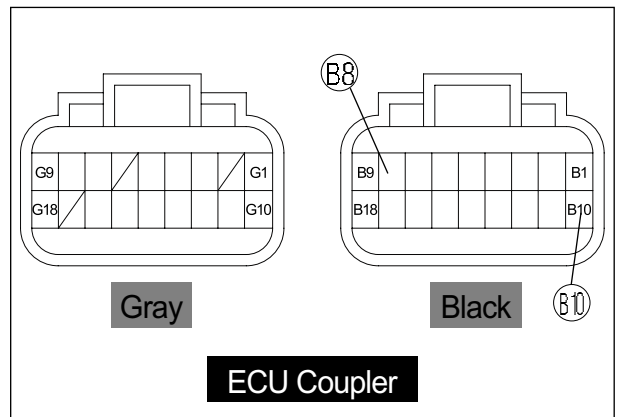
YES	<ul style="list-style-type: none"> ● Lg or GR wire open or shorted to ground, or poor (B8) or (B10) connection of ECU coupler. ● If wire and connection are OK, intermittent trouble or faulty ECU. ● Recheck each terminal and wire harness for open circuit and poor connection.
NO	Replace the IAT sensor with a new one.



“0117” or “0118” WT SENSOR CIRCUIT MALFUNCTION

LCD (DISPLAY) INDICATION	“FI” CHECK LAMP INDICATION
0117	 [0 1 1 7 0 1 1 7]
0118	 [0 1 1 8 0 1 1 8]

DETECTED CONDITION	POSSIBLE CAUSE
☞ Refer to page 4-24	<ul style="list-style-type: none"> ● WT sensor circuit open or short. ● WT sensor malfunction. ● ECU malfunction.

▣ INSPECTION

- 1) Turn the ignition switch “OFF” position.
- 2) Check the WT sensor coupler for loose or poor contacts.
If OK, then measure the WT sensor resistance.
(Refer to page 6-8 for details.)

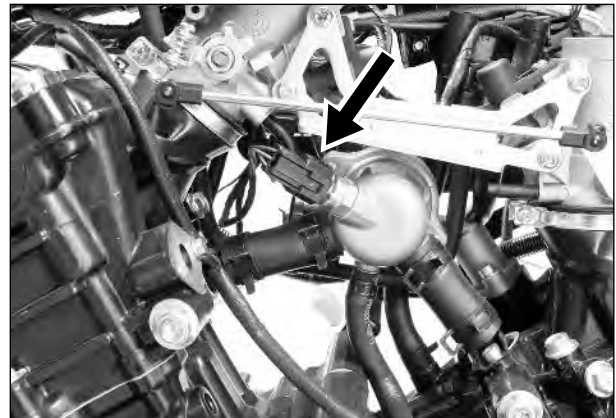

- 3) Disconnect the WT sensor coupler.
- 4) Measure the resistance between the terminals ① and ③.

WT sensor resistance	0.1163 ~ 48.1400 KΩ [When Water temperature is -40°C ~ 120°C (-40°F ~ 248°F)]
-----------------------------	---

 Tester knob indication : Resistance (KΩ)

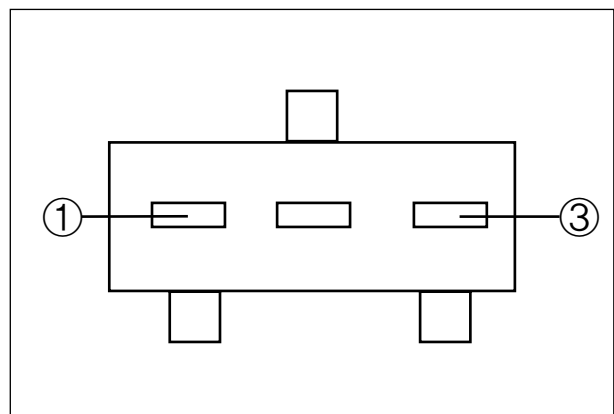
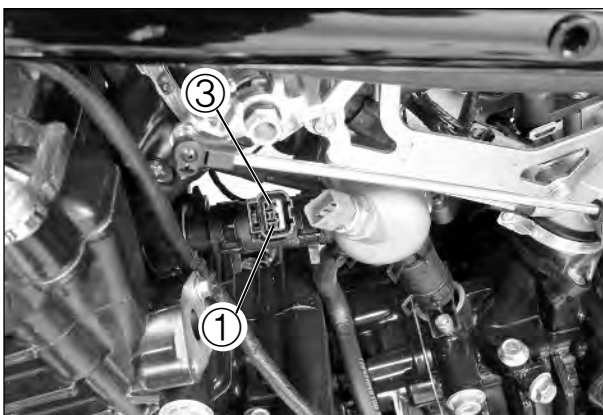
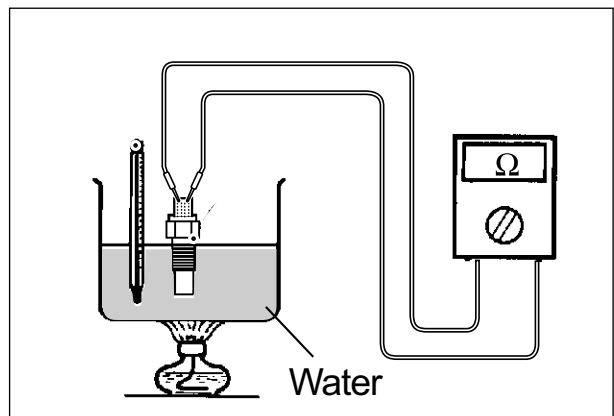

WT sensor resistance	
Engine Coolant Temp.	Resistance (To ECU)
-40 °C (-40 °F)	Approx. 48.140 KΩ
0 °C (32 °F)	Approx. 5.790 KΩ
20 °C (68 °F)	Approx. 2.450 KΩ
40 °C (104 °F)	Approx. 1.148 KΩ
60 °C (140 °F)	Approx. 0.586 KΩ
80 °C (176 °F)	Approx. 0.322 KΩ
120 °C (248 °F)	Approx. 0.1163 KΩ

 Tester knob indication : Resistance (KΩ)

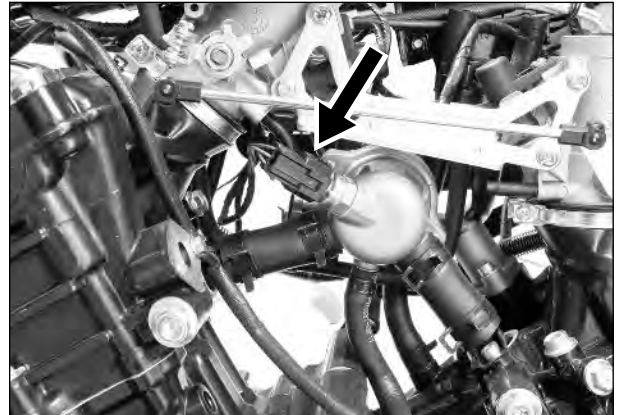

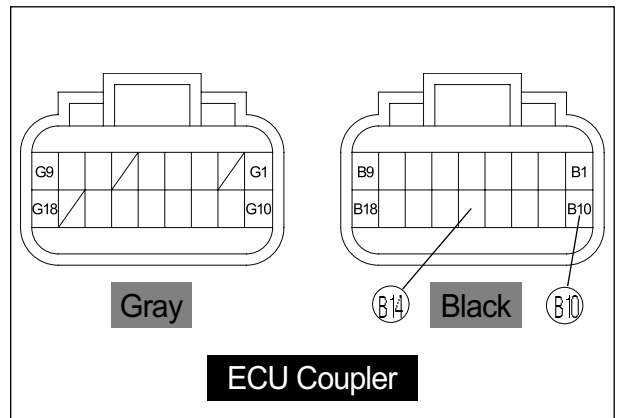

Is the resistance OK?

YES	<ul style="list-style-type: none"> ● G or GR wire open or shorted to ground, or poor B14 or B10 connection of ECU coupler. ● If wire and connection are OK, intermittent trouble or faulty ECU. ● Recheck each terminal and wire harness for open circuit and poor connection.
NO	Replace the WT sensor with a new one.



“0122” or “0123” TP SENSOR CIRCUIT MALFUNCTION

LCD (DISPLAY) INDICATION	“FI” CHECK LAMP INDICATION
0122	
0123	

DETECTED CONDITION	POSSIBLE CAUSE
☞ Refer to page 4-24	<ul style="list-style-type: none"> ● TP sensor circuit open or short. ● TP sensor malfunction. ● ECU malfunction.

INSPECTION

◆ Step 1

- 1) Turn the ignition switch “OFF” position.
- 2) Check the TP sensor coupler for loose or poor contacts.
If OK, then measure the TP sensor input voltage.
- 3) Disconnect the TP sensor coupler ①.

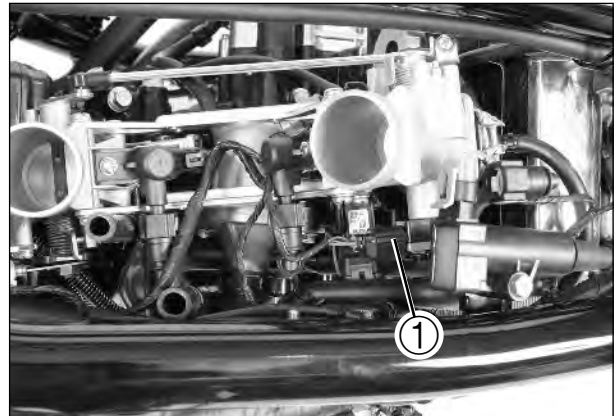

- 4) Turn the ignition switch “ON” position.
- 5) Measure the voltage at the OB wire and ground.
- 6) If OK, then measure the voltage at the OB wire and GR wire.



TP sensor input voltage	4.9 ~ 5.1 V (⊕ OB — ⊖ Ground) (⊕ OB — ⊖ GR)
--------------------------------	---

 Tester knob indication : Voltage (---)

Is the input voltage OK?

YES	Go to Step 2.
NO	<ul style="list-style-type: none"> ● Loose or poor contacts on the ECU coupler. ● Open or short circuit in the OB wire or GR wire.

◆ **Step 2**

- 1) Remove the frame cover.
- 2) Turn the ignition switch "OFF" position.
- 3) Disconnect the TP sensor coupler.
- 4) Check the continuity between (A) (LY) and ground.

TP sensor continuity	$\infty \Omega$ (Infinity) (A - Ground)
-----------------------------	--

 **Tester knob indication : Resistance (Ω)**

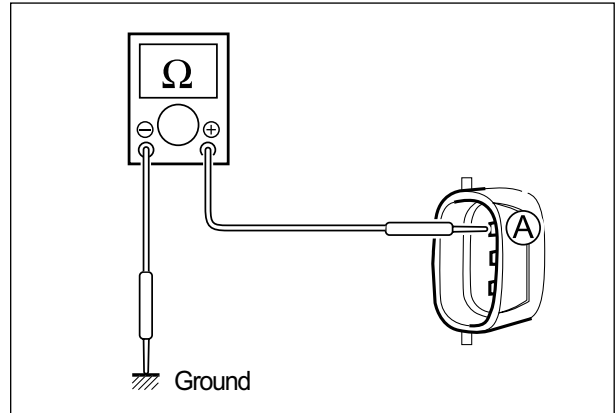

Is the continuity OK?

YES	Go to Step 3.
NO	Replace the TP sensor with a new one.

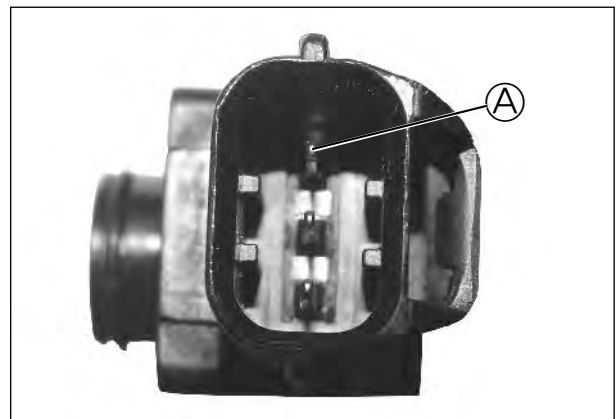

◆ **Step 3**

- 1) Connect the TP sensor coupler.
- 2) Insert the needle pointed probes to the lead wire coupler.
- 3) Turn the ignition switch "ON" position.
Measure the TP sensor output voltage at the coupler [between \oplus (A : LY) and \ominus (C : GR)] by turning the throttle grip.

TP sensor output voltage	
Throttle valve is closed	Approx. 1.07 ~ 1.17 V
Throttle valve is opened	Approx. 4.30 ~ 4.70 V

 **Tester knob indication : Voltage (---)**

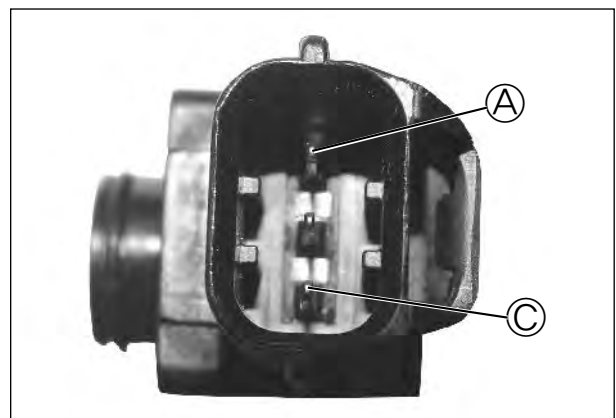
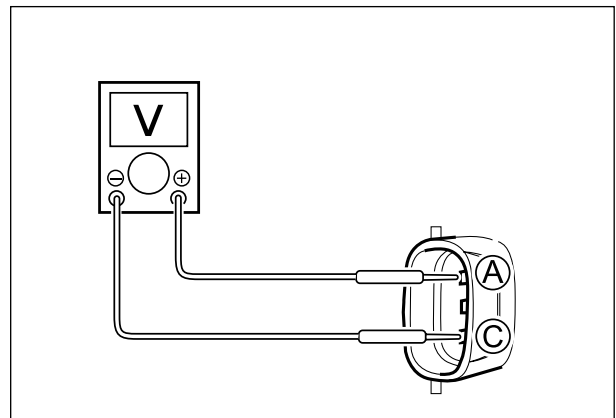

4-37 EI SYSTEM DIAGNOSIS

Is the output voltage OK?

YES	<ul style="list-style-type: none"> ● OB, LY or GR wire open or shorted to ground, or poor (B16), (B12), or (B10) connection of ECU coupler. ● If wire and connection are OK, intermittent trouble or faulty ECU. ● Recheck each terminal and wire harness for open circuit and poor connection.
NO	<p>If check result is not satisfactory, replace the TP sensor with a new one.</p>

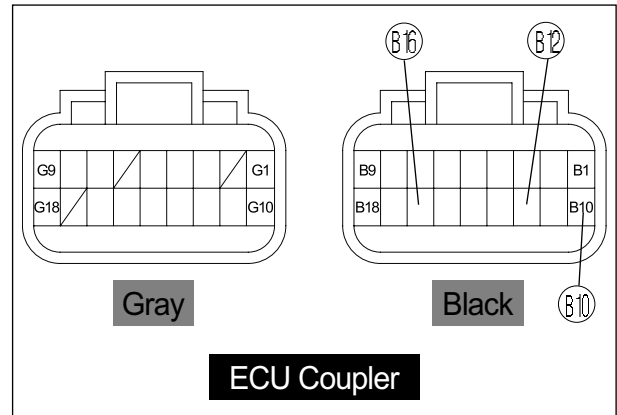

“0201” or “0202” FUEL INJECTOR CIRCUIT MALFUNCTION

LCD (DISPLAY) INDICATION	“FI” CHECK LAMP INDICATION
0201	[0 2 0 1 0 2 0 1]
0202	[0 2 0 2 0 2 0 2]

DETECTED CONDITION	POSSIBLE CAUSE
<p>Refer to page 4-25</p>	<ul style="list-style-type: none"> ● Injector circuit open or short. ● Injector malfunction. ● ECU malfunction.

INSPECTION

Step 1

- 1) Remove the fuel tank and frame cover.
- 2) Turn the ignition switch “OFF” position.
- 3) Check the injector couplers NO.1 ① and NO.2 ② for loose or poor contacts.
If OK, then measure the injector resistance.

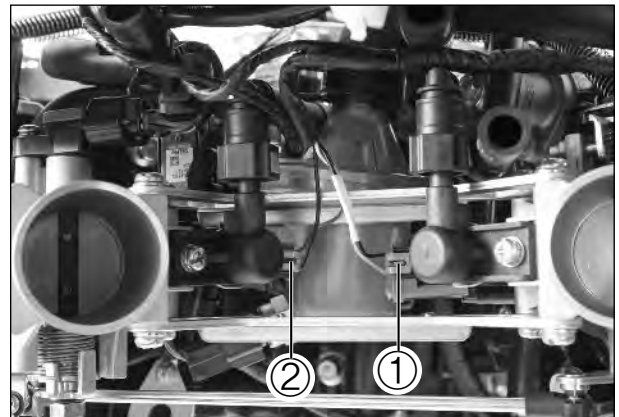

- 4) Disconnect the injector couplers NO.1 ① and NO.2 ② and measure the resistance between terminals.

Injector resistance

11.4 ~ 12.6 Ω
at 20°C (68°F)

Tester knob indication : Resistance (Ω)

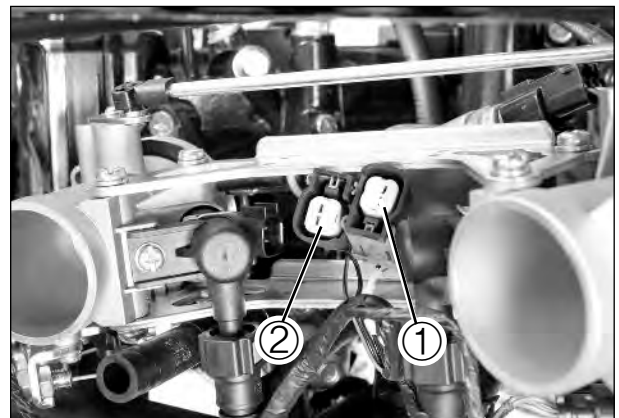

- 5) If OK, then check the continuity between injector terminals and ground.

Injector continuity

∞ Ω (Infinity)

Tester knob indication : Resistance (Ω)

Are the resistance and continuity OK?

YES	Go to Step 2
NO	Replace the Injector with a new one.

4-39 EI SYSTEM DIAGNOSIS

◆ Step 2

- 1) Turn the ignition switch "ON" position.
- 2) Measure the injector voltage between YR(NO.1) or RB(NO.2) wire and ground.

Injector voltage	Battery voltage ([NO.1] ⊕ YR – ⊖ Ground, [NO.2] ⊕ RB – ⊖ Ground)
-------------------------	--

 **Tester knob indication : Voltage (---)**

NOTE

Injector voltage can be detected only 3 seconds after ignition switch is turned "ON" position.

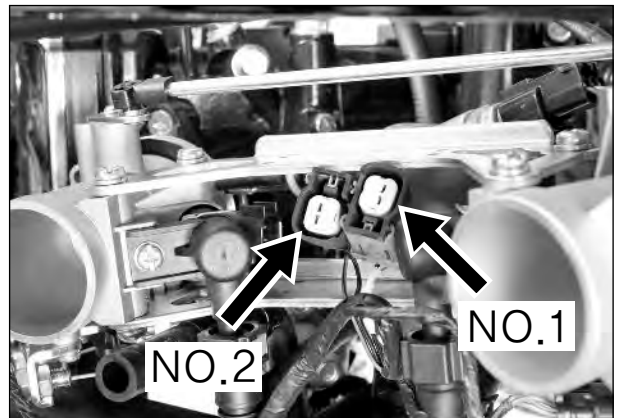
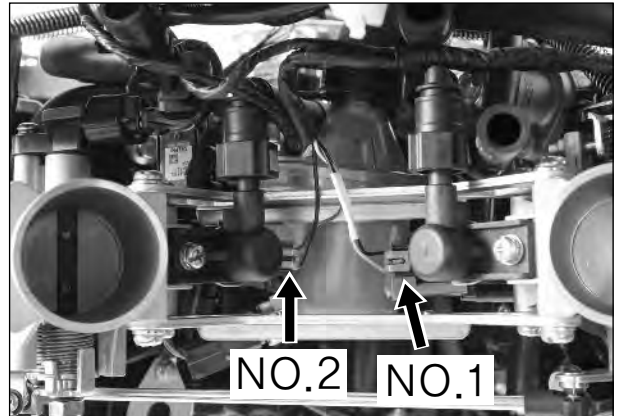

Is the voltage OK?

YES	<ul style="list-style-type: none"> ● YR(NO.1), RB(NO.2) wire open or shorted to ground, or poor (B5) (NO.1), (B6) (NO.2) connection of ECU coupler. ● If wire and connection are OK, intermittent trouble or faulty ECU. ● Recheck each terminal and wire harness for open circuit and poor connection.
NO	Inspect the fuel pump or fuel pump relay. (Refer to page 5-4)

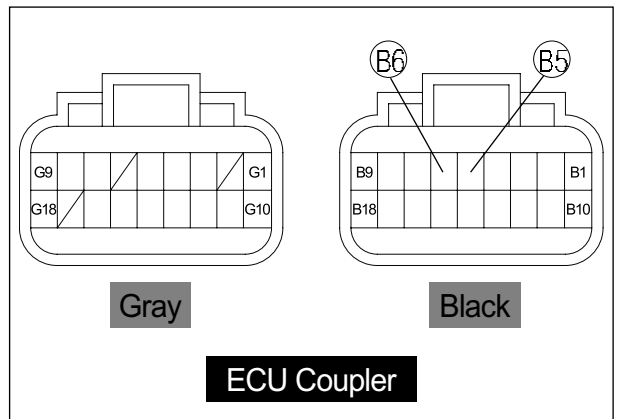

“0230” or “0232” FUEL PUMP RELAY CIRCUIT MALFUNCTION

LCD (DISPLAY) INDICATION	“FI” CHECK LAMP INDICATION
0230	
0232	

DETECTED CONDITION	POSSIBLE CAUSE
<p>☛ Refer to page 4-25</p>	<ul style="list-style-type: none"> ● Fuel pump relay circuit open or short. ● Fuel pump relay malfunction. ● ECU malfunction.

▣ INSPECTION

- 1) Remove the frame cover.
- 2) Turn the ignition switch “OFF” position.
- 3) Check the fuel pump relay coupler for loose or poor contacts.
If OK, then check the insulation and continuity.
Refer to page 5-4 for details.

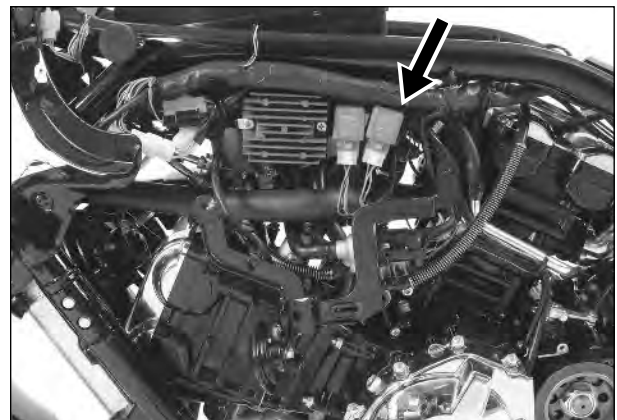

Is the Fuel pump relay OK?

YES	<ul style="list-style-type: none"> ● GW wire open or shorted to ground, or poor (B9) connection of ECU coupler. ● If wire and connection are OK, intermittent trouble or faulty ECU. ● Recheck each terminal and wire harness for open circuit and poor connection. ● Inspect the fuel injectors. (Refer to page 4-38)
NO	Replace the fuel pump relay with a new one.

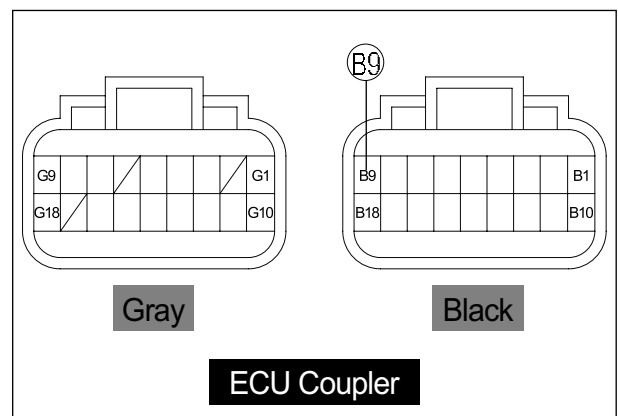

“0336” or “0337” PICK-UP COIL CIRCUIT MALFUNCTION

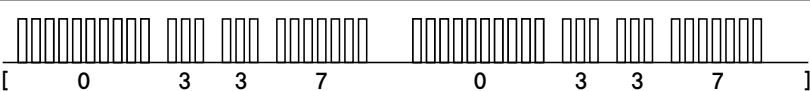
LCD (DISPLAY) INDICATION	“FI” CHECK LAMP INDICATION
0336	
0337	

DETECTED CONDITION	POSSIBLE CAUSE
☞ Refer to page 4-25	<ul style="list-style-type: none"> ● Metal particles or foreign material being attached on the pick-up coil and rotor tip. ● Pick-up coil circuit open or short. ● Pick-up coil malfunction. ● ECU malfunction.

INSPECTION

- 1) Remove the frame cover.
- 2) Turn the ignition switch “OFF” position.
- 3) Check the pick-up coil coupler ① for loose or poor contacts.

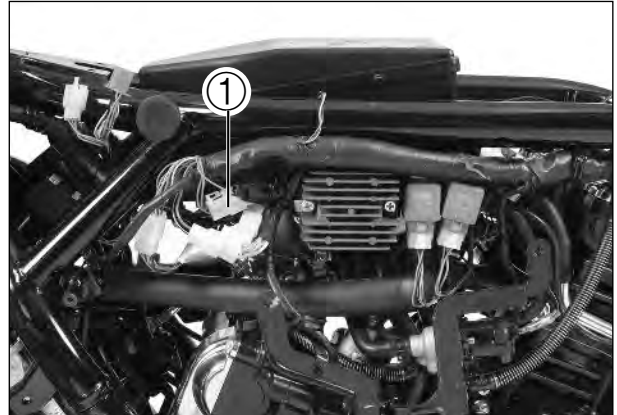

- 4) Disconnect the pick-up coil coupler ① and measure the resistance.

Pick-up coil resistance	110 ~ 140 Ω (G – L)
--------------------------------	------------------------

 Tester knob indication : Resistance (Ω)

- 5) If OK, then check the continuity between each terminal and ground.

Pick-up coil continuity	∞ Ω (Infinity) (G – Ground) (L – Ground)
--------------------------------	--

 Tester knob indication : Resistance (Ω)

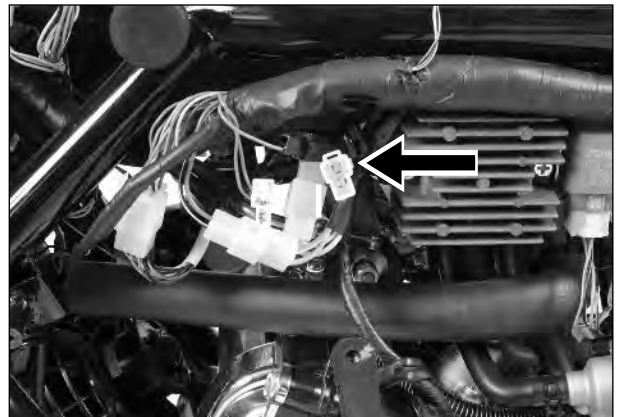

Are the resistance and continuity OK?

YES	<ul style="list-style-type: none"> ● L or G wire open or shorted to ground, or poor B13 or B4 connection of ECU coupler. ● If wire and connection are OK, intermittent trouble or faulty ECU. ● Recheck each terminal and wire harness for open circuit and poor connection.
NO	<ul style="list-style-type: none"> ● Loose or poor contacts on the pick-up coil coupler or ECU coupler. ● Replace the pick-up coil with a new one.

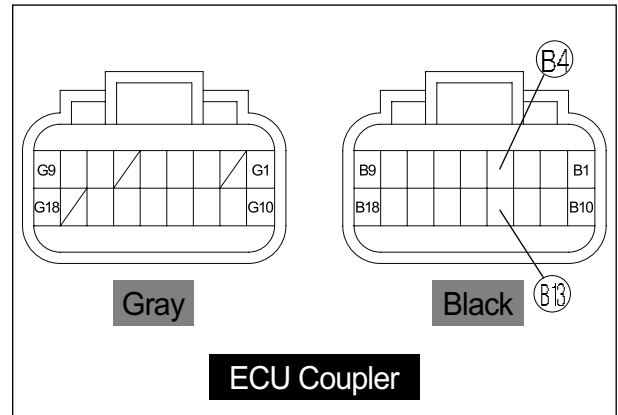

“0351” or “0352” IGNITION COIL MALFUNCTION

☞ Refer to the IGNITION COIL for details.
 (See page 7-5)

LCD (DISPLAY) INDICATION	“FI” CHECK LAMP INDICATION
0351	 [0 3 5 1 0 3 5 1]
0352	 [0 3 5 2 0 3 5 2]

“0444” or “0445” PURGE CONTROL VALVE CIRCUIT MALFUNCTION (California model only)

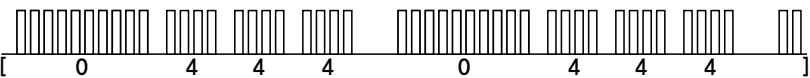
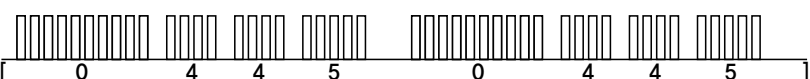
LCD (DISPLAY) INDICATION	“FI” CHECK LAMP INDICATION
0444	
0445	

DETECTED CONDITION	POSSIBLE CAUSE
☞ Refer to page 4-26	<ul style="list-style-type: none"> ● PV circuit open and short. ● PV malfunction. ● ECU malfunction.

▣ INSPECTION

- 1) Remove the frame cover.
- 2) Turn the ignition switch “OFF” position.
- 3) Check the PV coupler for loose or poor contacts.
- 4) Disconnect the PV coupler and measure the resistance.

Purge control valve resistance

19 ~ 22 Ω
[at 20°C (68°F)]

 Tester knob indication : Resistance (Ω)

- 5) If OK, then check the continuity between each terminal and ground.

Purge control valve continuity

∞ Ω (Infinity)

 Tester knob indication : Resistance (Ω)

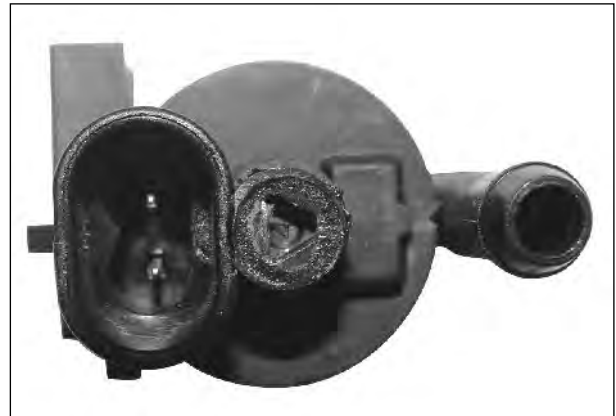

4-45 EI SYSTEM DIAGNOSIS

Are the resistance and continuity OK?

YES	<ul style="list-style-type: none"> ● GW wire open or shorted to ground, or poor Ⓞ connection of ECU coupler. ● YL coupler open or shorted to the wiring harness. ● If wire and connection are OK, intermittent trouble or faulty ECU. ● Recheck each terminal and wire harness for open circuit and poor connection.
NO	Replace the purge control valve with a new one.

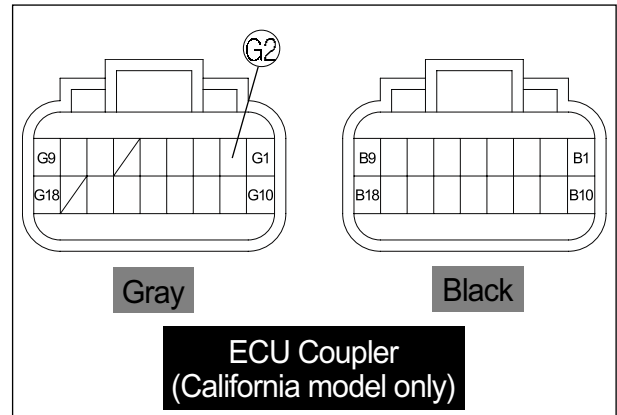

“0505” ISC SOLENOID RANGE ABNORMAL

LCD (DISPLAY) INDICATION	“FI” CHECK LAMP INDICATION
0505	
DETECTED CONDITION	POSSIBLE CAUSE
<p>☛ Refer to page 4-26</p>	<ul style="list-style-type: none"> ● ISC solenoid malfunction. ● ISC solenoid’s step is out of the specified range. ● ECU malfunction.

INSPECTION

- 1) Remove the front seat.
- 2) Turn the ignition switch “OFF” position.
- 3) Check the ISC solenoid coupler for loose or poor contacts.
- 4) Turn the ignition switch “ON” position to check the ISC solenoid operation.

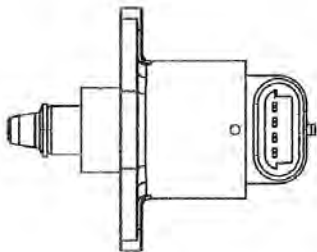
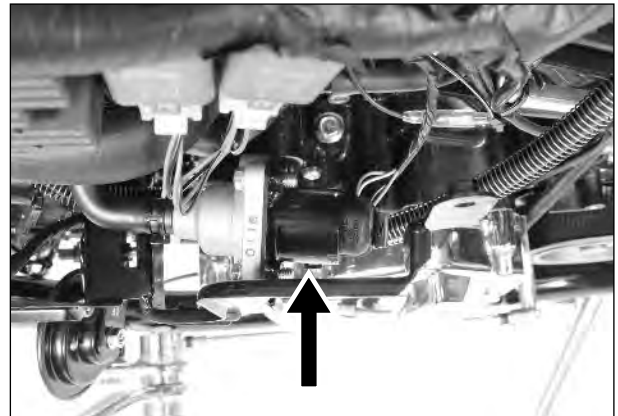

[When Ignition switch “OFF”]

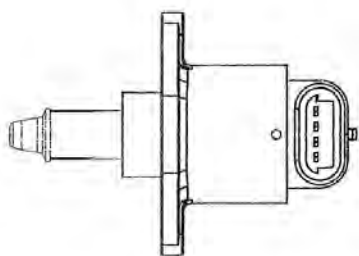

[When Ignition switch “ON”]

Is OK?

YES	<ul style="list-style-type: none"> ● LY, G, BBr or YL wire loose or poor contacts on the ISC solenoid coupler, or poor G13, G12, G11 or G1 connection of ECU coupler. ● If wire and connection are OK, intermittent trouble or faulty ECU. ● Recheck each terminal and wire harness for open circuit and poor connection.
NO	Replace the ISC solenoid with a new one.

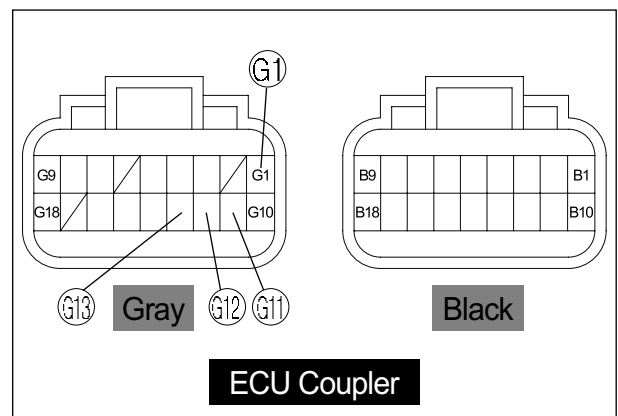

“0562” or “0563” BATTERY VOLTAGE MALFUNCTION

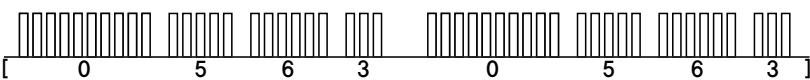
LCD (DISPLAY) INDICATION	“FI” CHECK LAMP INDICATION
0562	
0563	

DETECTED CONDITION	POSSIBLE CAUSE
☞ Refer to page 4-26	<ul style="list-style-type: none"> ● Battery voltage circuit open and short. ● Battery malfunction. ● ECU malfunction.

INSPECTION

- 1) Remove the front seat.
- 2) Turn the ignition switch “OFF” position.
- 3) Using the pocket tester, measure the DC voltage between the battery (+) and (-) terminal.

Battery voltage	11 ~ 16 V
------------------------	-----------

 Tester knob indication : Voltage (---)



Is the battery voltage OK?

YES	<ul style="list-style-type: none"> ● OB, BW or BW wire open or shorted to ground, or poor B15, G9 or B2 connection of ECU coupler. ● If wire and connection are OK, intermittent trouble or faulty ECU. ● Recheck each terminal and wire harness for open circuit and poor connection.
NO	Replace the battery with a new one.

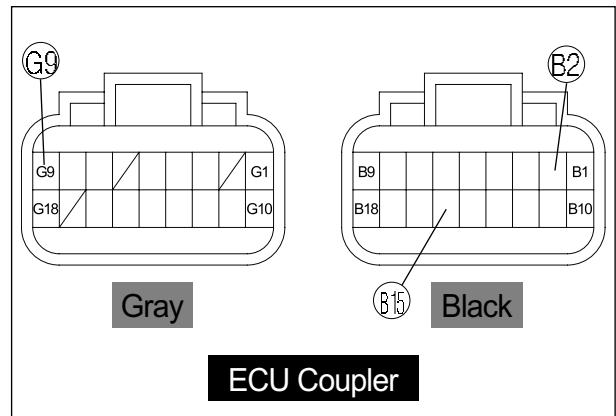

“0650” “FI” CHECK LAMP CIRCUIT MALFUNCTION

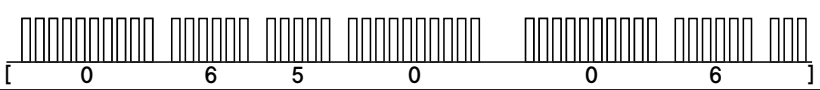
LCD (DISPLAY) INDICATION	“FI” CHECK LAMP INDICATION
0650	

DETECTED CONDITION	POSSIBLE CAUSE
<p>☞ Refer to page 4-26</p>	<ul style="list-style-type: none"> ● “FI” check lamp circuit open and short. ● “FI” check lamp malfunction. ● ECU malfunction.

▣ INSPECTION

- 1) Remove the frame cover.
- 2) Turn the ignition switch “OFF” position.
- 3) Disconnect the combination meter lead wires.
- 4) Connect the battery ⊕ terminal to the O wire of the combination meter and the battery ⊖ terminal to the LY wire of the combination meter directly.

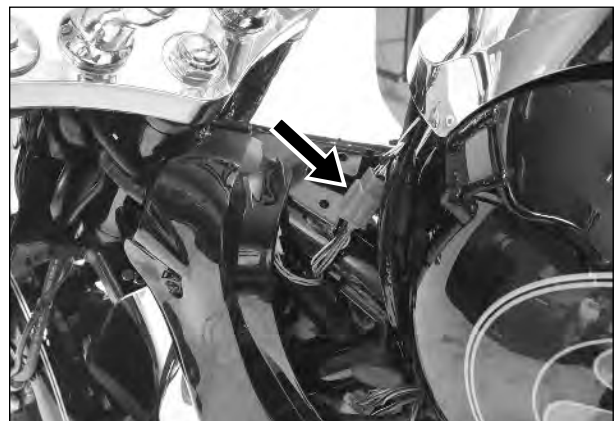

Is the “FI” check lamp come on?

YES	<ul style="list-style-type: none"> ● LY or OB wire open or shorted to ground, or poor Ⓒ3 or Ⓑ15 connection of ECU coupler. ● If wire and connection are OK, intermittent trouble or faulty ECU. ● Recheck each terminal and wire harness for open circuit and poor connection.
NO	Replace the combination meter with a new one.

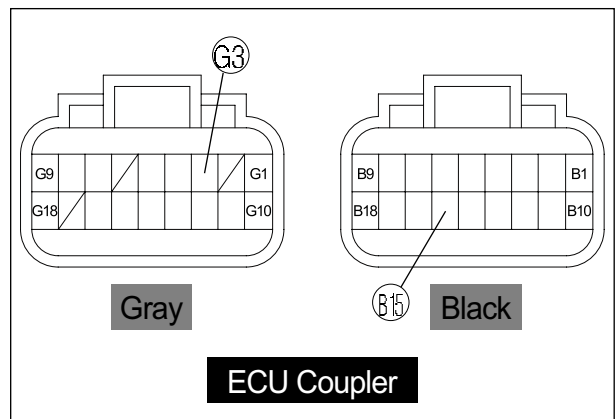

“0850” GP or CLUTCH LEVER SWITCH CIRCUIT MALFUNCTION

LCD (DISPLAY) INDICATION	“FI” CHECK LAMP INDICATION
0850	

DETECTED CONDITION	POSSIBLE CAUSE
<p>☞ Refer to page 4-26</p>	<ul style="list-style-type: none"> ● GP switch circuit open or short. ● GP switch malfunction. ● Clutch lever switch circuit open or short. ● Clutch lever switch malfunction. ● ECU malfunction.

▣ INSPECTION

- 1) Remove the frame cover.
- 2) Turn the ignition switch “OFF” position.
- 3) Check the GP switch and clutch lever switch coupler for loose or poor contacts.
If OK, then measure the GP switch and the clutch lever switch resistance.
- 4) Park the motorcycle on a firm, flat surface vertically.
- 5) Disconnect the GP switch coupler ① and then check the continuity between L wire and ground when gearshift lever is shifted to the neutral state.

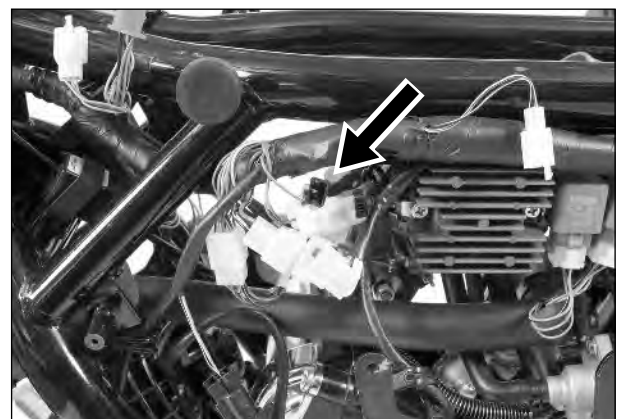
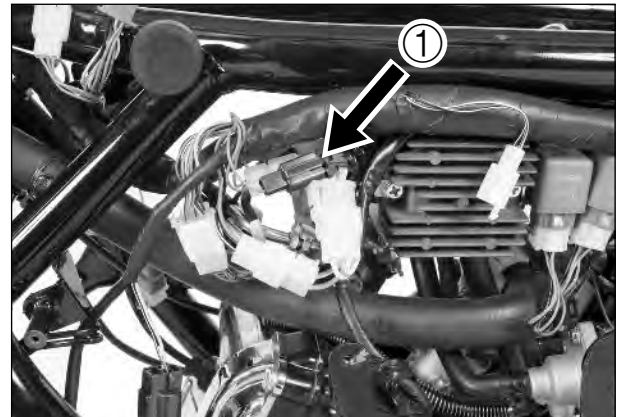

GP switch continuity	0 Ω (L - Ground)
-----------------------------	---------------------

Tester knob indication : Resistance (Ω)

6) Disconnect the clutch lever switch coupler ② and then check the continuity between GR wire and Br wire when the squeezing the clutch lever.

Clutch lever switch continuity	0 Ω (GR - Br)
---------------------------------------	------------------

 Tester knob indication : Resistance (Ω)

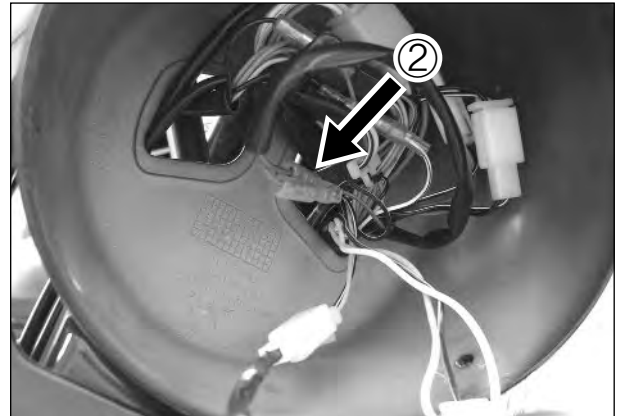

7) Measure the voltage between ⑩ of the ECU and the LY wire of the wiring harness's GP switch coupler, and measure the voltage between ⑩ of the ECU and the GR wire of the wiring harness's clutch lever switch coupler.

If the measurement is out of 0.4 ~ 0.7 V, replace the DIODE #3 with a new one

 Tester knob indication : Diode test (↔)

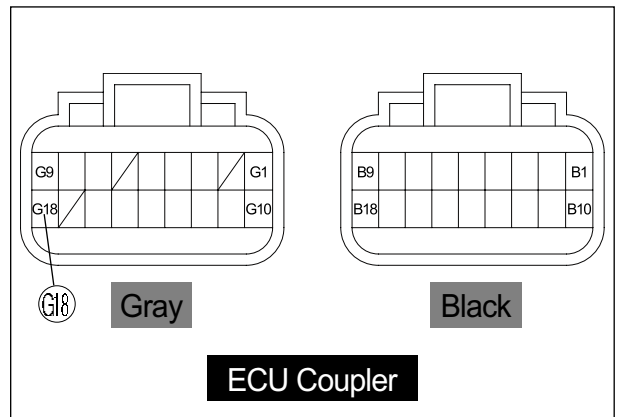

Is OK?

YES	<ul style="list-style-type: none"> ● If wire and connection are OK, intermittent trouble or faulty ECU. ● Recheck each terminal and wire harness for open circuit and poor connection.
NO	Replace the GP switch or Clutch lever switch with a new one.

SENSORS

⊙ PICK-UP COIL INSPECTION

The pick-up coil ① is installed in the magneto cover.
(Refer to page 4-41)

⊙ PICK-UP COIL REMOVAL AND INSTALLATION

- Remove the magneto cover.
- Install the magneto cover in the reverse order of removal.

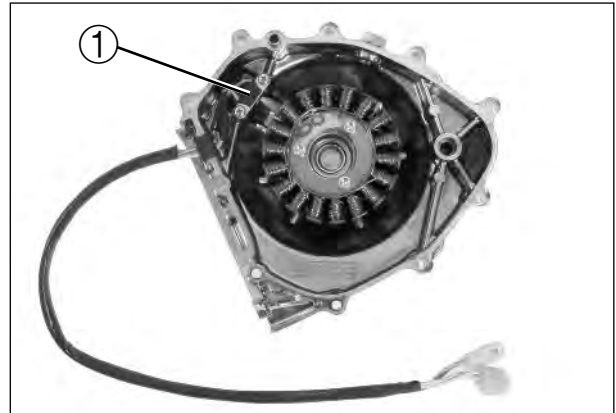

⊙ IAP SENSOR INSPECTION

The intake air pressure (IAP) sensor ② is installed at the left side of the throttle body.
(Refer to page 4-29)

⊙ IAP SENSOR REMOVAL AND INSTALLATION

- Remove the fuel tank.
- Remove the IAP sensor from the left side of the throttle body.
- Install the IAP sensor in the reverse order of removal.

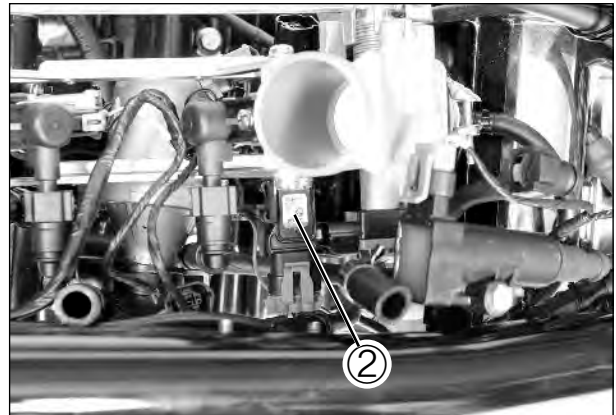

⊙ TP SENSOR INSPECTION

The throttle position (TP) sensor ③ is installed at the left side of the throttle body. (Refer to page 4-35)

⊙ TP SENSOR REMOVAL AND INSTALLATION

⚠ CAUTION

Never remove or adjust the TP sensor.

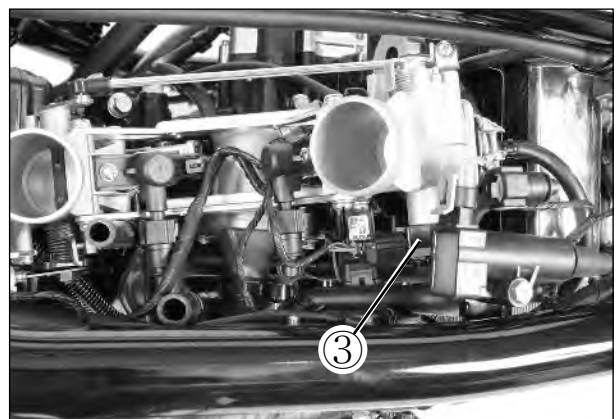

⊙ WT SENSOR INSPECTION

The water temperature (WT) sensor ① is installed at the rear side of the thermostat case.

(Refer to page 4-33)

⊙ WT SENSOR REMOVAL AND INSTALLATION

- Remove the WT sensor.
- Install the WT sensor in the reverse order of removal.

 WT sensor : 5 ~ 8 N · m (0.5 ~ 0.8 kgf · m)

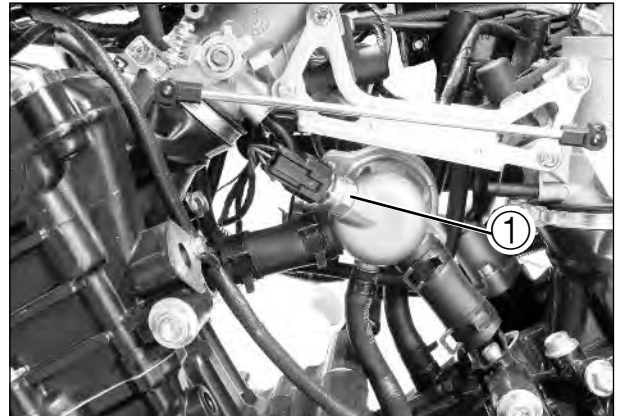

⊙ IAT SENSOR INSPECTION

The intake air temperature (IAT) sensor ② is installed at the downside of the air cleaner case.

(Refer to page 4-31)

⊙ IAT SENSOR REMOVAL AND INSTALLATION

- Remove the fuel tank.
- Remove the IAT sensor from the air cleaner case.
- Install the IAT sensor in the reverse order of removal.

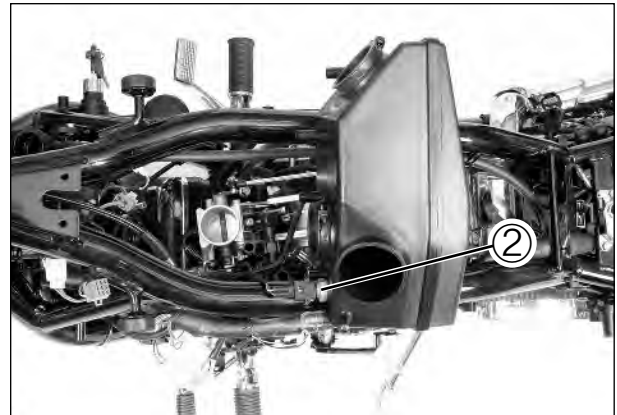

⊙ RO SWITCH INSPECTION, REMOVAL AND INSTALLATION

The roll over (RO) switch ③ is located in the downside of the fuel tank mounting bolts.

- Remove the front seat.
- Remove the RO switch from the frame.
- Install the RO switch in the reverse order of removal.

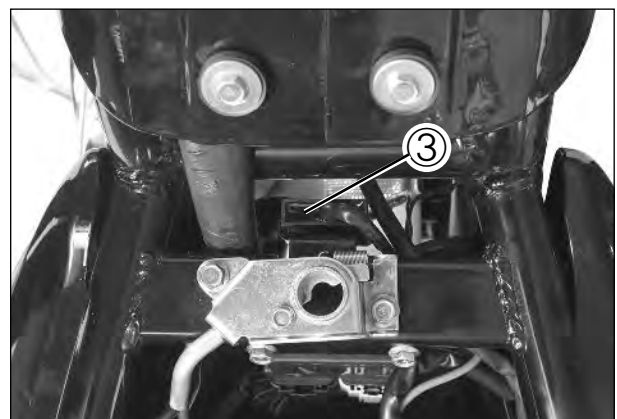

FUEL SYSTEM AND THROTTLE BODY

CONTENTS

FUEL SYSTEM	5- 1
REMOVAL AND DISASSEMBLY	5- 2
REASSEMBLY AND INSTALLATION	5- 3
FUEL PRESSURE OF FUEL PUMP INSPECTION	5- 4
FUEL PUMP RELAY INSPECTION	5- 4
FUEL MESH FILTER INSPECTION AND CLEANING	5- 5
FUEL GAUGE INSPECTION	5- 5
THROTTLE BODY	5- 6
REMOVAL	5- 7
CLEANING	5- 8
INSPECTION	5- 8
INSTALLATION	5- 8

CAUTION

Gasoline must be handled carefully in an area well ventilated and away from fire or spark.

FUEL SYSTEM

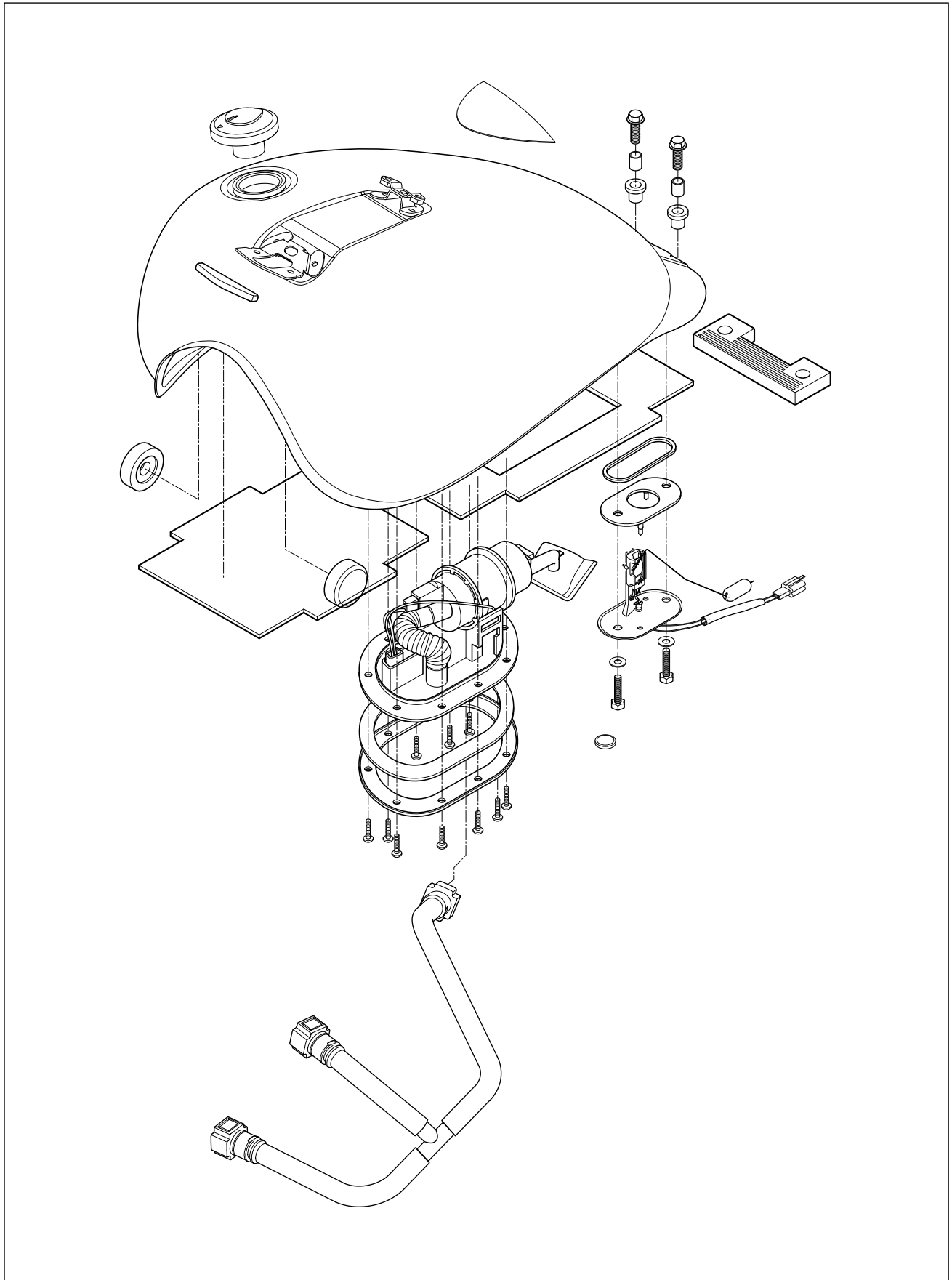

REMOVAL AND DISASSEMBLY

- Remove the front seat.

WARNING

Gasoline is very explosive.
Extreme care must be taken.



- Remove the fuel tank mounting bolts and take off the hooks.

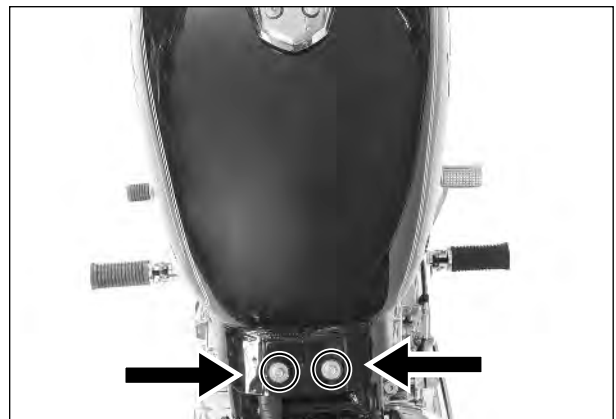

- Disconnect the fuel gauge coupler ①.

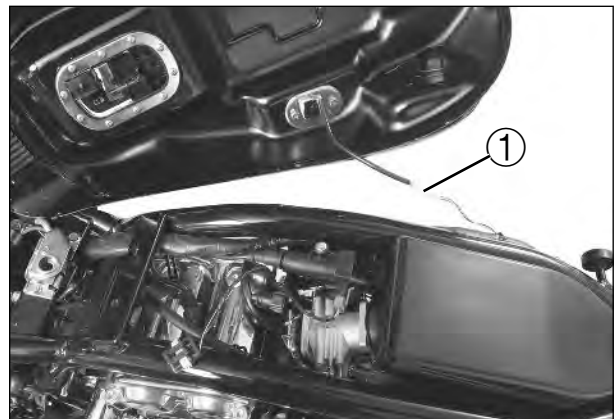

- Remove the fuel pump coupler ②.
- Remove the fuel injector hose.

CAUTION

After disconnecting the fuel injector hose, insert a blind plug into the end to stop fuel leakage.



5-3 FUEL SYSTEM AND THROTTLE BODY

- Remove the fuel tank rearward.

CAUTION

As gasoline leakage may occur in this operation, keep away from fire and sparks.

- Remove the fuel pump assembly ① by removing its mounting bolts diagonally.

WARNING

- ❖ Gasoline is highly flammable and explosive.
- ❖ Keep heat, spark and flame away.

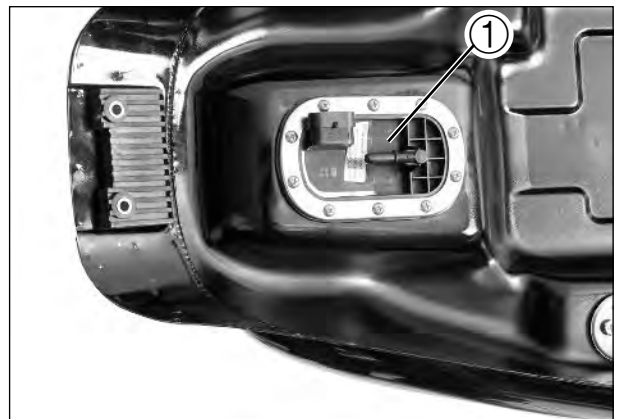

- Remove the fuel gauge ②.

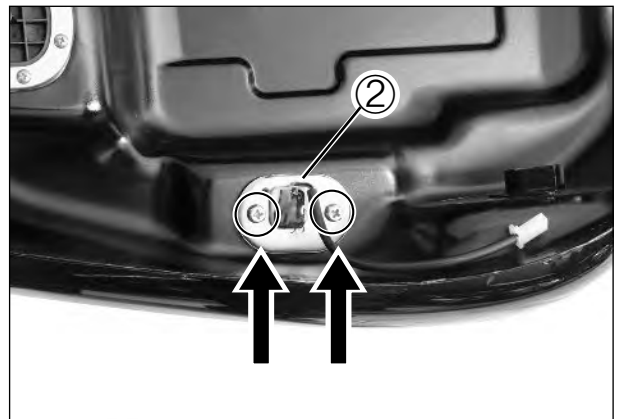

REASSEMBLY AND INSTALLATION

Reassembly and installation the fuel tank in the reverse order of removal and disassembly.

- When installing the fuel pump assembly, first tighten all the fuel pump assembly mounting bolts lightly in diagonal stages, and then tighten them in the above tightening order.

NOTE

Apply a small quantity of the **THREAD LOCK "1324"** to the thread portion of the fuel pump mounting bolt.

 **THREAD LOCK "1324"**

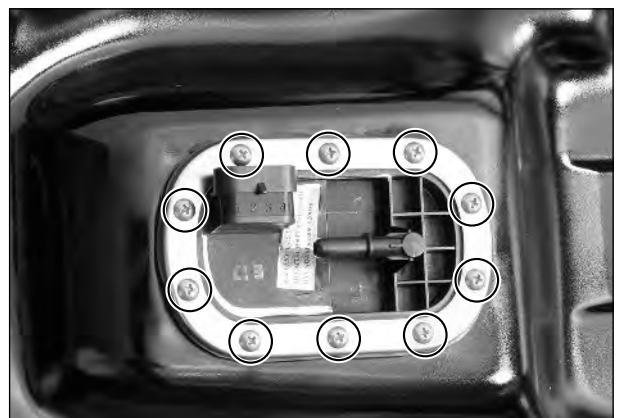

FUEL PRESSURE OF FUEL PUMP INSPECTION

- Remove the seat.
- Place a rag under the fuel injector hose.
- Disconnect the fuel injector hose from the fuel hose joint.
- Install the special tool between the fuel tank and fuel hose joint.



Fuel pump pressure gauge

: 09915-54510

Turn the ignition switch "ON" position and check the fuel pressure of the fuel pump.

Fuel pressure of fuel pump

Approx. 2.25 ~ 2.50 kgf/cm²
(220 ~ 245 kPa, 32.0 ~ 35.6 psi)

If the fuel pressure is lower than the specification, inspect the following items :

- * Fuel hose leakage
- * Clogged fuel filter
- * Pressure regulator
- * Fuel pump

If the fuel pressure is higher than the specification, inspect the following items :

- * Fuel pump check valve
- * Pressure regulator



WARNING

- Before removing the special tool, turn the ignition switch to "OFF" position and release the fuel pressure slowly.
- Gasoline is highly flammable and explosive. Keep heat, sparks and flame away.

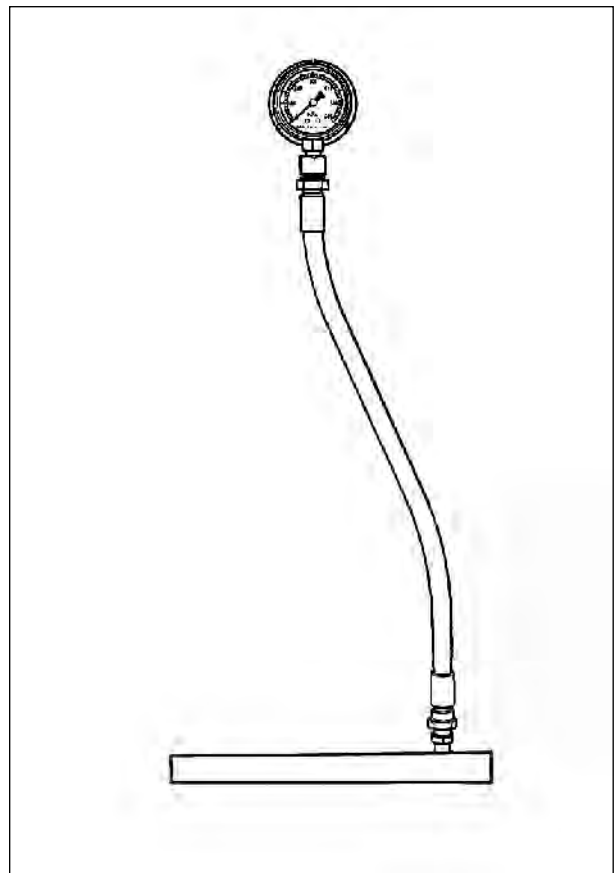

FUEL PUMP RELAY INSPECTION

Fuel pump relay is located the left side of the frame.

- Remove the fuel tank lower decoration cover.
- Remove the fuel pump relay ①.

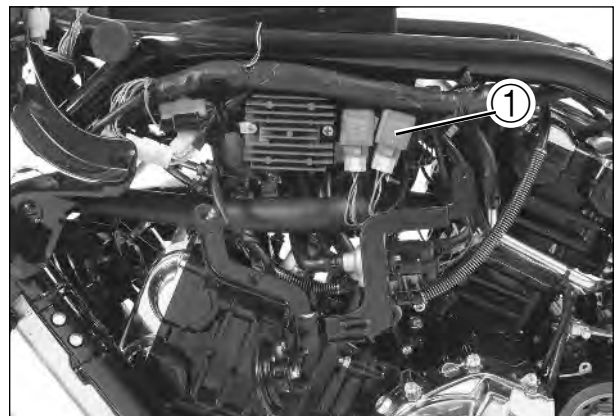

5-5 FUEL SYSTEM AND THROTTLE BODY

First, check the insulation between ① and ② terminals with pocket tester. Then apply 12 volts to ③ and ④ terminals, ⊕ to ③ and ⊖ to ④, and check the continuity between ① and ②.

If there is no continuity, replace it with a new one.

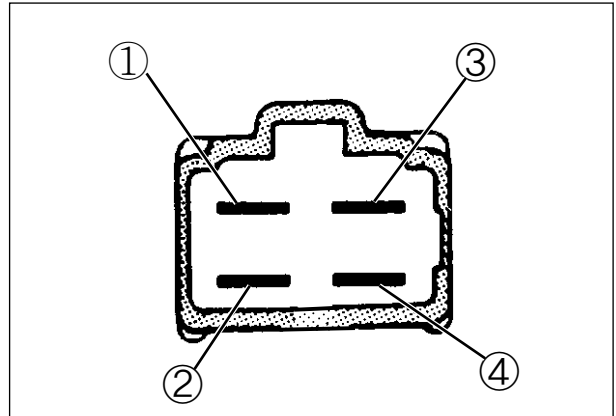

FUEL MESH FILTER INSPECTION AND CLEANING

- If the fuel mesh filter is clogged with sediment or rust, fuel will not flow smoothly and loss in engine power may result.
- Blow the fuel mesh filter with compressed air.

NOTE

If the fuel mesh filter is clogged with many sediment or rust, replace the fuel filter cartridge with a new one.

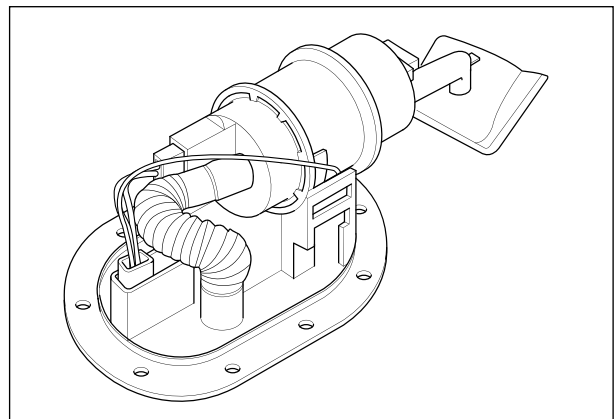

FUEL GAUGE INSPECTION

- Measure resistance between the terminals when float is at the position instead below.

Fuel float position	Resistance between terminals
F	Approx. 90 ~ 100 Ω
1/2	Approx. 55 Ω
E	Approx. 4 ~ 15 Ω

- If the resistance measured is out of the specification, replace the gauge with a new one.
- Inspect the fuel level meter.

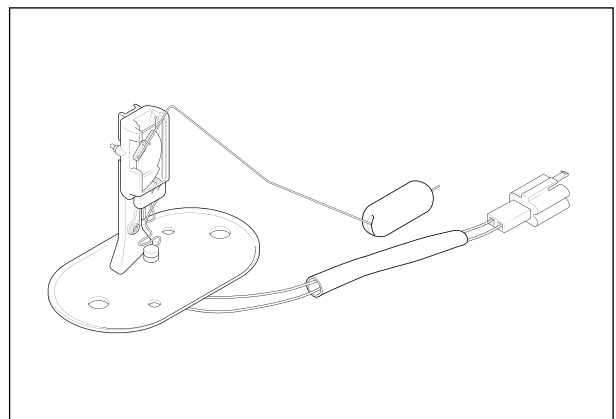

THROTTLE BODY

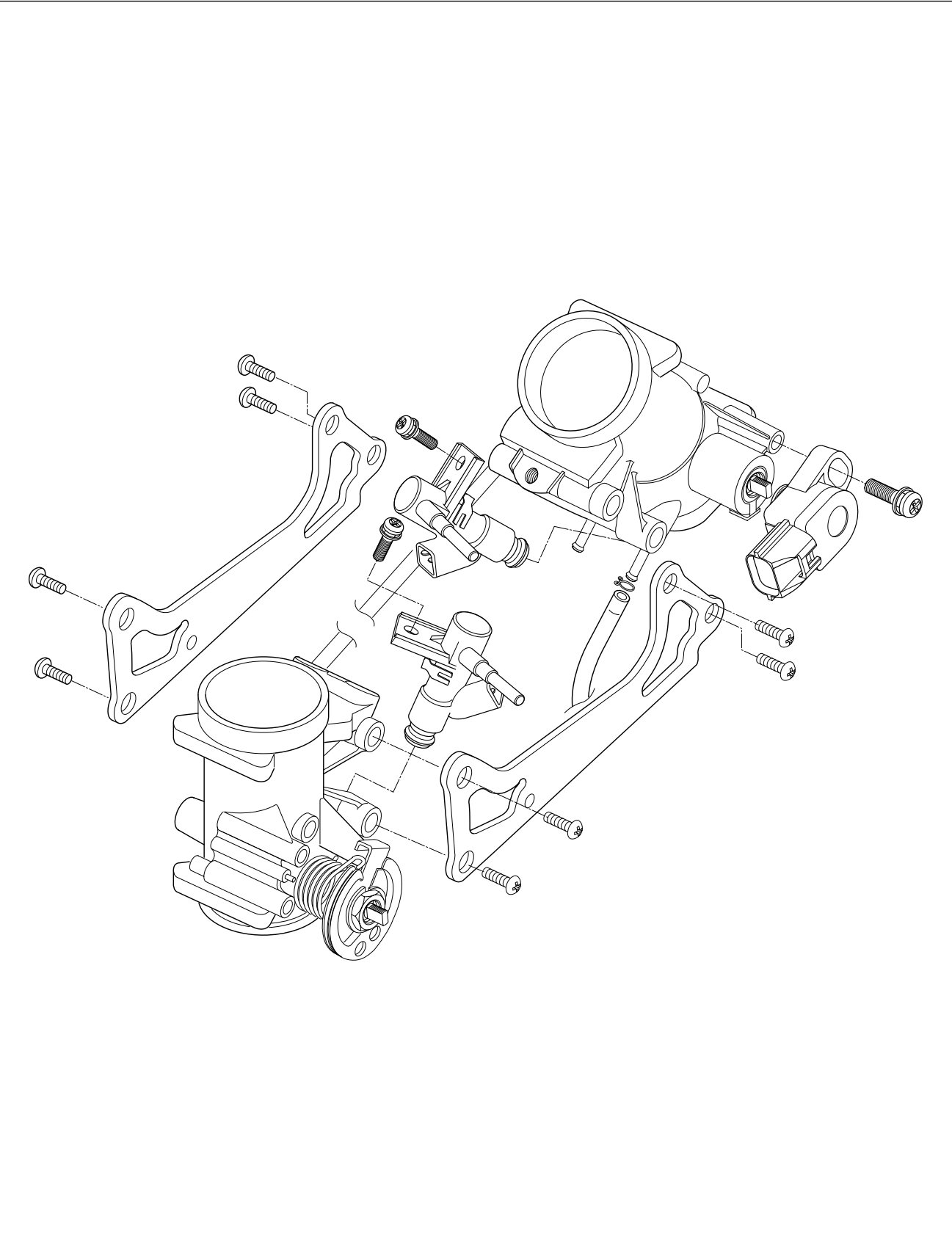

5-7 FUEL SYSTEM AND THROTTLE BODY

REMOVAL

- Remove the fuel tank.
- Disconnect the fuel hoses.
- Remove the all couplers to related the throttle body.

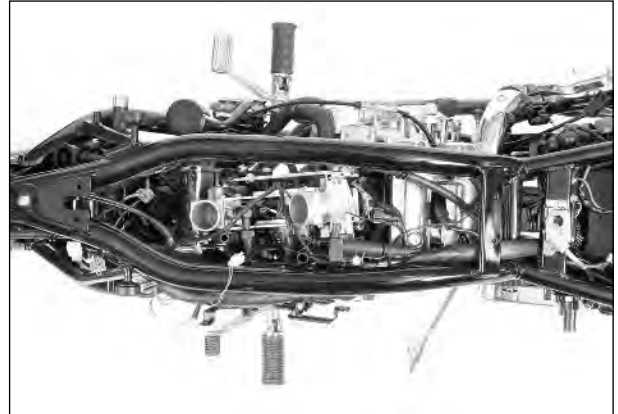

- Loosen the throttle body clamp screws.

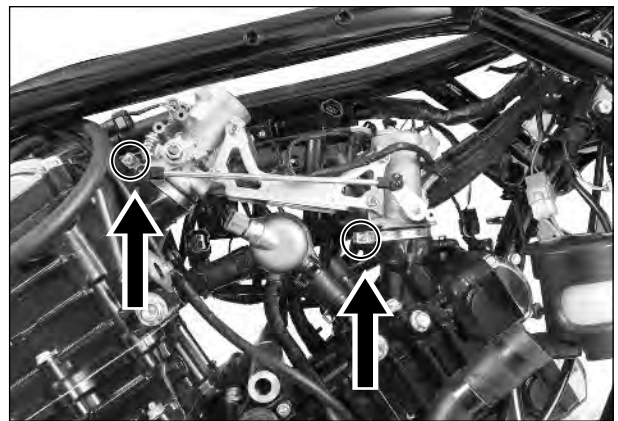

- Remove the air cleaner chamber.
- Disconnect the throttle cables from their drum.
- Dismount the throttle body assembly.

 **CAUTION**

- ❖ Be careful not to damage the throttle cable bracket when dismounting or remounting the throttle body assembly.
- ❖ After disconnecting the throttle cables, do not snap the throttle valve from full open to full close. It may cause damage to the throttle valve and throttle body.



CLEANING

- Clean all passageways with a spray-type throttle body cleaner and blow dry with compressed air.

WARNING

Some throttle body cleaning chemicals, especially dip-type soaking solutions, are very corrosive and must be handled carefully. Always follow the chemical manufacturer's instructions on proper use, handling and storage.

CAUTION

Do not use wire to clean passageways. Wire can damage passageways. If the components cannot be cleaned with a spray cleaner it may be necessary to use a dip-type cleaning solution and allow them to soak. Always follow the chemical manufacturer's instructions for proper use and cleaning of the throttle body components. Do not apply throttle body cleaning chemicals to the rubber and plastic materials.

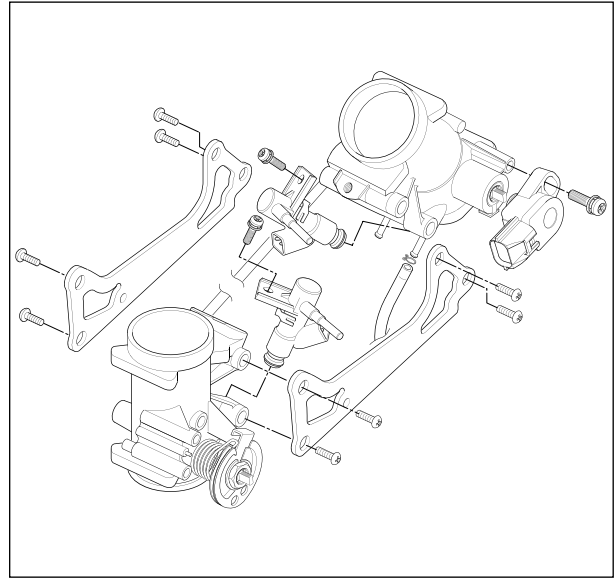

INSPECTION

- Check following items for any damage or clogging.

* O-ring	* Throttle body
* Injector cushion seal	* Fuel injector
* Throttle valve	* Vacuum hose
* Intake pipe	
* Throttle shaft bushing and seal	

Check fuel injector filter for evidence of dirt and contamination. If present, clean and check for presence of dirt in the fuel lines and fuel tank.

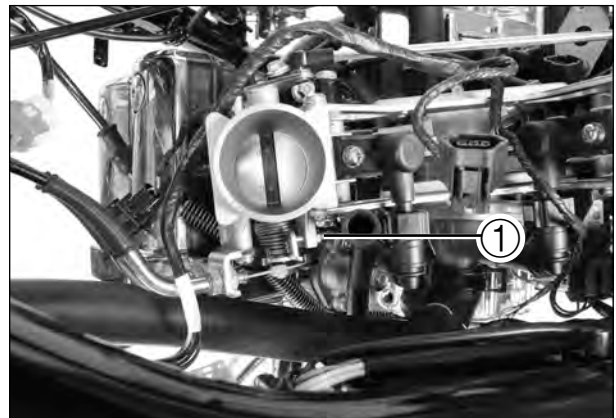

INSTALLATION

Installation is in the reverse order of removal. Pay attention to the following points :

CAUTION

Never operate the idle screw ① to avoid variations of the carburetion setting.

- Connect the throttle cable to the throttle cable drum.
- Adjust the throttle cable play with the cable adjusters.

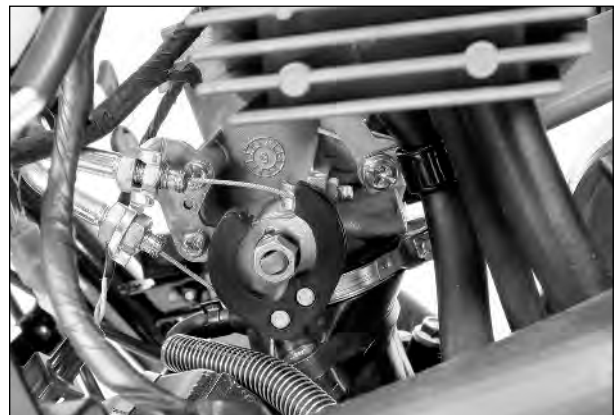

COOLING SYSTEM

CONTENTS

ENGINE COOLANT	6- 1
COOLING CIRCUIT	6- 2
RADIATOR	6- 2
COOLING FAN	6- 5
COOLING FAN THERMO-SWITCH	6- 6
WATER TEMPERATURE SENSOR	6- 8
THERMOSTAT	6- 9
WATER PUMP	6-11

ENGINE COOLANT

At the time of manufacture, the cooling system is filled with a 50 : 50 mixture of distilled water and ethylene glycol anti-freeze.

This 50 : 50 mixture will provide the optimum corrosion protection and excellent heat protection, and will protect the cooling system from freezing at temperatures above $-31\text{ }^{\circ}\text{C}$ ($-24\text{ }^{\circ}\text{F}$).

If the motorcycle is to be exposed to temperatures below $-31\text{ }^{\circ}\text{C}$ ($-24\text{ }^{\circ}\text{F}$), this mixing ratio should be increased up to 55% or 60% according to the figure.

Anti-freeze density	Freezing point
50%	$-31\text{ }^{\circ}\text{C}$ ($-24\text{ }^{\circ}\text{F}$)
55%	$-40\text{ }^{\circ}\text{C}$ ($-40\text{ }^{\circ}\text{F}$)
60%	$-55\text{ }^{\circ}\text{C}$ ($-67\text{ }^{\circ}\text{F}$)

 CAUTION	
❖ Use a high quality ethylene glycol base anti-freeze, mixed with distilled water. Do not mix an alcohol base anti-freeze and different brands of anti-freeze.	
❖ Do not put in more than 60% anti-freeze or less than 50%. (Refer to Right figure.)	
❖ Do not use a radiator anti-leak additive.	

50% Engine coolant including reserve tank capacity	
Anti-freeze	0.8 ℓ
Water	0.8 ℓ

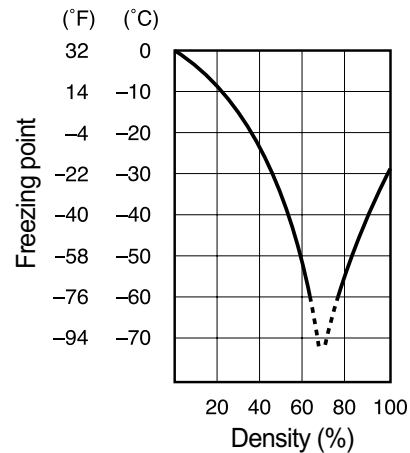

Fig.1 Engine coolant density-freezing point curve.

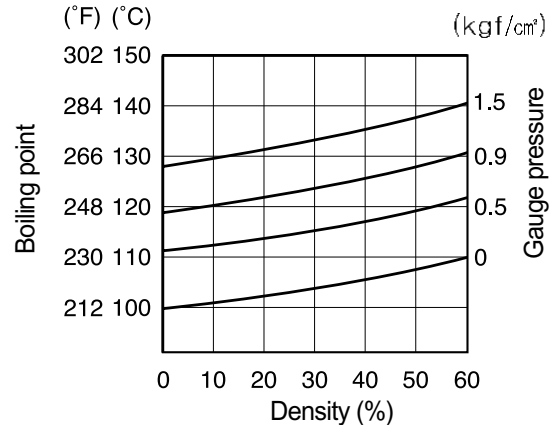
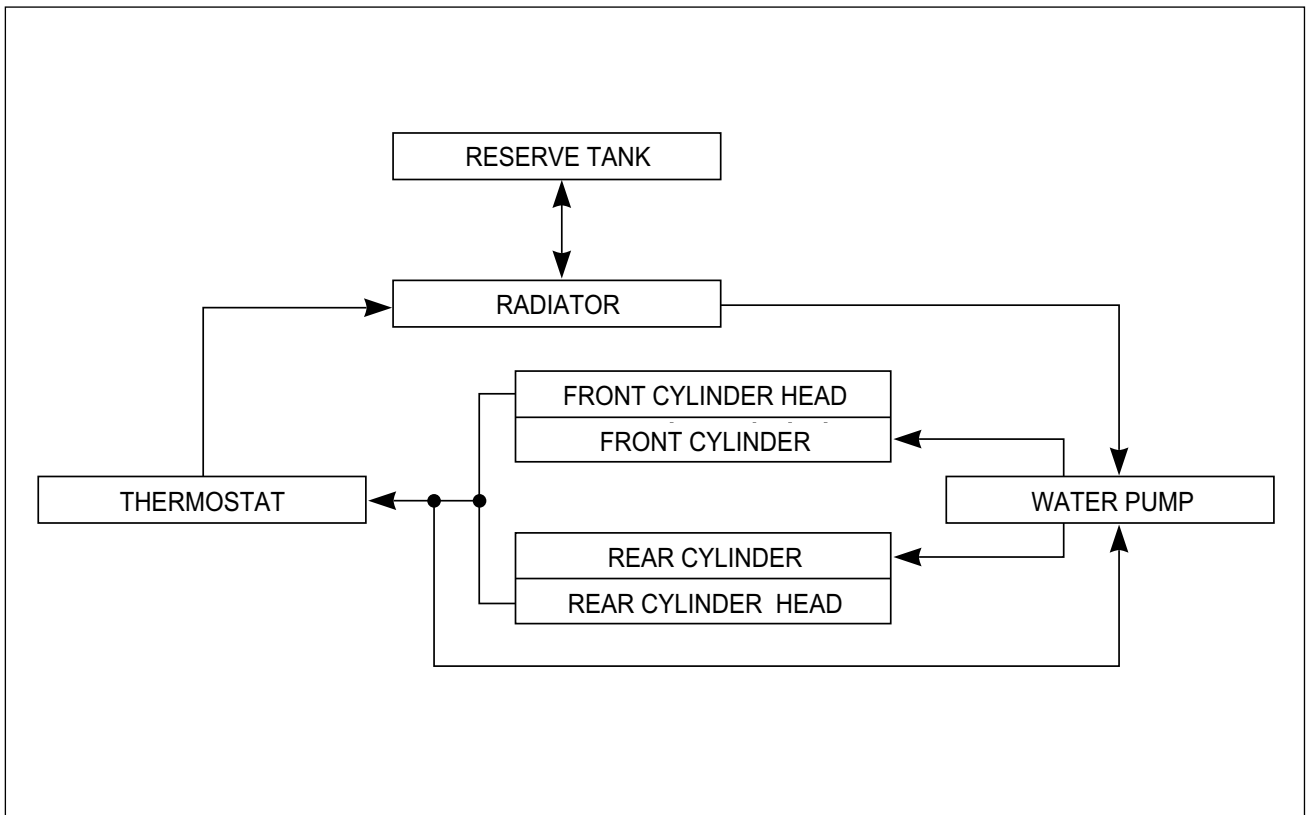

Fig.2 Engine coolant density-boiling point curve.

WARNING

- ❖ You can be injured by scalding fluid or steam if you open the radiator cap when the engine is hot. After the engine cools, wrap a thick cloth around cap and carefully remove the cap by turning it a quarter turn to allow pressure to escape and then turn the cap all the way off.
- ❖ The engine must be cool before servicing the cooling system.
- ❖ Coolant is harmful ;
 - * If it comes in contact with skin or eyes, flush with water.
 - * If swallowed accidentally, induce vomiting and call physician immediately.
 - * Keep it away from children.

COOLING CIRCUIT



RADIATOR

REMOVAL

- Drain engine coolant. (Refer to page 2-25)
- After removing the two mounting bolts ②, remove the right frame head cover ①.
- Remove the radiator cap case bolt ③.

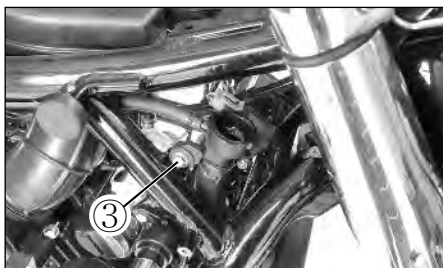

- Remove the radiator cover by the four mounting bolts.
- Disconnect the radiator outlet hose ④.

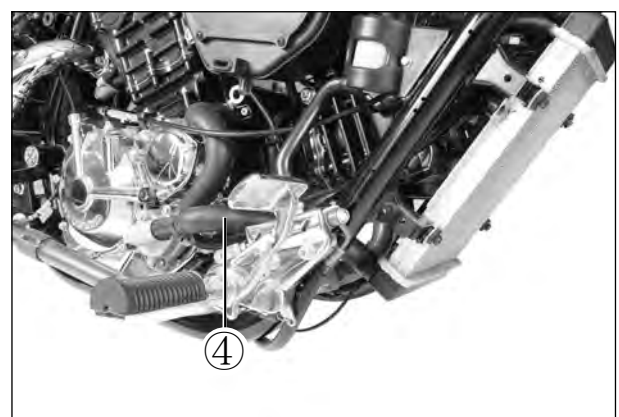
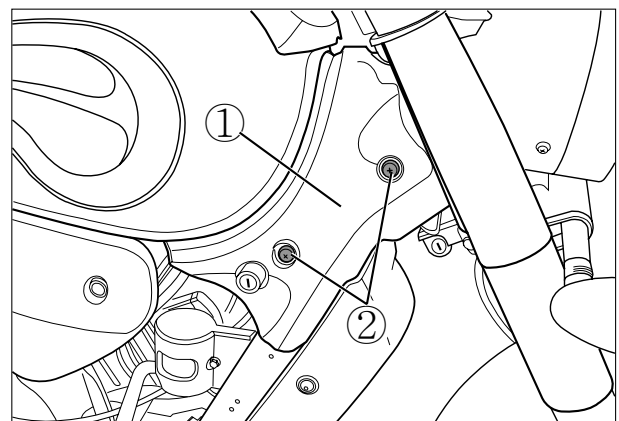
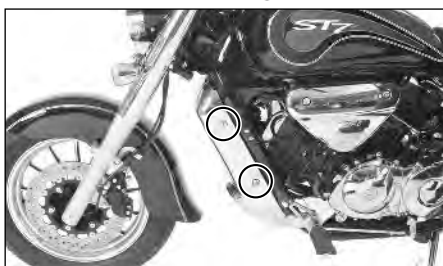

6-3 COOLING SYSTEM

- Disconnect the cooling fan thermo-switch lead wire coupler ①.
- Disconnect the radiator inlet hose ②.

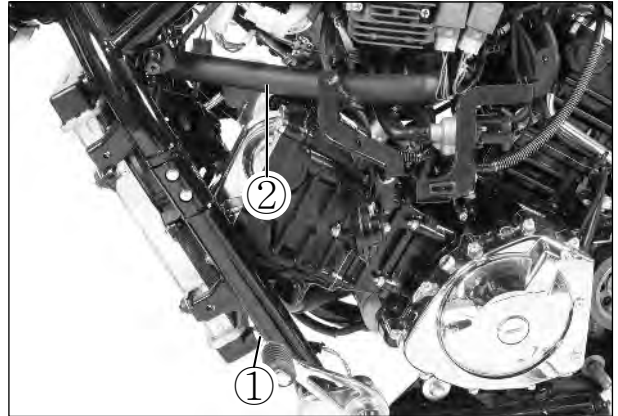

- Disconnect reserve tank hose ③.
- Disconnect the cooling fan motor lead wire coupler ④.

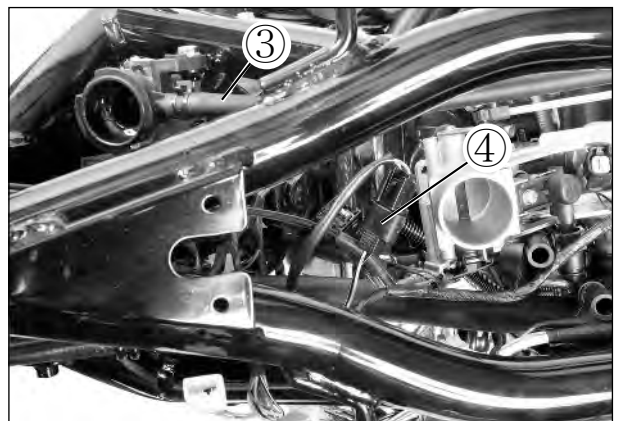

- Remove the radiator by the mounting bolts.

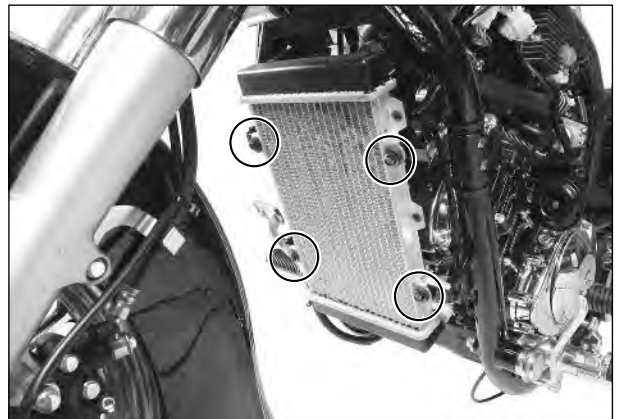

⊙ INSPECTION AND CLEANING

Road dirt or trash stuck to the fins must be removed. Use of compressed air is recommended for this cleaning.

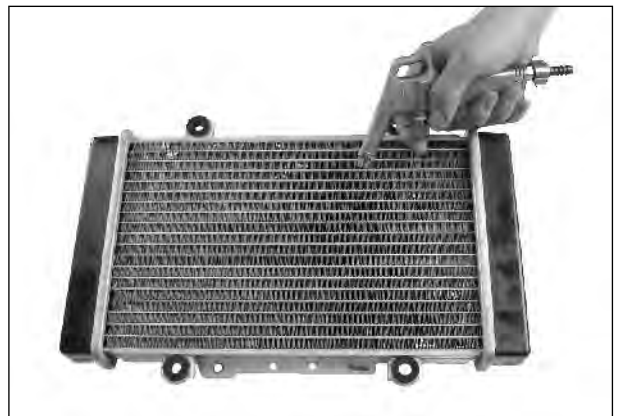

Fins bent down or dented can be repaired by straightening them with the blade of a small screwdriver.

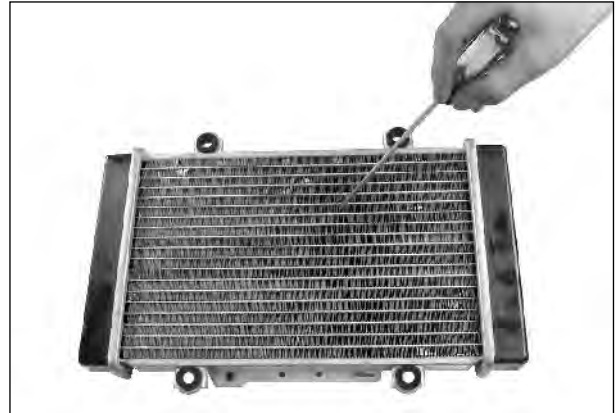

⊙ INSPECTION OF WATER HOSE

Any water hose found in a cracked condition or flattened or water leaked must be replaced.
Any leakage from the connecting section should be corrected by proper tightening.



⊙ REMOUNTING

The radiator reassembly can be performed in the reverse order of disassembly procedures.
However, the following points must be observed in the reassembly operation.

- Install the radiator with the specified torque.



Radiator mounting bolt

: 8 ~ 12 N · m (0.8 ~ 1.2 kgf · m)

- * Pour engine coolant Refer to page 2-25
- * Bleed air from the cooling circuit Refer to page 2-26

COOLING FAN

⊙ INSPECTION

- Remove the radiator cover. (Refer to page 6-2)
 - Disconnect the cooling fan motor lead wire coupler ① and its thermo-switch lead wire coupler ②.
- Test the cooling fan motor for load current with an ammeter connected as shown in the illustration.

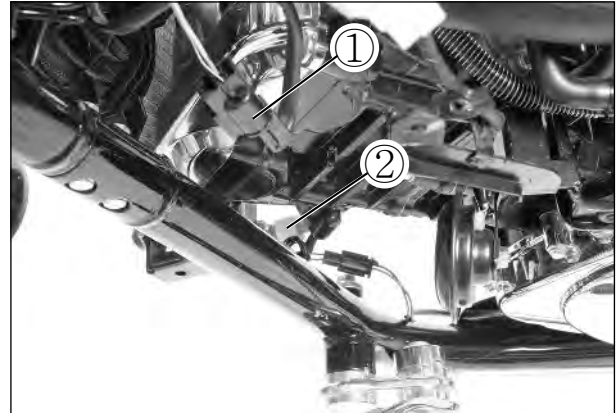

The voltmeter is for making sure that the battery applies 12 volts to the motor. With the motor with electric motor fan running at full speed, the ammeter should be indicating not more than 5 amperes. If the fan motor does not turn, replace the motor assembly with a new one.

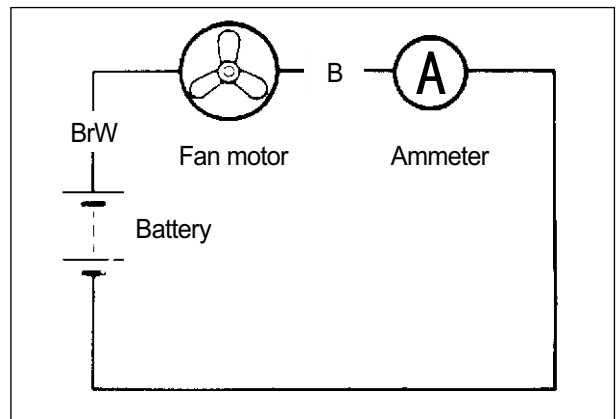

NOTE

When making above test, it is not necessary to remove the cooling fan.

⊙ REMOVAL

- Drain engine coolant. (Refer to page 2-25)
- Remove the radiator cover.
- Remove the radiator. (Refer to page 6-3)
- Disconnect the cooling fan thermo-switch ③.
- Remove the cooling fan.

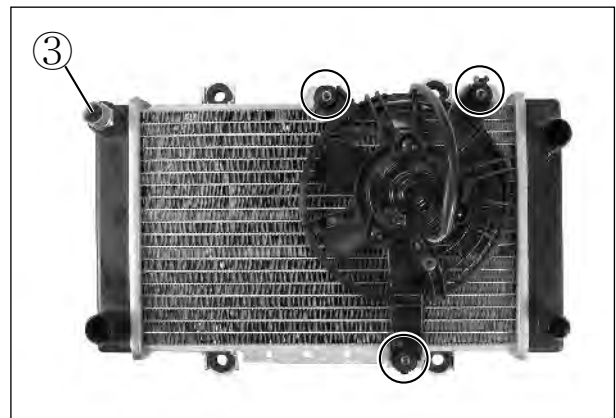

⊙ INSTALLATION

- Install the cooling fan to the radiator.



Cooling fan mounting bolt

: 8 ~ 12 N · m (0.8~1.2 kgf · m)

Cooling fan motor mounting bolt

: 8 N · m (0.8 kgf · m)

- Install the radiator.
- Route the radiator hoses properly.
- Pour engine coolant. (Refer to page 2-25)
- Bleed air from the cooling circuit. (Refer to page 2-26)
- Install the radiator cover.

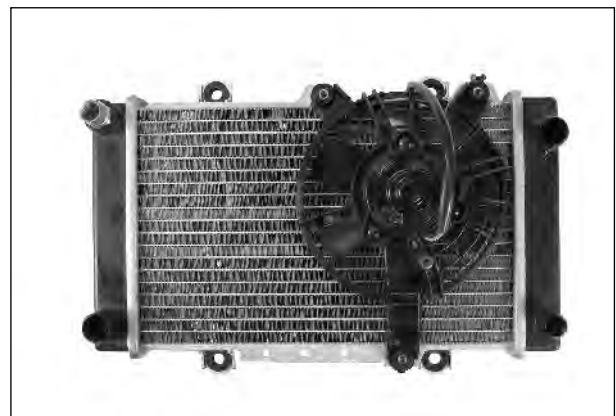

COOLING FAN THERMO-SWITCH

The cooling fan is secured behind the radiator by three bolts and is automatically controlled by the thermo-switch. The thermo-switch remains open when the temperature of the engine coolant is low, but closes when the temperature reaches approximately 78°C (172°F) setting the cooling fan in motion.

REMOVAL

- Drain engine coolant. (Refer to page 2-25)
- Remove the radiator cover. (Refer to page 6-2)
- Disconnect the cooling fan thermo-switch lead wire coupler ①.
- Remove the cooling fan thermo-switch ②.

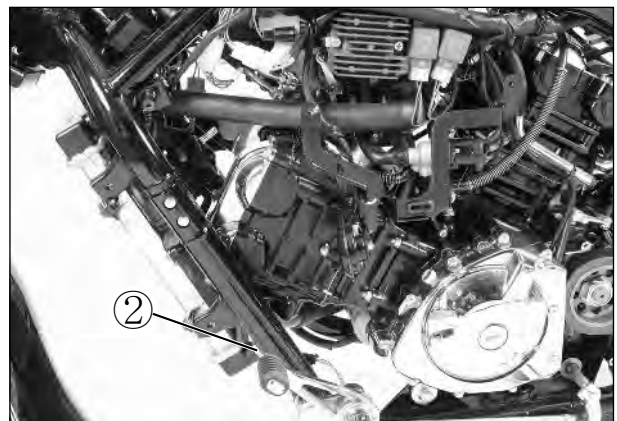
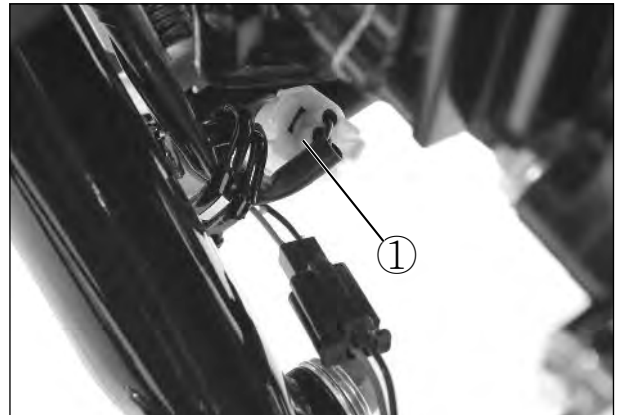

INSPECTION

- Check the thermo-switch closing or opening temperatures by testing it at the bench as shown in the figure. Connect the thermo-switch ③ to a circuit tester and place it in the OIL contained in a pan, which is placed on a stove.
- Heat the oil to raise its temperature slowly and read the column thermometer ④ when the switch closes or opens.

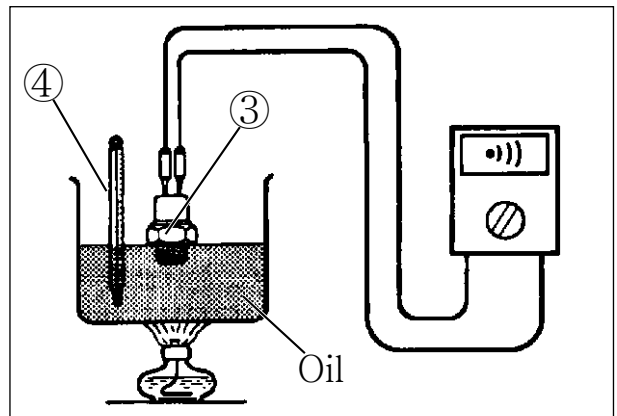

Cooling fan thermo-switch operating temperature	Standard
ON → OFF	Over 88 °C (190 °F)
OFF → ON	Approx. 95 °C (203 °F)

 Multi circuit tester set : 09900-25008

CAUTION

- ❖ Take special care when handling the thermo-switch. It may cause damage if it gets a sharp impact.
- ❖ Do not contact the cooling fan thermo-switch ③ and the column thermometer ④ with a pan.

● INSTALLATION

Install the cooling fan thermo-switch in the reverse order of removal.

Pay attention to the following points :

- Install a new O-ring ① and apply engine coolant to the O-ring.
- Tighten the cooling fan thermo-switch to the specified torque.



Cooling fan thermo-switch

: 13 N · m (1.3 kgf · m)

- Pour engine coolant. (Refer to page 2-25)
- Bleed air from the cooling circuit. (Refer to page 2-26)
- Install the radiator cover.

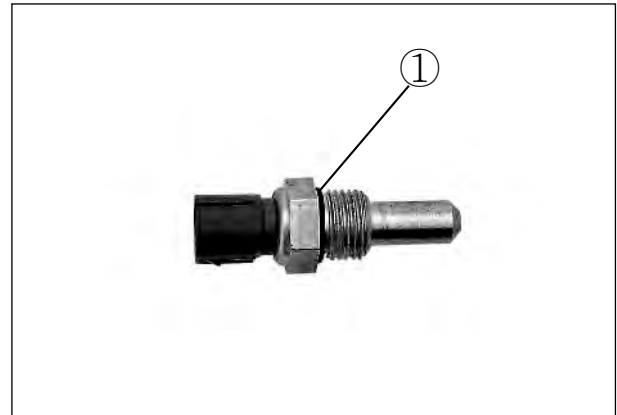

WATER TEMPERATURE SENSOR

REMOVAL

- Drain engine coolant. (Refer to page 2-25)
- Remove the front seat. (Refer to page 8-1)
- Remove the fuel tank. (Refer to page 5-2)
- Remove the throttle body. (Refer to page 5-7)
- Disconnect the WT (Water Temperature) sensor lead wire coupler ①.
- Place a rag under the sensor and remove the WT sensor ②.

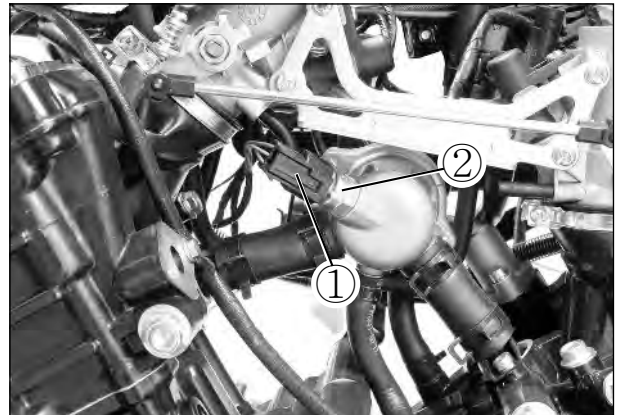

INSPECTION

- Check the engine coolant temperature by testing it at the bench as shown in the figure. Connect the WT sensor ② to a circuit tester and place it in the WATER contained in a pan, which is placed on a stove.
- Heat the water to raise its temperature slowly and read the column thermometer ③ and the ohmmeter.

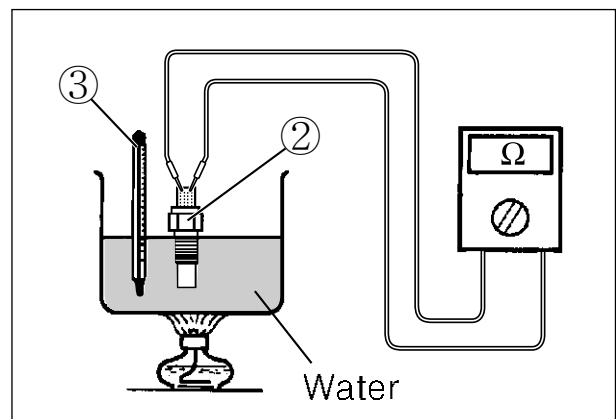

WT sensor resistance	
Engine Coolant Temp.	Resistance (To ECU)
-40 °C (-40 °F)	Approx. 48.140 KΩ
0 °C (32 °F)	Approx. 5.790 KΩ
20 °C (68 °F)	Approx. 2.450 KΩ
40 °C (104 °F)	Approx. 1.148 KΩ
60 °C (140 °F)	Approx. 0.586 KΩ
80 °C (176 °F)	Approx. 0.322 KΩ
120 °C (248 °F)	Approx. 0.1163 KΩ

 **Multi circuit tester set : 09900-25008**

If the resistance noted to show infinity or too much different resistance value, replace the WT sensor with a new one.

CAUTION

- ❖ Take special care when handling the WT sensor. It may cause damage if it gets a sharp impact.
- ❖ Do not contact the WT sensor ② and the column thermometer ③ with a pan.

INSTALLATION

Install the WT sensor in the reverse order of removal. Pay attention to the following points :

- Install a new O-ring ④ and apply engine coolant to the O-ring.
- Tighten the WT sensor to the specified torque.

 **WT sensor : 5 ~ 8 N · m (0.5 ~ 0.8 kgf · m)**

- Pour engine coolant. (Refer to page 2-25)
- Bleed air from the cooling circuit. (Refer to page 2-26)



THERMOSTAT

REMOVAL

- Drain engine coolant. (Refer to page 2-25)
- Place a rag under the thermostat case.
- Remove the thermostat case cap.

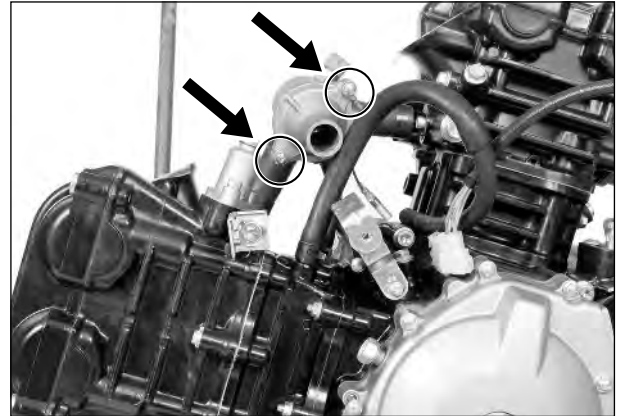

- Remove the thermostat ①.



INSPECTION

Inspect the thermostat pellet for signs of cracking. Test the thermostat at the bench for control action, in the following manner.

- Pass a string between flange, as shown in the photograph.
- Immerse the thermostat in the WATER contained in a beaker, as shown in the illustration. Note that the immersed thermostat is in suspension. Heat the water by placing the beaker on a stove ② and observe the rising temperature on a thermometer ③.
- Read the thermometer just when opening the thermostat.

This reading, which is the temperature level at which the thermostat valve begins to open, should be within the standard value.

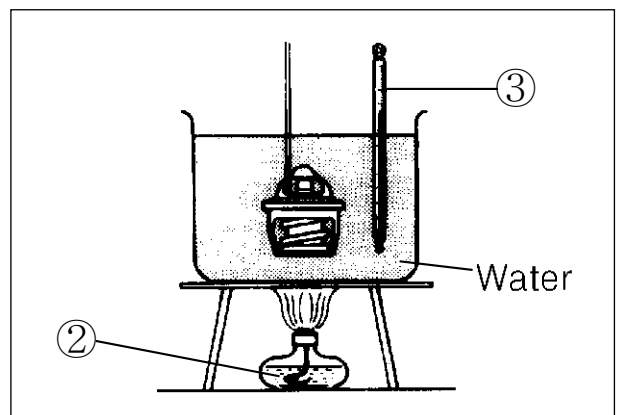

Thermostat valve operation temperature	Standard
Valve opening	88 °C (190°F)
Valve full open	100 °C (212°F)
Valve closing	83 °C (181°F)

- Keep on heating the water to raise its temperature.
- Just when the water temperature reaches specified value, the thermostat valve should have lifted by at least 8.0 mm (0.32 in).

Thermostat valve lift [Ⓐ]	Standard
	Over 8.0 mm at 100 °C (Over 0.32 in at 212°F)

- A thermostat failing to satisfy either of the two requirements, start-to-open temperature and valve lift, must be replaced with a new one.

⊙ INSTALLTION

Install the thermostat in the reverse order of removal.
Pay attention to the following points :

- Apply engine coolant to the rubber seal on the thermostat.
- Install the thermostat.

NOTE

The jiggle valve ^① of the thermostat faces upside.

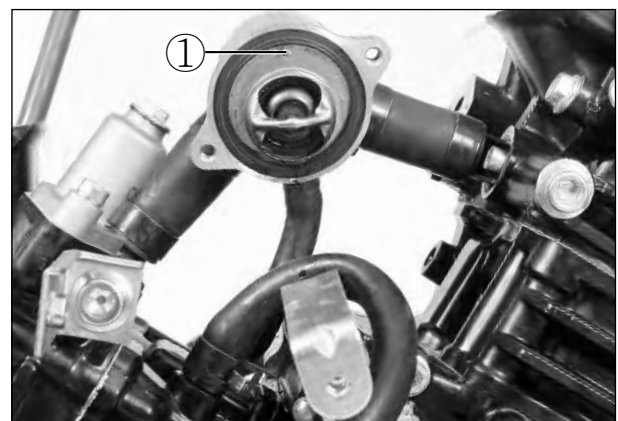
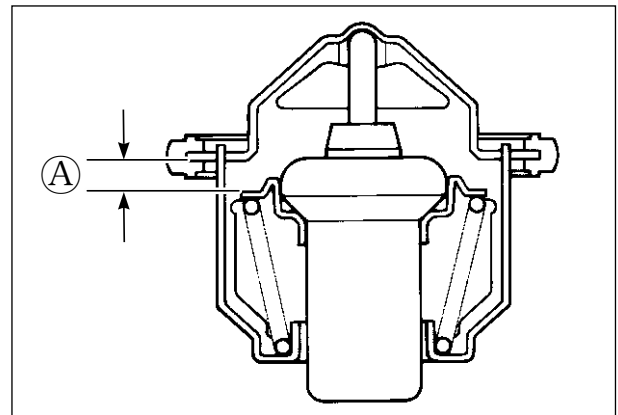

- Install the thermostat case cap ^②.

NOTE

The rib ^③ of the thermostat case cap should be faced upward.

- Tighten the thermostat case cap bolts to the specified torque.



Thermostat case cap bolt

: 10 N · m (1.0 kgf · m)

- Pour engine coolant. (Refer to page 2-25)
- Bleed air from the cooling circuit.
(Refer to page 2-26)

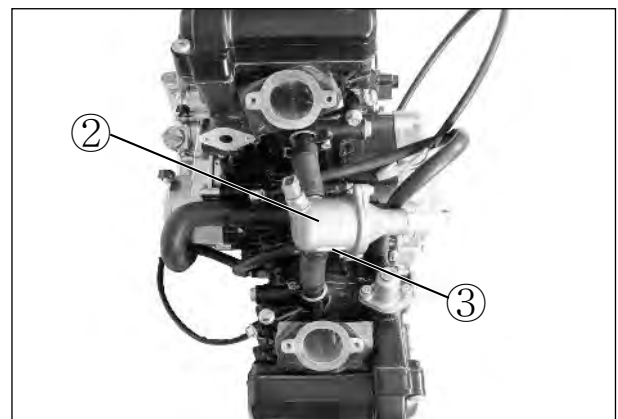

WATER PUMP

○ REMOVAL AND DISASSEMBLY

- Drain engine coolant. (Refer to page 2-25)
- Drain engine oil. (Refer to page 2-12)
- Remove the water pump cover ①.
- Remove the radiator outlet hose cover ②.
- Disconnect the water hoses ③, ④, ⑤.
- Remove the water pump case and clutch cover. (Refer to page 3-18)

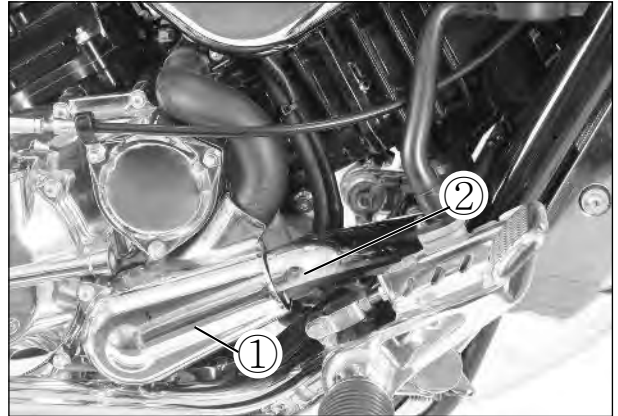

NOTE

Before draining engine oil and engine coolant, inspect engine oil and coolant leakage between the water pump and clutch cover.

If engine oil is leaking, visually inspect the oil seal and O-ring. If engine coolant is leaking, visually inspect the O-ring



- Remove the snap ring and water pump driven gear ⑥.

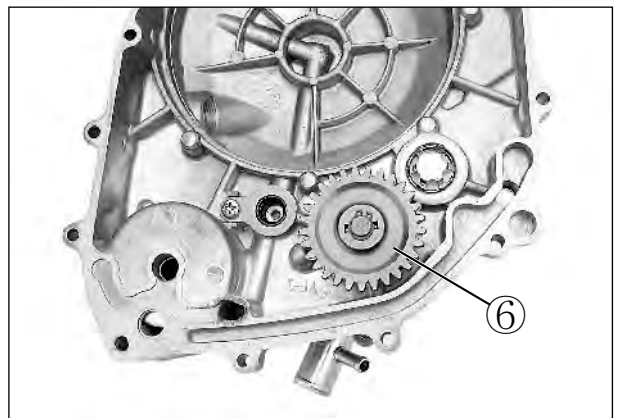

- Remove the pin ⑦ and washer ⑧.

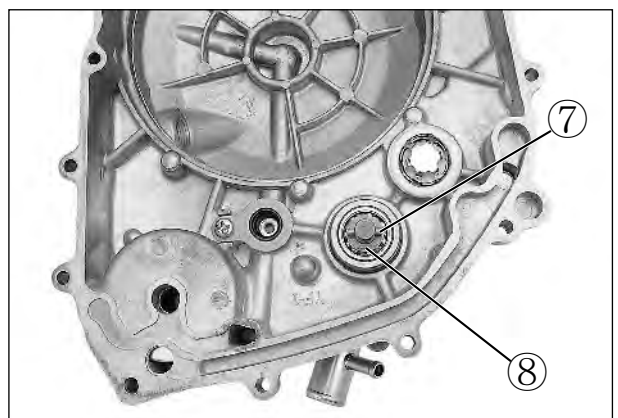

- Remove the water pump ① from the clutch cover.



- Remove the O-rings ②.

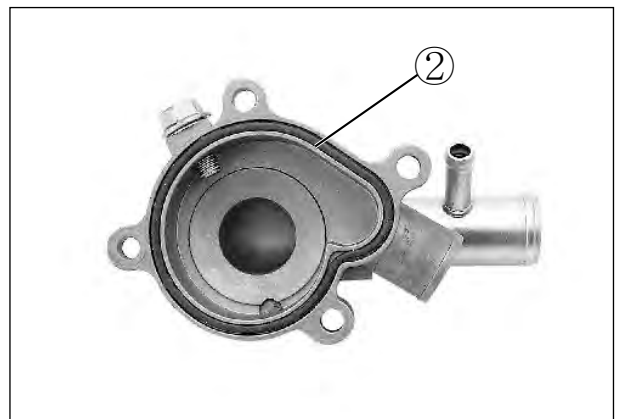

- Remove the E-ring ③ from the impeller shaft.

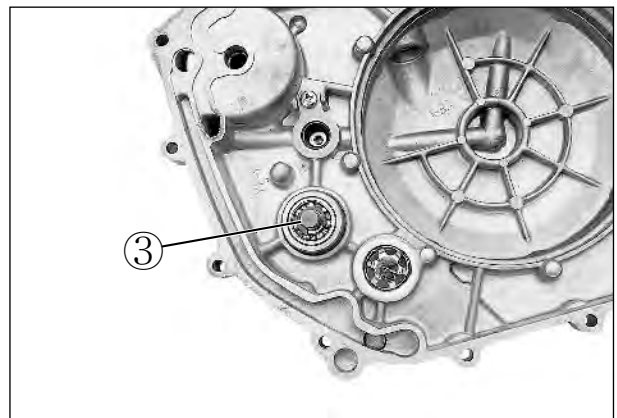

- Remove the impeller ④ from the other side.



- Remove the bearing.

NOTE

If there is no abnormal noise, bearing removal is not necessary.

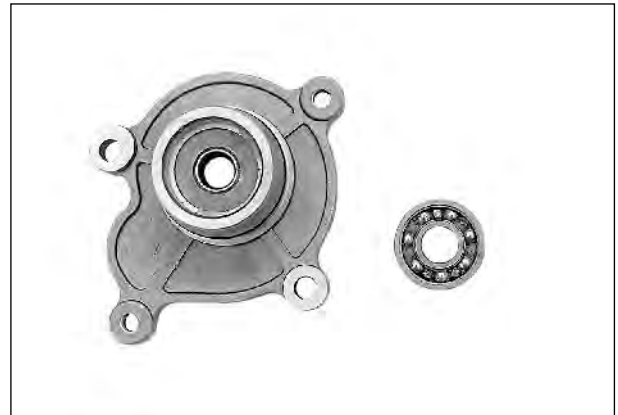

○ **INSPECTION**

■ **BEARING**

Inspect the play of the bearing by hand while it is in the water pump case.
Rotate the inner race by hand to inspect abnormal noise and smooth rotation.
Replace the bearing if there is anything unusual.



■ **BEARING CASE**

Visually inspect the bearing case for damage.
Replace the water pump body if necessary.



○ **REASSEMBLY AND INSTALLATION**

Install the water pump in the reverse order of removal.
Pay attention to the following points :
● Install the bearing.

NOTE

The stamped mark on the bearing faces to the crankcase side.

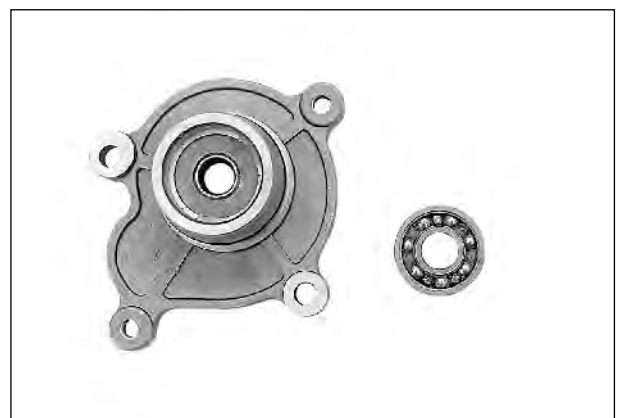

- Apply **SUPER GREASE "A"** to the impeller shaft.

 **SUPER GREASE "A"**

- Install the impeller to the water pump body.

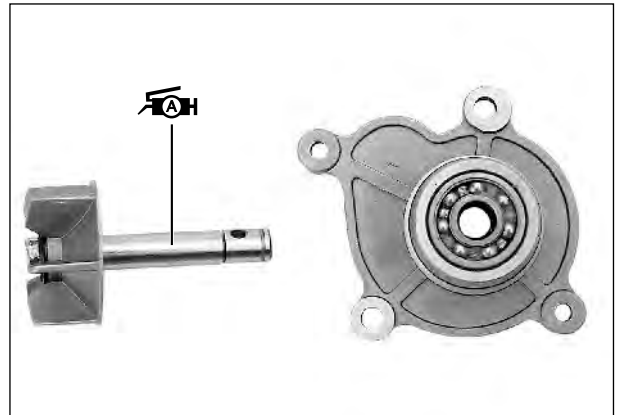

- Fix the impeller shaft with the E-ring ①.
- Fill the bearing with engine oil until engine oil comes out from the hole of the bearing housing.

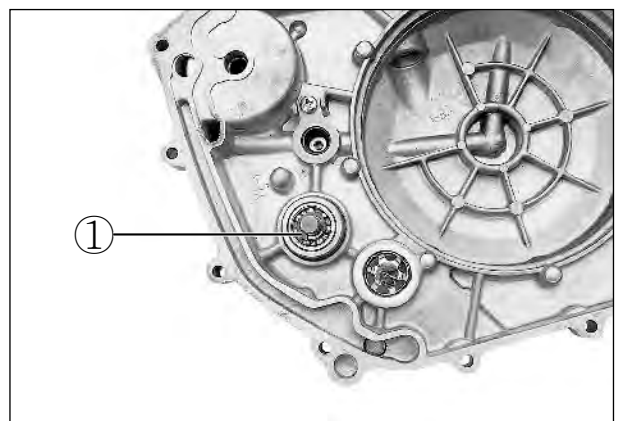

- Apply engine coolant to the O-ring ②.
- Install a new O-ring.

 **CAUTION**

Use a new O-ring to prevent engine coolant leakage.

- Connect the water hoses.
- Install the radiator outlet hose cover.
- Install the water pump cover.
- Pour engine coolant. (Refer to page 2-25)
- Pour engine oil. (Refer to page 2-12)

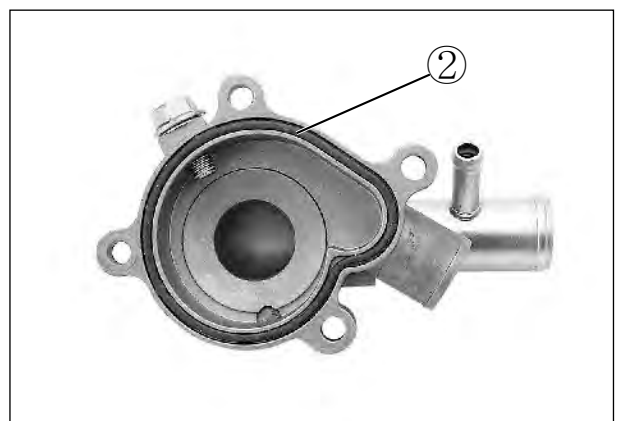

ELECTRICAL SYSTEM

CONTENTS

LOCATION OF ELECTRICAL COMPONENTS	7- 1
IGNITION SYSTEM.....	7- 4
CHARGING SYSTEM	7- 8
STARTER SYSTEM AND SIDE STAND IGNITION INTERLOCK SYSTEM	7-10
SWITCHES	7-14
LAMP	7-15
BATTERY	7-17

LOCATION OF ELECTRICAL COMPONENTS

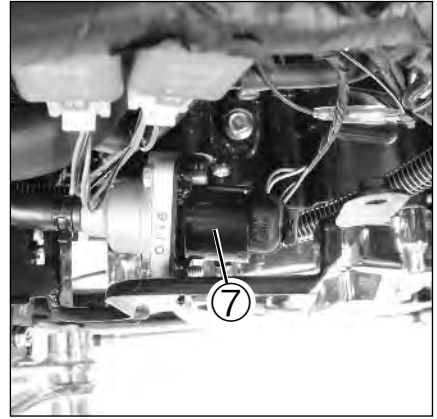
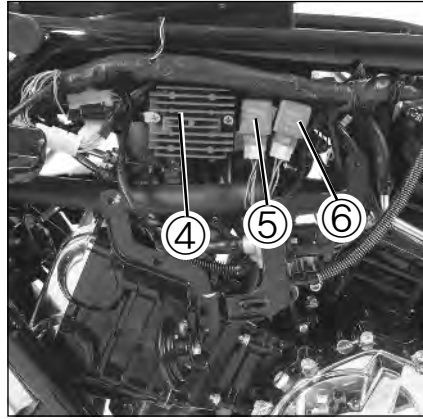
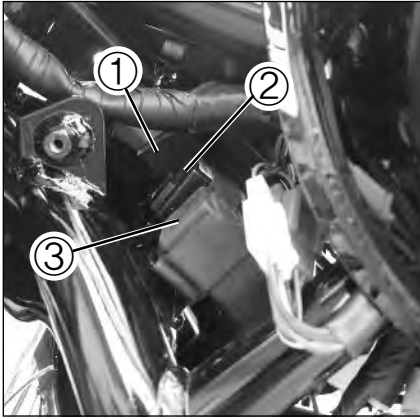

- ① Ignition coil NO.1
- ② Turn signal relay
- ③ Side stand relay

- ④ Regulator / Rectifier
- ⑤ Main relay
- ⑥ Fuel pump relay

- ⑦ ISC solenoid

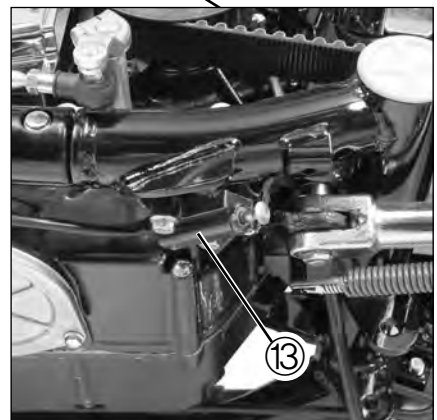
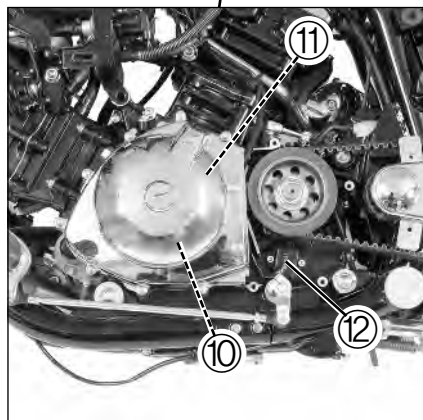
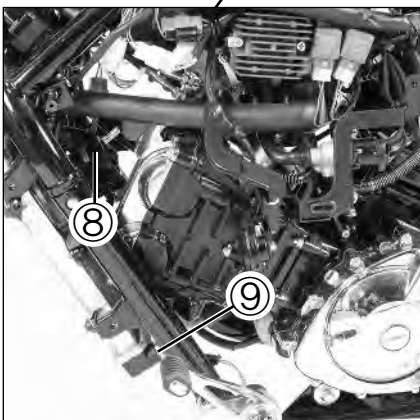
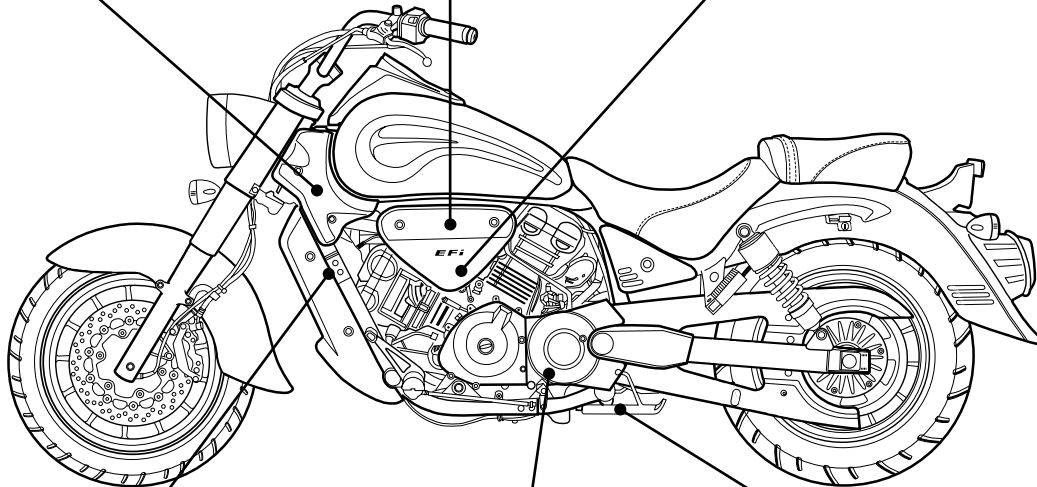

- ⑧ Cooling fan motor
- ⑨ Cooling fan thermo-switch

- ⑩ Magneto
- ⑪ Pick-up coil
- ⑫ GP switch

- ⑬ Side stand switch

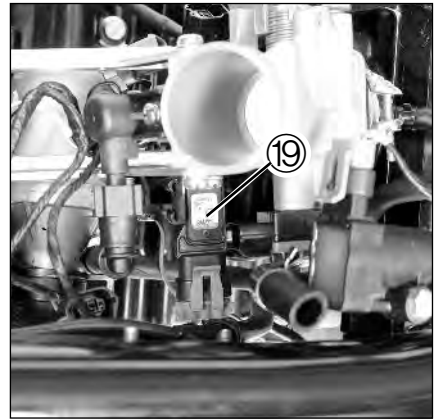
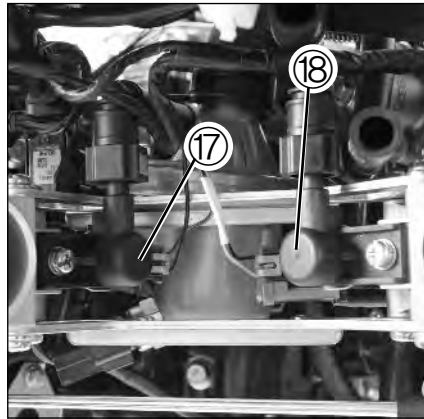
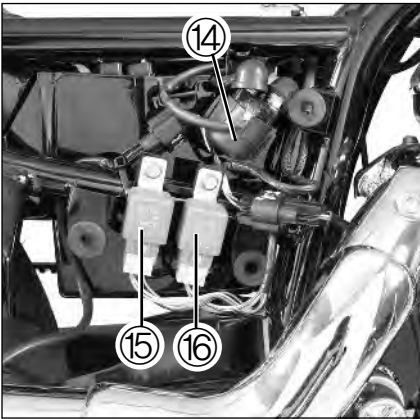

- ⑭ Starter motor relay
- ⑮ Cooling fan motor relay
- ⑯ Head lamp relay

- ⑰ Fuel injector NO.2
- ⑱ Fuel injector NO.1

- ⑲ IAP sensor

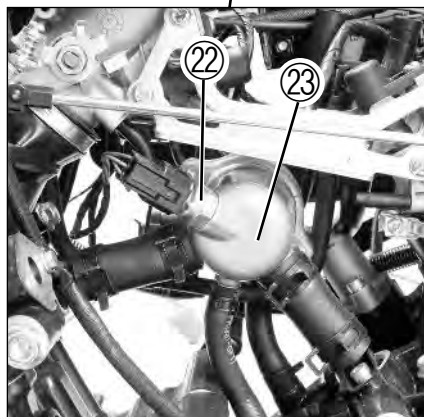
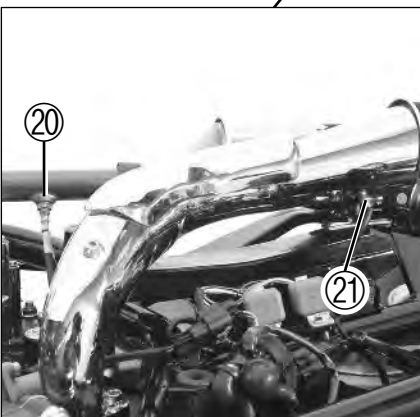
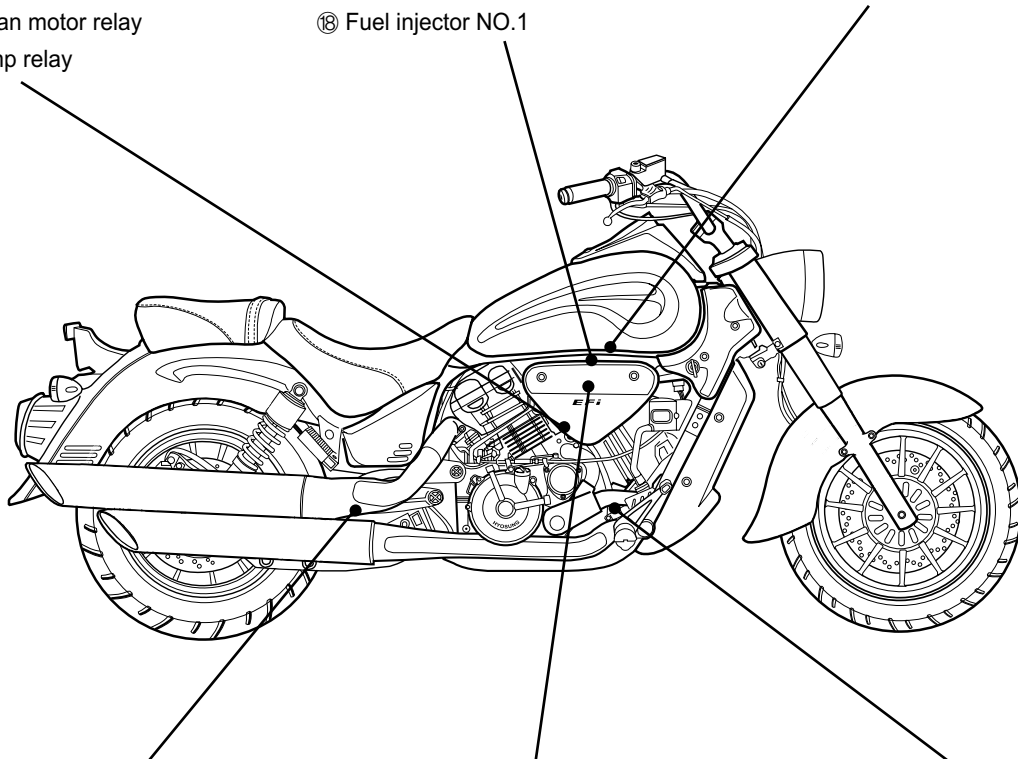

- ⑳ Oxygen sensor NO.1
- ㉑ Oxygen sensor NO.2

- ㉒ WT sensor
- ㉓ Thermostat

- ㉔ Rear brake lamp switch

7-3 ELECTRICAL SYSTEM

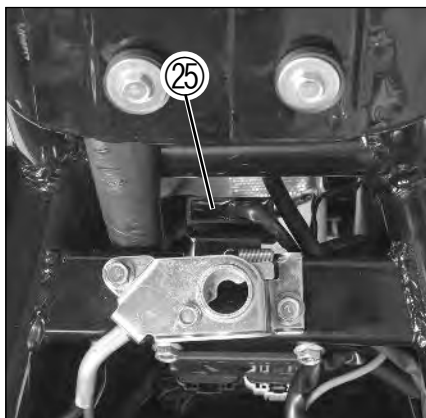

⑫ RO switch

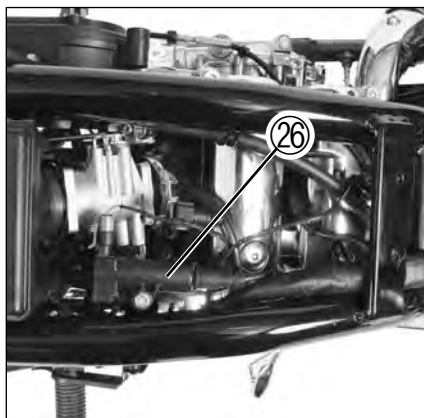

⑬ Ignition coil NO.2

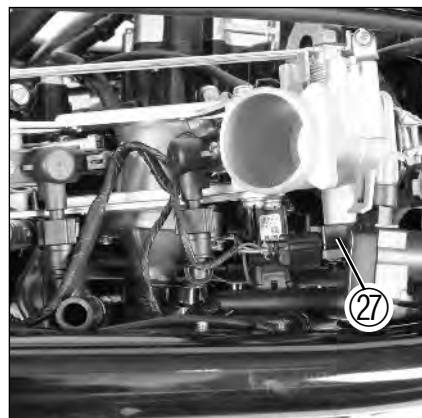

⑭ TP sensor

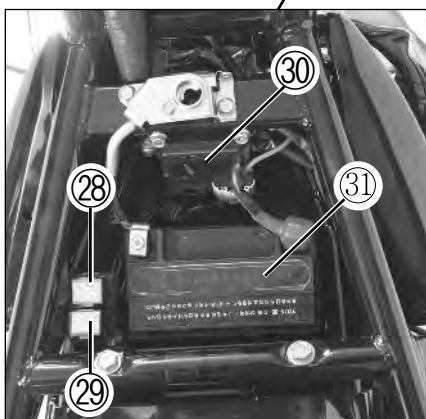
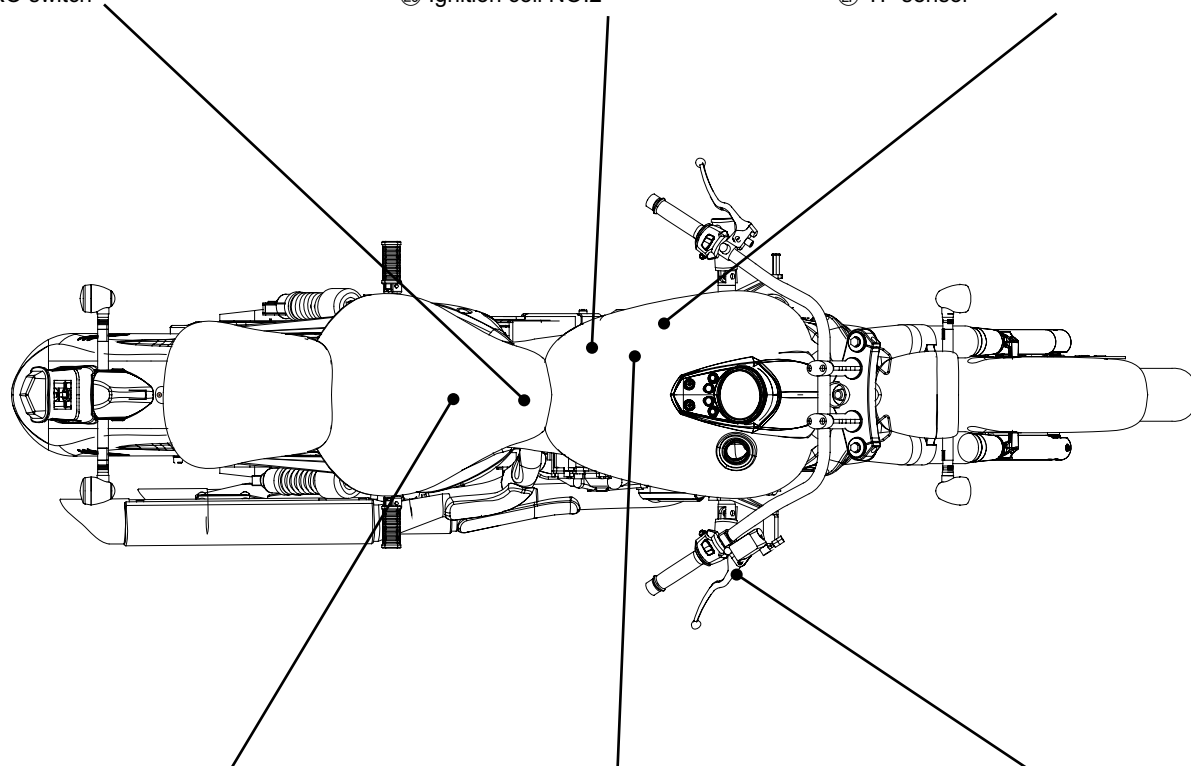

⑮ ECU fuse (15A)

⑯ Main fuse (30A)

⑰ ECU

⑱ Battery

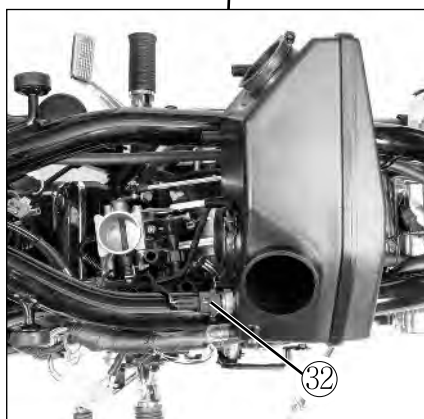

⑲ IAT sensor

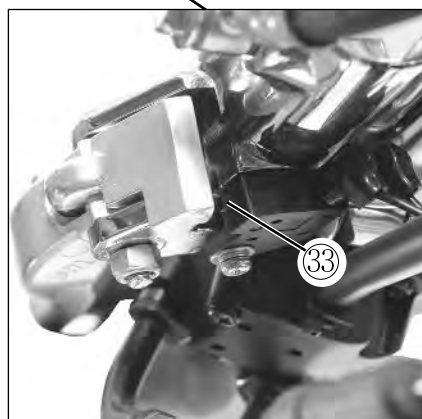

⑳ Front brake lamp switch

IGNITION SYSTEM

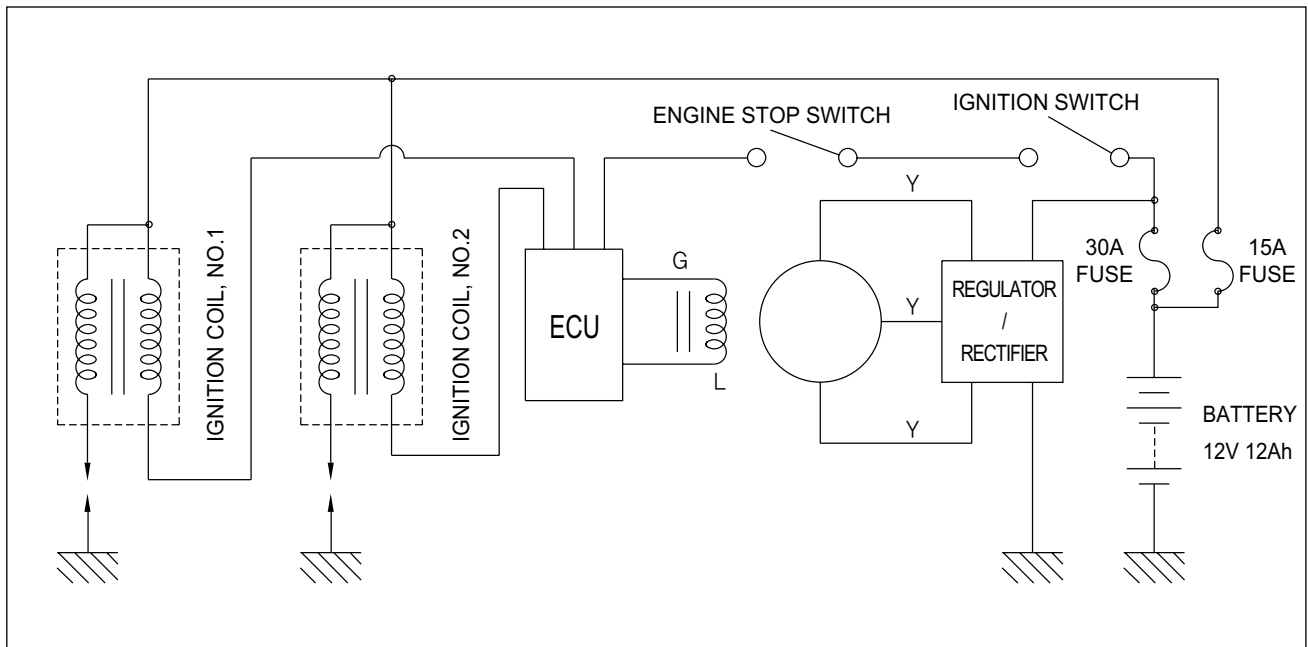

⊙ INSPECTION

▣ MAGNETO

Using the pocket tester, measure the resistance between the lead wires in the following table.

If the resistance is not within the specified value, replace the stator coil, with a new one.

Stator coil resistance	Standard
Pick-up coil	G-L 110 ~ 140 Ω
Charging coil	Y-Y 0.2 ~ 0.4 Ω

 Tester knob indication : Resistance (Ω)

NOTE

When making above test, it is not necessary to remove the magneto.

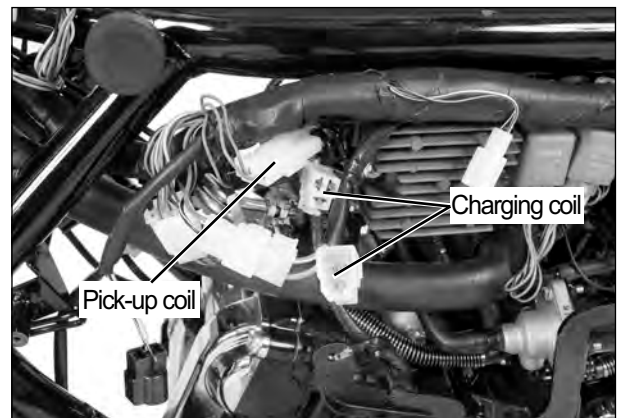

IGNITION COIL PRIMARY PEAK VOLTAGE INSPECTION

- Remove the fuel tank and frame cover.
- Disconnect the two spark plug caps.
- With the spark plug cap connected, place a new spark plug on the engine to ground it.

NOTE

- ❖ Check that all the couplers are connected.
- ❖ Check that the all battery is fully charged.

Measure the No.1 and No.2 ignition coil primary peak voltage using the tester in the following procedure.

- Connect the tester as follows.

NO.1 Ignition coil

- ⇒ ⊕ Probe : BY lead wire terminal
- ⇒ ⊖ Probe : Ground

NO.2 Ignition coil

- ⇒ ⊕ Probe : WL lead wire terminal
- ⇒ ⊖ Probe : Ground

NOTE

Do not disconnect the ignition coil / plug cap lead wire couplers.

TOOL Pocket tester : 09900-25002

- Shift the transmission into the neutral and then turn the ignition switch to the "ON" position.
- Squeeze the clutch lever.
- Press the starter switch and allow the engine to crank for a few seconds, and then measure the ignition coil primary peak voltage.
- Repeat the above procedure a few times and measure the highest ignition coil primary peak voltage.

Ignition coil primary peak voltage 400 V and more

Tester knob indication : Voltage (V)

WARNING

While testing, do not touch the tester probes and spark plugs to prevent receiving an electric shock.

If the peak voltage is lower than the specified values, inspect the ignition coil. (Refer to the next page.)

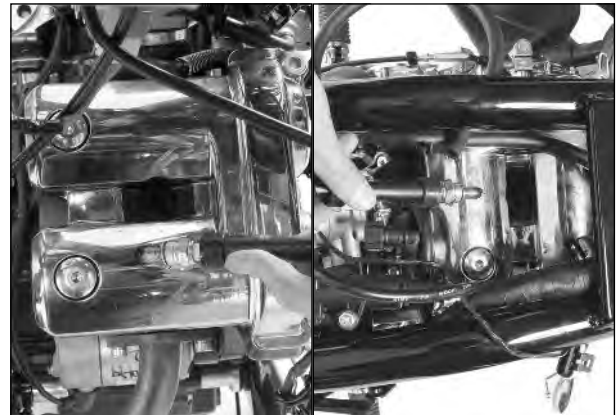

Front cylinder

Rear cylinder

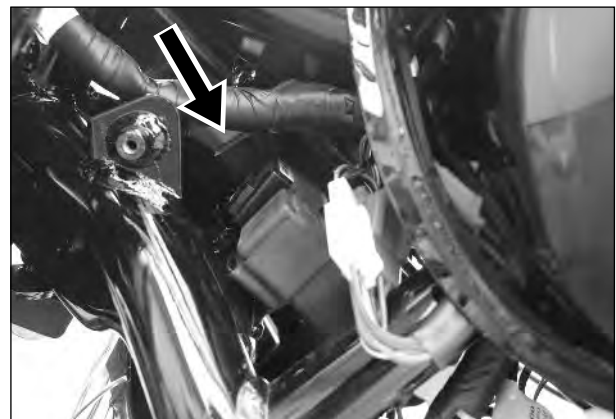
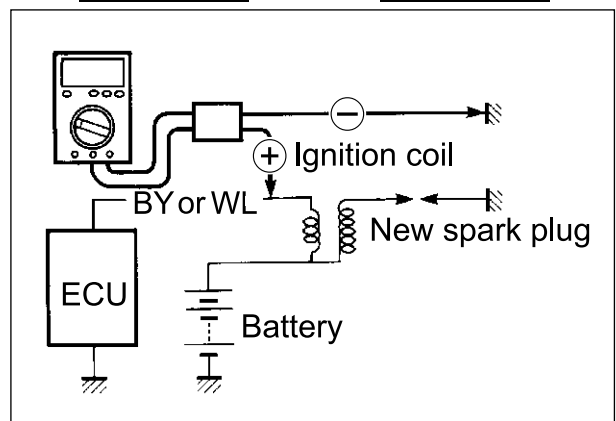

Ignition coil NO.1

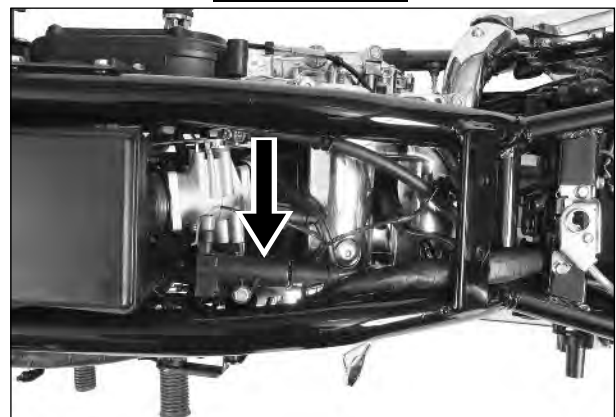

Ignition coil NO.2

■ IGNITION COIL RESISTANCE INSPECTION

- Remove the fuel tank. (Refer to page 5-2)
- Disconnect the ignition coil read wire.

Measure the ignition coil resistance in both the primary and secondary windings. If the resistance is not within the standard range, replace the ignition coil with a new one.

IGNITION COIL / PLUG CAP RESISTANCE

Primary	0.52 ~ 0.64 Ω (\oplus Terminal - \ominus Terminal)
Secondary	6.4 ~ 7.8 K Ω (Plug cap - \oplus Terminal)

 **TOOL** Pocket tester : 09900-25002

 **Tester knob indication : Resistance (Ω)**

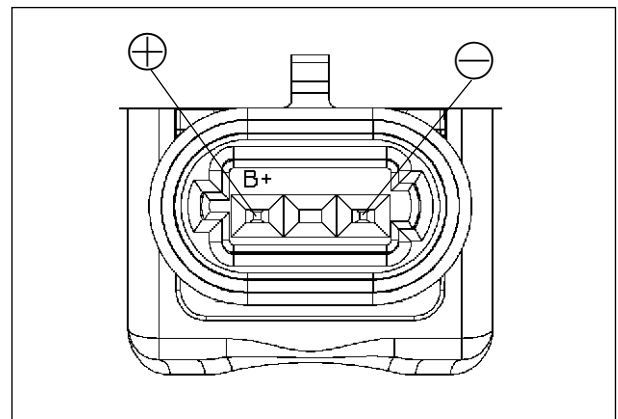
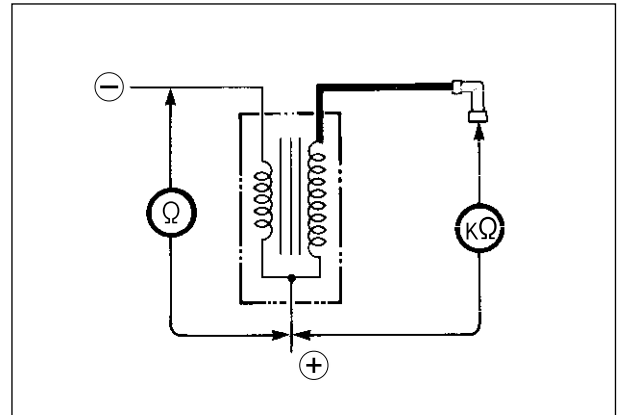

■ SPARK PLUG

◆ CARBON DEPOSITS

Check to see if there are carbon deposits on the spark plug.

If carbon is deposited, remove it with a spark plug cleaner machine or carefully use a tool with a pointed end.

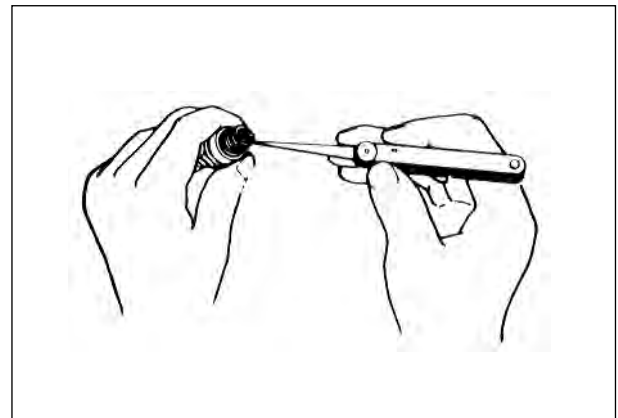

◆ SPARK PLUG GAP

Measure the spark plug gap with a thickness gauge.

If the spark plug gap is out of specification, adjust the gap.

Spark plug gap

0.7 ~ 0.8 mm
(0.028 ~ 0.032 in)

 **TOOL** Thickness gauge : 09900-20806

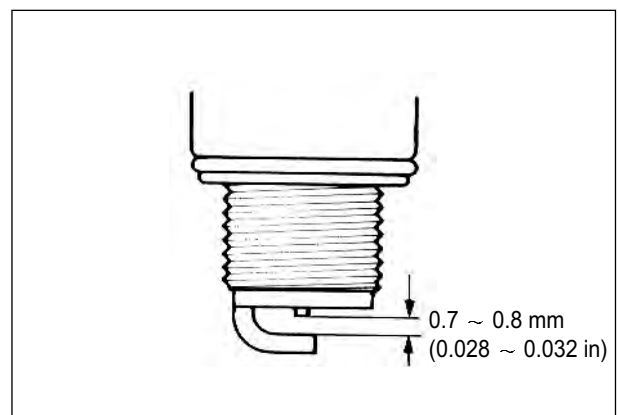

7-7 ELECTRICAL SYSTEM

◆ ELECTRODE'S CONDITION

Check to see the worn or burnt condition of the electrodes.

If it is extremely worn or burnt, replace the spark plug. Replace the spark plug if it has a broken insulator, damaged thread, etc.

 CAUTION
--

<p>Use recommended spark plugs only. A spark plug of the wrong rating may shorten engine life and cause loss of performance.</p>

◆ SPARK PLUG INSTALLATION

 CAUTION
--

<p>Before tightening the spark plug to the specified torque, carefully turn the spark plug by finger into the threads of the cylinder head to prevent damage the aluminum threads.</p>

- First, finger tighten the spark plugs, and then tighten them to the specified torque.

 **Spark plug : 11 N · m (1.1 kgf · m)**

CHARGING SYSTEM

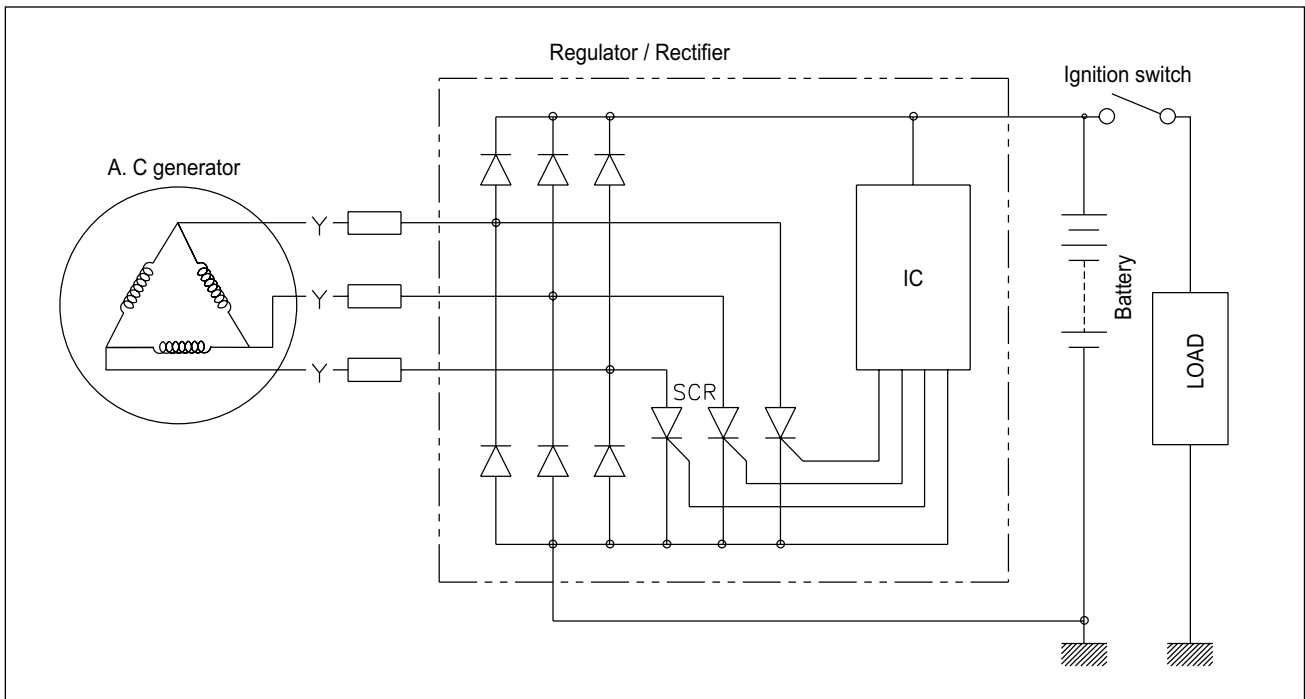

⊙ INSPECTION

▣ CHARGING OUTPUT CHECK

Start the engine and keep it running at 5,000 rpm.

Using the pocket tester, measure the DC voltage between the battery terminal ⊕ and ⊖.

If the voltage is not within the specified value, check the magneto no-load performance and regulator / rectifier.

⚠ CAUTION

When making this test, be sure that the battery is full-charged condition.



Standard charge 13.5 ~ 15.0 V (at 5,000 rpm)

TOOL Pocket tester : 09900-25002

Tester knob indication : Voltage (---)

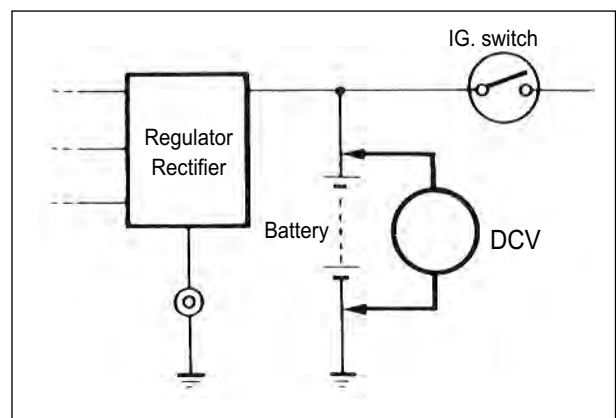

■ MAGNETO NO-LOAD PERFORMANCE

Disconnect the three lead wires from the magneto terminal.

Start the engine and keep it running at 5,000 rpm. Using the pocket tester, measure the AC voltage between the three lead wires.

If the voltage is under the specified value, replace the magneto with a new one.

Standard NO-load performance of magneto	Over 70 V (at 5,000 rpm)
--	--------------------------

 **TOOL Pocket tester : 09900-25002**

 **Tester knob indication : Voltage (---)**

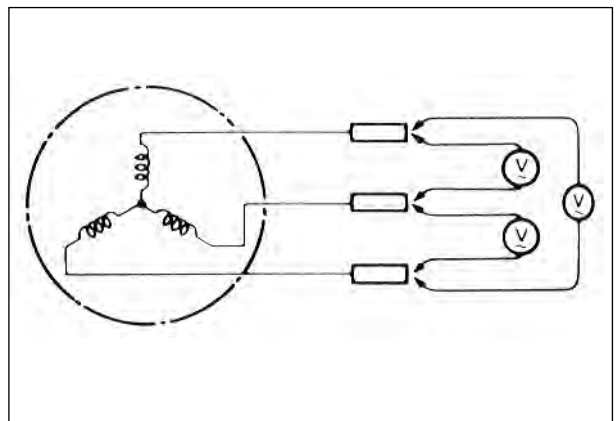
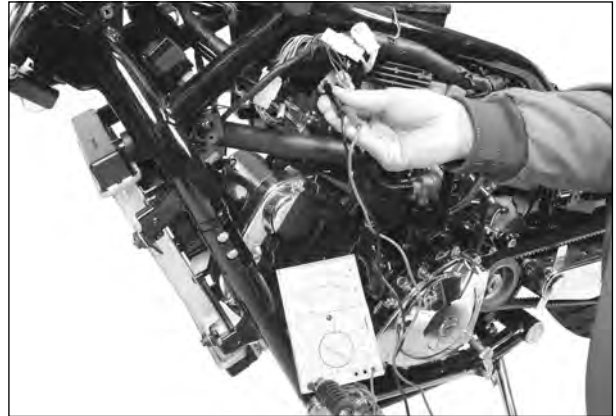

■ REGULATOR / RECTIFIER

Disconnect the regulator / rectifier couplers.

Measure the voltage between the terminals using the pocket tester as indicated in the table below.

If the voltage is not within the specified value, replace the regulator / rectifier with a new one.

Unit : V

Tester probe	⊕ Tester probe				
	①	②	③	④	⑤
①		0	0	0	0.4~0.7
②	0		0	0	0.4~0.7
③	0	0		0	0.4~0.7
④	0.4~0.7	0.4~0.7	0.4~0.7		0.5~1.2
⑤	0	0	0	0	

 **TOOL Pocket tester : 09900-25002**

 **Tester knob indication : Diode test (↔)**

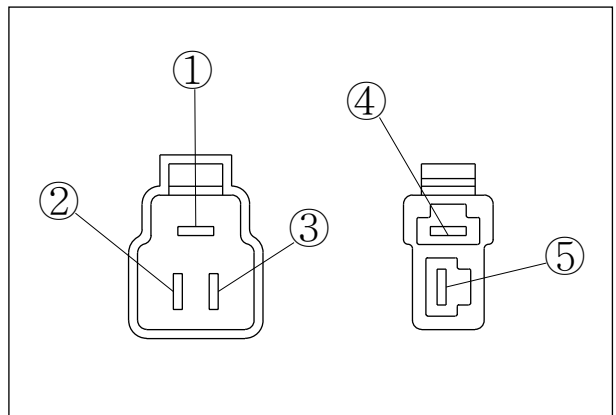
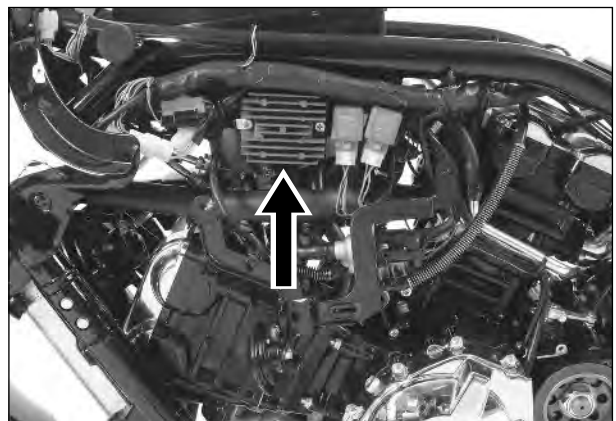

STARTER SYSTEM AND SIDE STAND IGNITION INTER-LOCK SYSTEM

STARTER SYSTEM DESCRIPTION

The starter system consists of the following components : the starter motor, starter relay, clutch lever switch, side stand switch, neutral switch, starter switch, engine stop switch, ignition switch and battery.

Pressing the starter switch (on the right handlebar switch) energizes the starter relay, causing the contact points to close, thus completing the circuit from the starter motor to the battery.

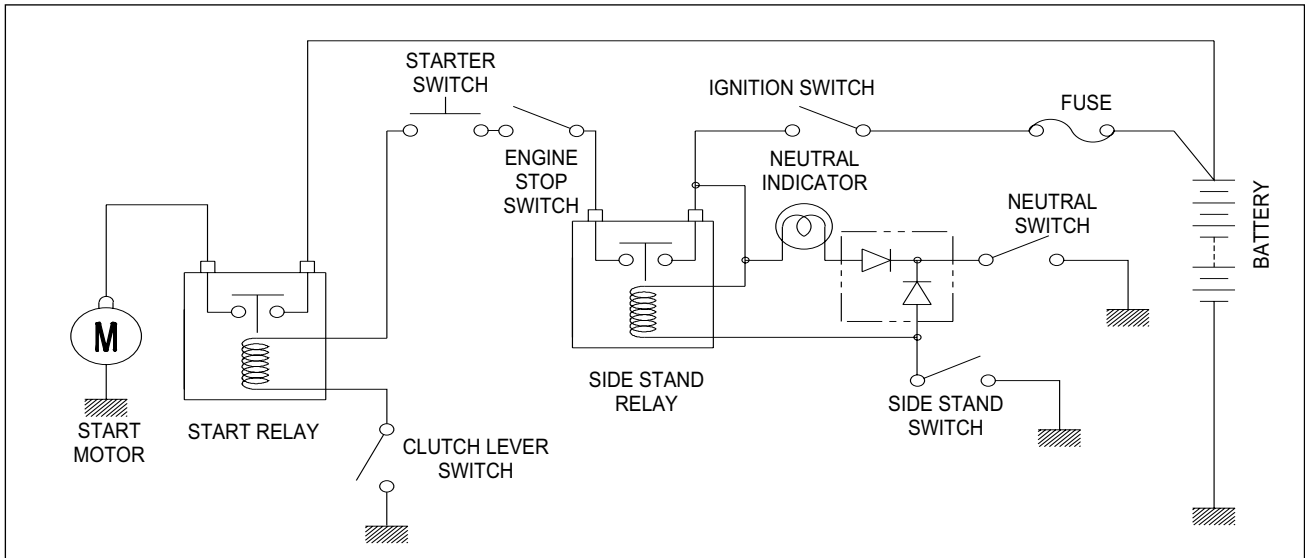

SIDE STAND / IGNITION INTERLOCK SYSTEM DESCRIPTION

This side stand / ignition interlock system prevents the motorcycle from being started with side stand down. The system is operated by an electric circuit provided between the battery and ignition coil.

The circuit consists of the neutral indicator light and switches.

The ignition coils will send voltage to the spark plugs depending on what gear the transmission is in and whether the side stand is either up or down.

The gear position and side stand switches work together in this system.

The ignition coil work only in two situations as follows.

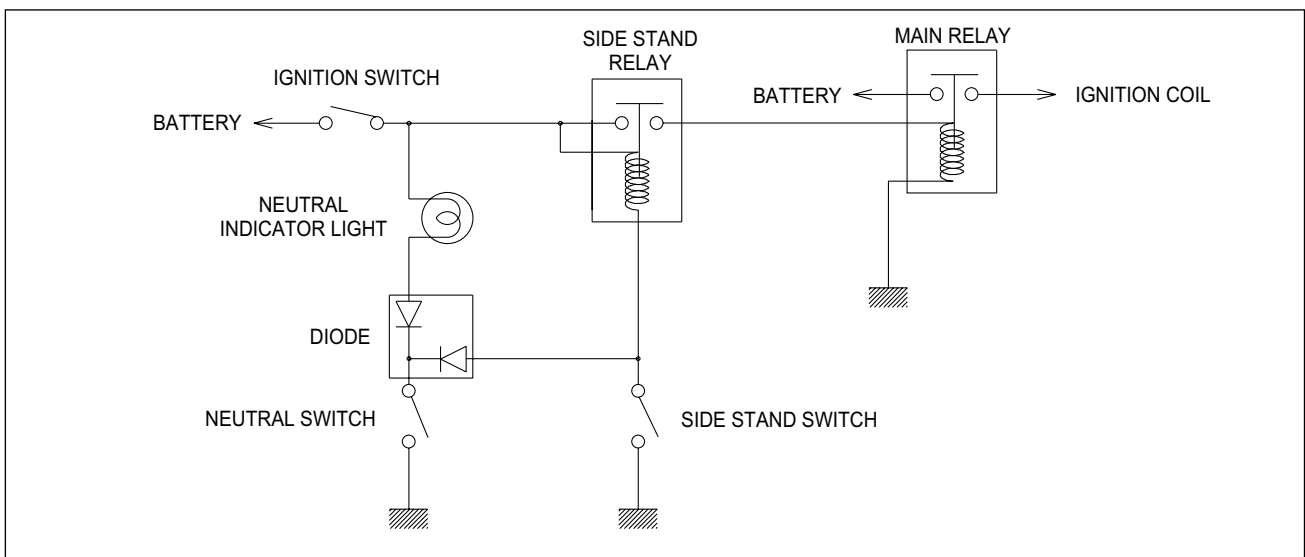

7-11 ELECTRICAL SYSTEM

- TRANSMISSION : Neutral - "ON "**
 Side stand - Down
 Clutch lever - Squeeze

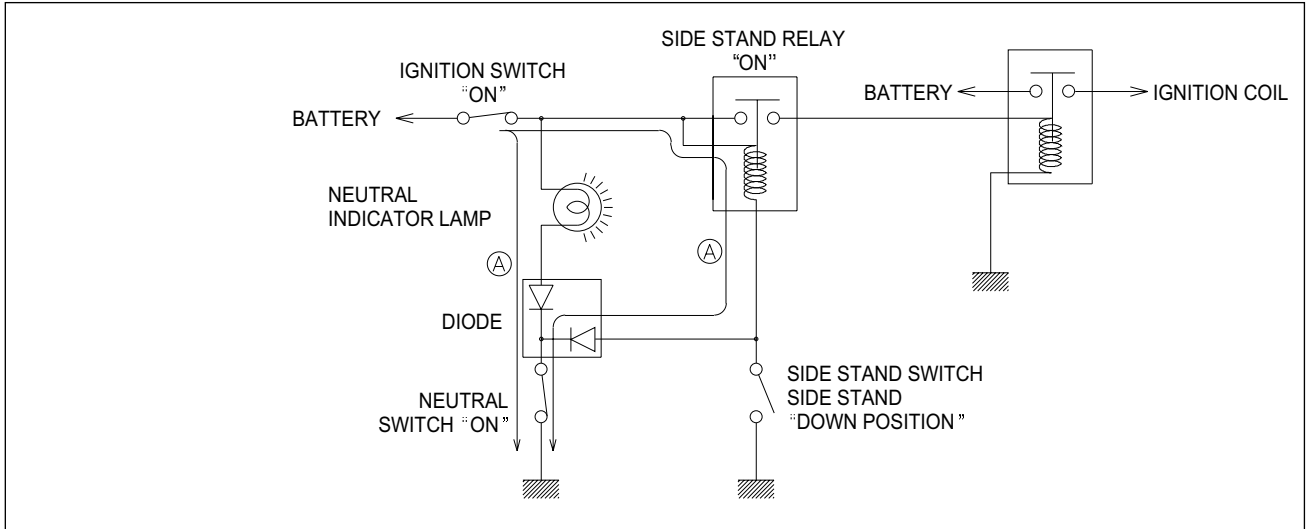

- TRANSMISSION : Neutral - "OFF "**
 Side stand - Up
 Clutch lever - Squeeze

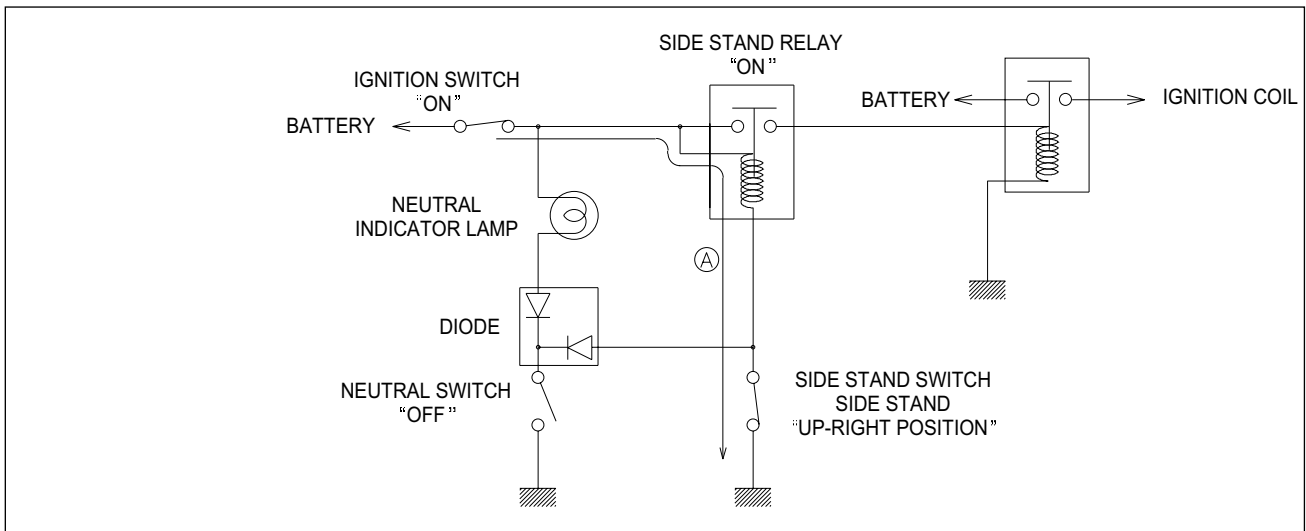

『ST7』 is equipped with the side stand ignition interlock system.

If the transmission is in neutral or side stand up, you can only start the engine with pulling the clutch lever.

NO	Neutral switch	Clutch lever	Side stand	Engine Start
1	●	●	△	Possible
2	△	●	●	Possible
3	●	△	△	Impossible
4	△	●	△	Impossible
5	△	△	●	Impossible

NOTE	
●	On or Up
△	Off or Down

○ STARTER MOTOR REMOVAL AND DISASSEMBLY

- Disconnect the starter motor lead wire.
- After loosening the bolts ①, remove the starter motor.
- Disassemble the starter motor.



○ STARTER MOTOR INSPECTION

■ CARBON BRUSH

Inspect abnormal wear, crack or smoothness of the brushes in the brush holder.

If the brush has failed, replace the brush sub Assy.

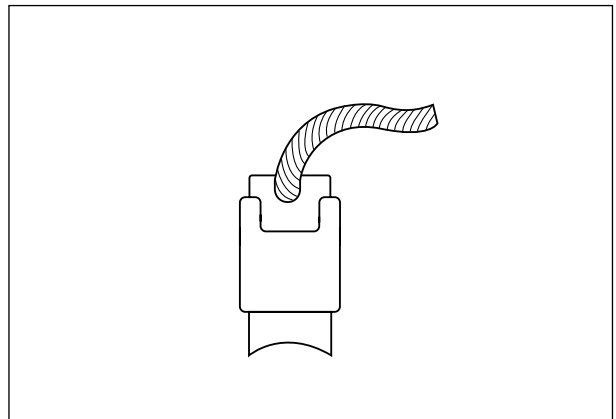

■ COMMUTATOR

Inspect discoloration, abnormal wear or undercut ① of the commutator.

If the commutator is abnormally worn, replace the armature.

When surface is discolored, polish it with #400 sand paper and clean it with dry cloth.

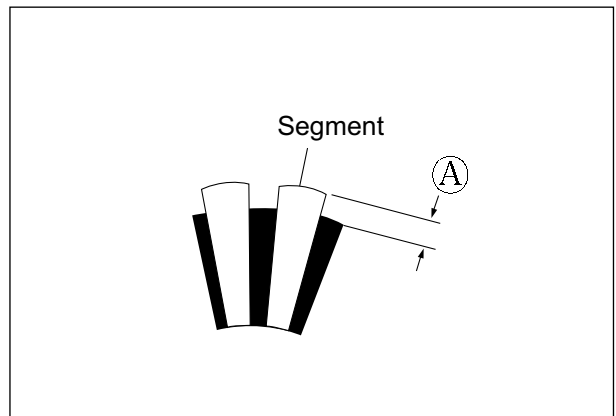

■ ARMATURE COIL INSPECTION

Check continuity between each segment.

Check continuity between each segment and the armature shaft.

If there is no continuity between the segments or there is continuity between the segment and shaft, replace the starter motor with a new one.

 **TOOL** Pocket tester : 09900-25002

 **Tester knob indication**

: Continuity test (•)))

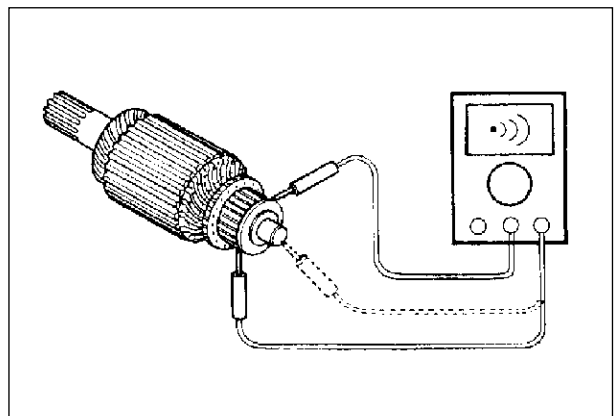

● STARTER MOTOR REASSEMBLY

Reassemble the starter motor. Pay attention to the following points :

- Reassembly the starter motor as shown in the illustration.

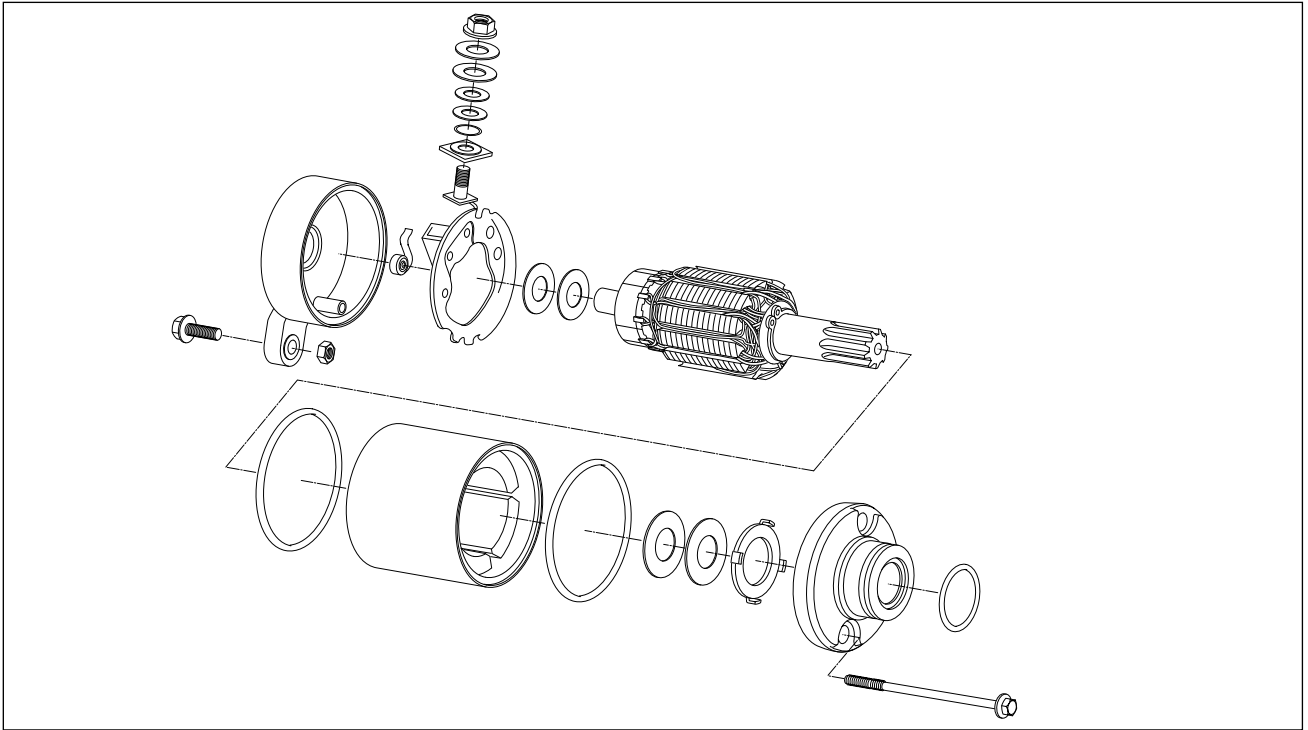

- Align the match mark ① on the housing with the line ② on the housing end.

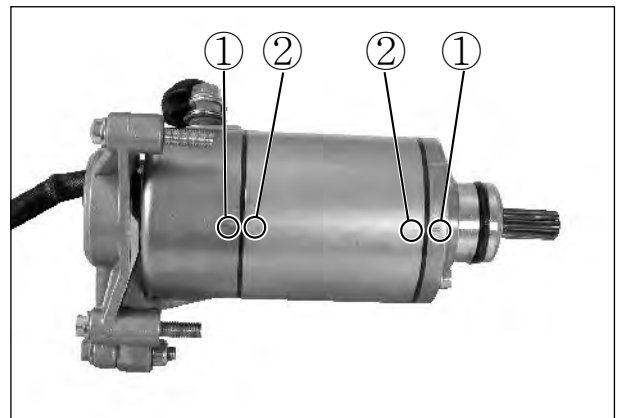

- Apply **SUPER GREASE "A"** to the O-ring ③ and remount the starter motor.

 **SUPER GREASE "A"**

- Install the starter motor.

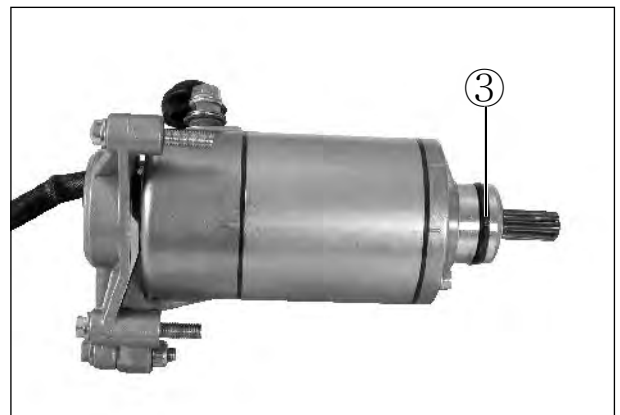

SWITCHES

Measure each switch for continuity using a tester.

If any abnormality is found, replace the respective switch assemblies with new ones.

 **Pocket tester : 09900-25002**

IGNITION SWITCH				
	R	O	BW	BR
ON				
OFF				

ENGINE STOP SWITCH		
	O	OB

HAZARD SWITCH		
	Sb	Gr

STARTER SWITCH		
	OB	YR
PUSH		
OFF		

DIMMER SWITCH			
	YW	Y	W

CLUTCH LEVER SWITCH		
	Br	GR
ON		
OFF		

TURN SIGNAL SWITCH			
	Lg	Sb	B

HORN SWITCH		
	BBr	BW
ON		
OFF		

PASS SWITCH		
	O	Y
ON		
OFF		

FRONT / REAR BRAKE LAMP SWITCH		
	O	WB
ON		
OFF		

LAMP

⚠ CAUTION

If you touch the bulb with your bare hands, clean the bulb with a cloth moistened with alcohol or soapy water to prevent premature bulb failure.

● HEAD LAMP

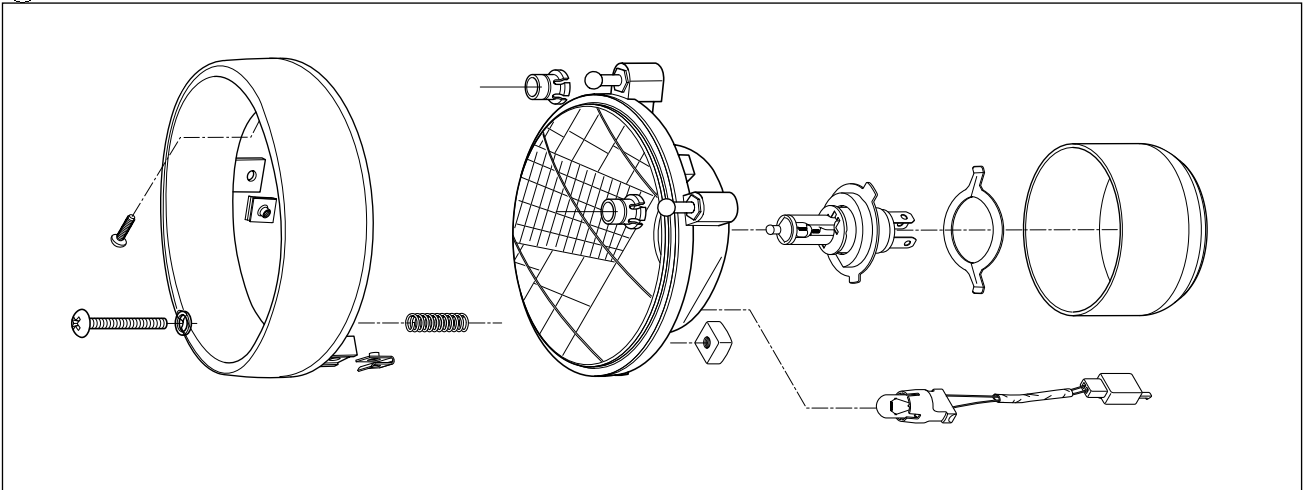

● TURN SIGNAL LAMP

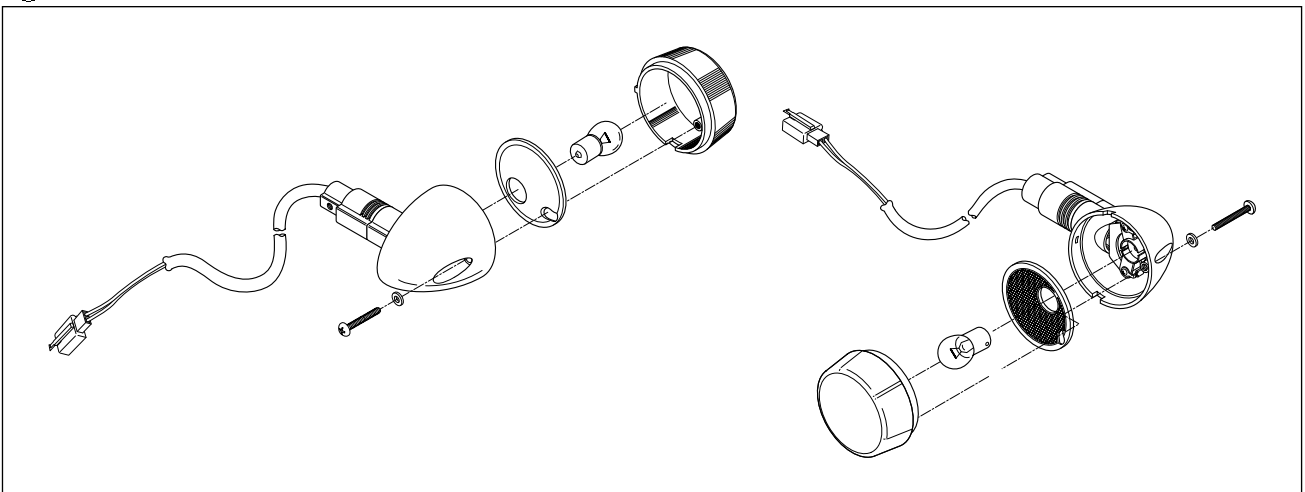

● BRAKE / TAIL LAMP

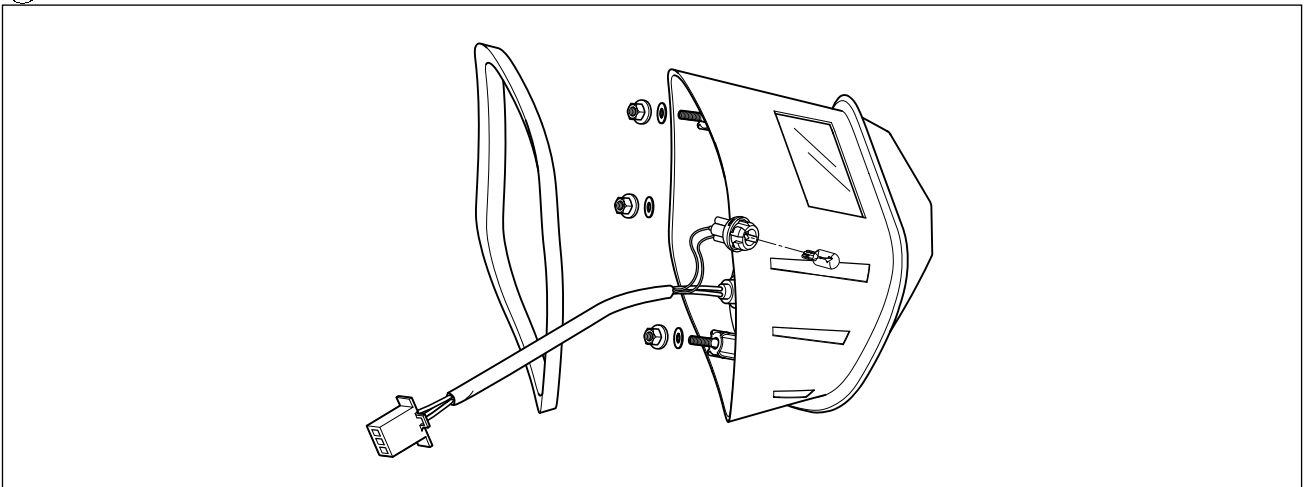

⦿ COMBINATION METER

Remove the combination meter.
Disassemble the combination meter as shown in the illustration.

▣ INSPECTION

Using the pocket tester, check the continuity between lead wires (Blue color coupler and 3 pin coupler) in the following illustration.
If the continuity measured incorrect, replace the respective part.

 **Pocket tester : 09900-25002**

 **Tester knob indication : Continuity test (•••••)**

 CAUTION
<p>When making this test, it is not necessary to remove the combination meter.</p>

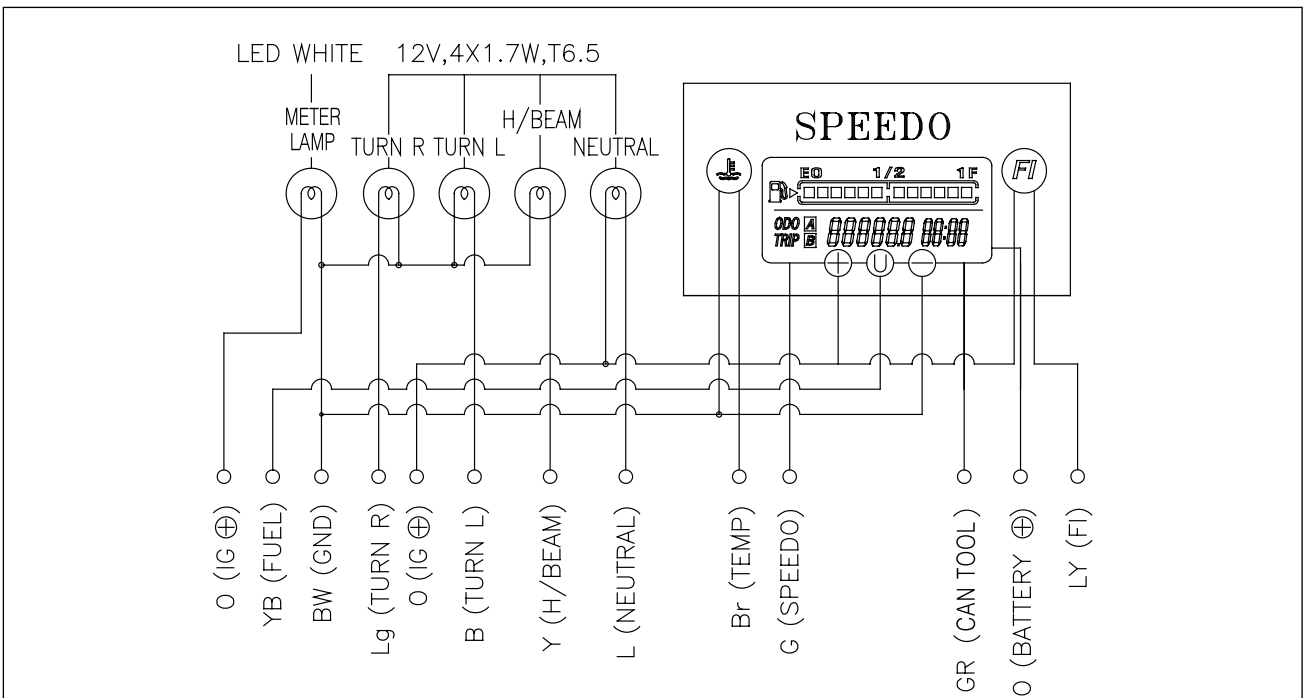
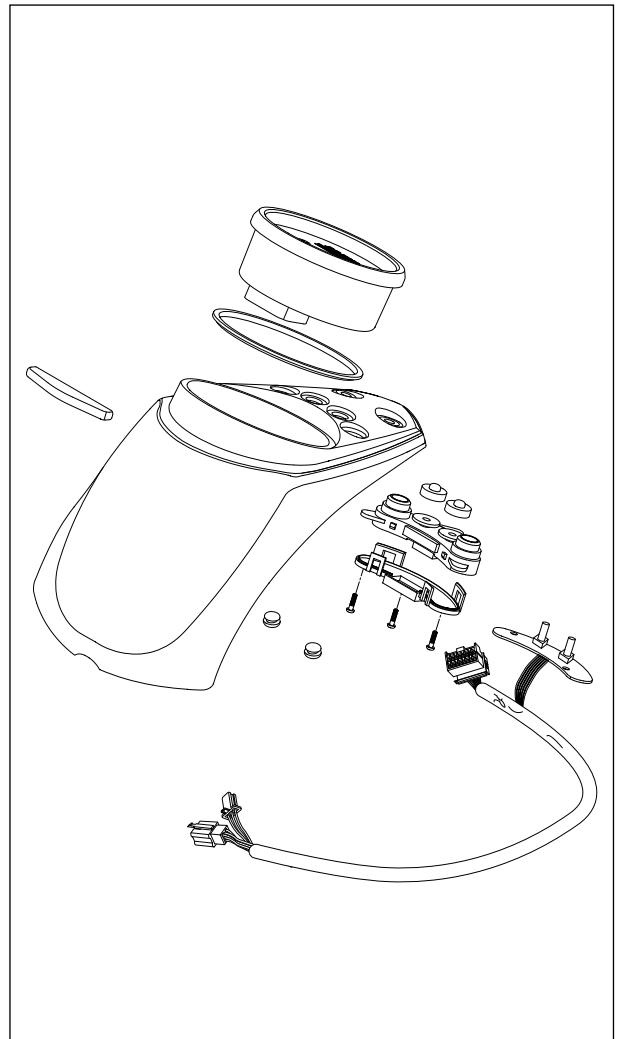
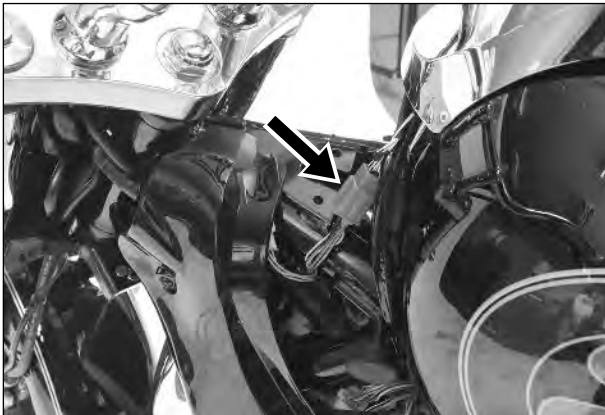

BATTERY

⦿ CAUTION OF BATTERY TREATMENT

The battery needs attention generally as it occur flammability gas.

If you don't follow the instruction in the below, there may be a explosion and severe accident.

Therefore, please pay attention to the following points.

- Positively prohibit battery from contacting to short, spark or firearms.
- The recharge of battery should be done in the wide place where the wind is well ventilated.
Don't recharge it at the sight of wind-proof.

⦿ CAUTION OF BATTERY ELECTROLYTE TREATMENT

- Pay attention to the battery electrolyte not to stains the chassis or the humanbody.
- If stains the chassis or the humanbody, at once wash a vast quantity of water.
When they were stained, clothes will come into being a hole or painting will take off.
Consult a doctor.
- When the battery electrolyte was dropped to the surface of land, wash it with a vast quantity of water.
Neutralize by hydroxide, bicarbonate of soda and so on.

⦿ CAUTION OF MAINTENANCE FREE BATTERY TREATMENT

- Do not remove the aluminum tape to seal the battery electrolyte filler hole until use as battery of complete seal type.
- Do not use it except the battery electrolyte.
- Pouring into the battery electrolyte, necessarily use the electrolyte of the specified capacity.
- Do not open the sealing cap after recharging the battery eletrolyte.

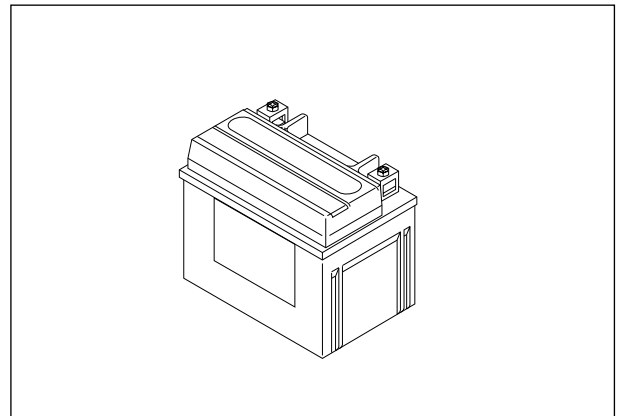

■ FILLING ELECTROLYTE

- ① Put the battery on even land and remove the aluminum tape sealing.
- ② Remove the cap at the electrolyte container.



CAUTION

Do not remove the seal of the electrolyte container, not prick with sharp thing.

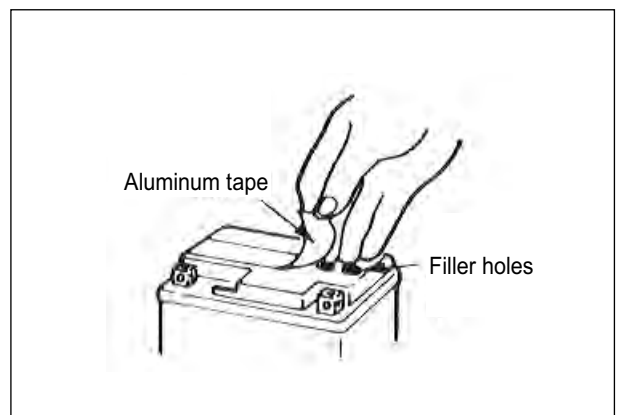

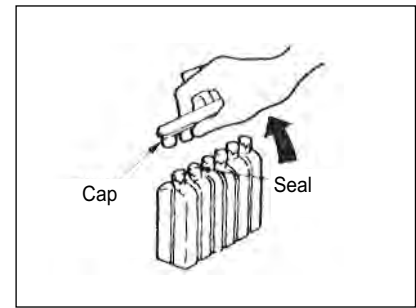
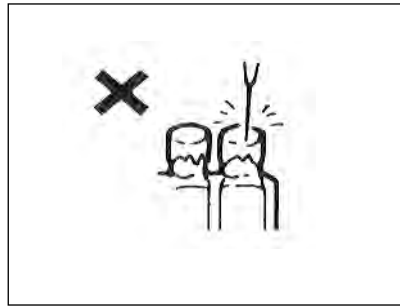
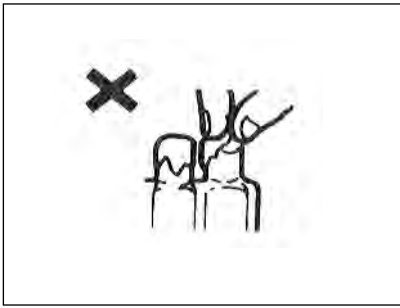

③ Pouring of battery electrolyte

When insert the nozzles of the electrolyte container into the battery's electrolyte filler holes, holding the container firmly so that it does not fall.

Take precaution not to allow any fluid to spill.

CAUTION

The pouring of electrolyte may not be done if the electrolyte container is pushed slopely.

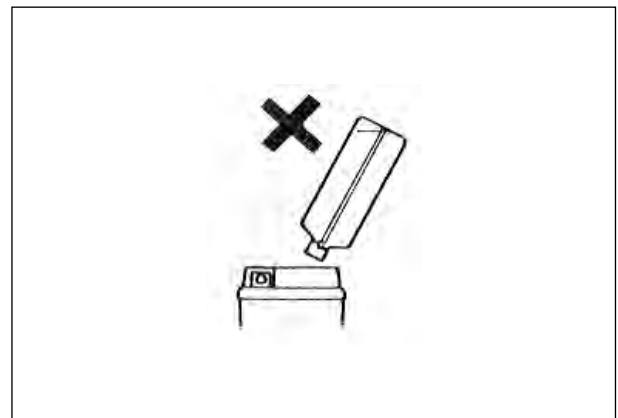
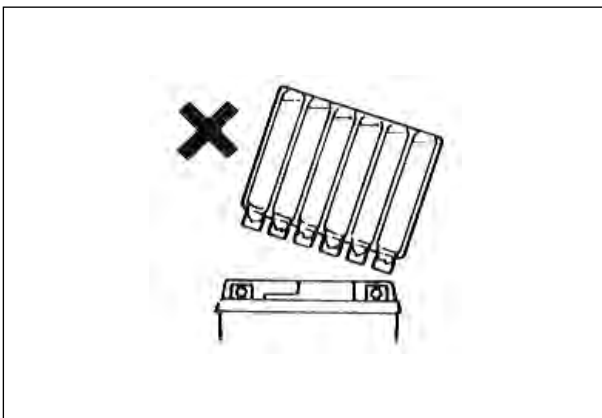
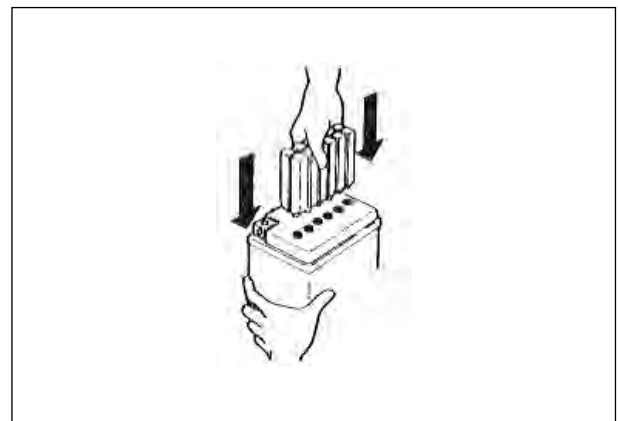

④ Confirmation of pour

Make sure that air bubbles are coming up each electrolyte container, and keep this position for more than about 20 minutes.

CAUTION

If no air bubbles are coming from a filler port, tap the bottom two or three times.

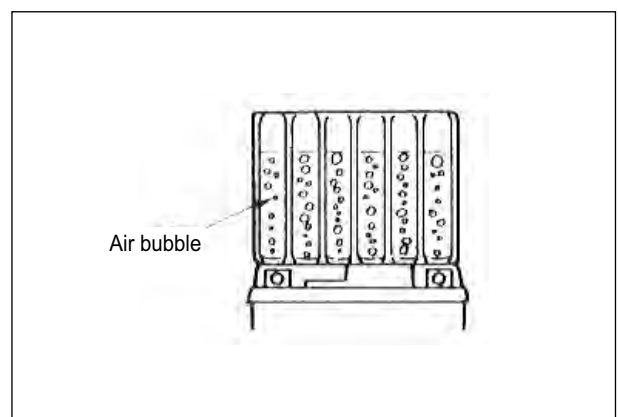

⑤ Separation of electrolyte container

After confirming that you entered the electrolyte into battery completely, remove the electrolyte containers from the battery.

⚠ CAUTION

Draw the empty receptacle out slowly because there may be a chance remaining electrolyte vaporize.

⑥ Insert the caps

Insert the cap into the filler holes, pressing it firmly so that the top of the caps do not protrude above the upper surface of the battery's top cover.

⊙ SERVICING

Visually inspect the surface of the battery container. If any signs of cracking or electrolyte leakage from the sides of the battery have occurred, replace the battery with a new one. If the battery terminals are found to be coated with rust or an acidic white powdery substance, then this can be cleaned away with sandpaper.

⊙ RECHARGING OPERATION

- Using the pocket tester, check the battery voltage. If the voltage reading is less than the 12.0 V (DC), recharge the battery with a battery charger.

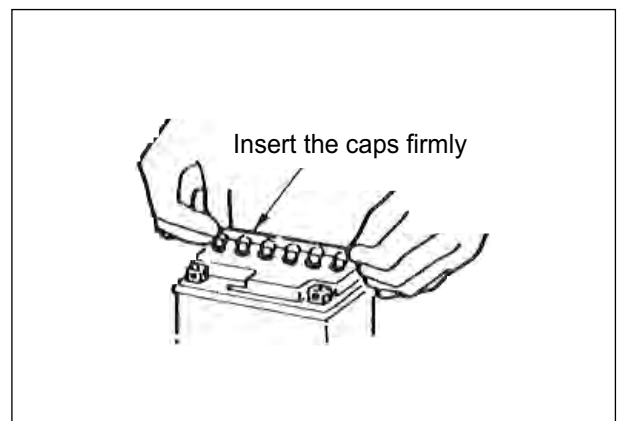
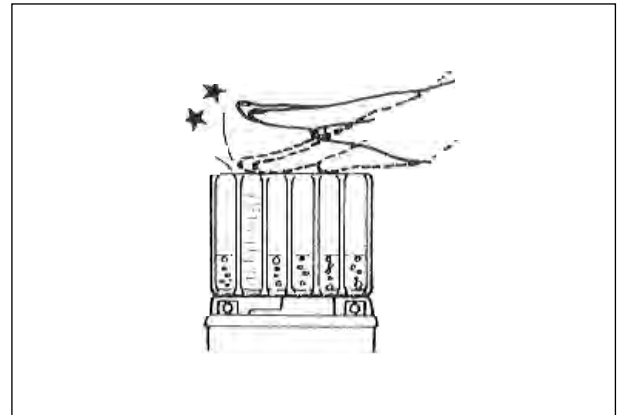

How to charge	
Standard	1.2 A × 5~10 hours
Fast	6 A × 30 minutes

⚠ CAUTION

When recharging the battery, remove the battery from the vehicle.

NOTE

Do not remove the caps on the battery top while recharging.

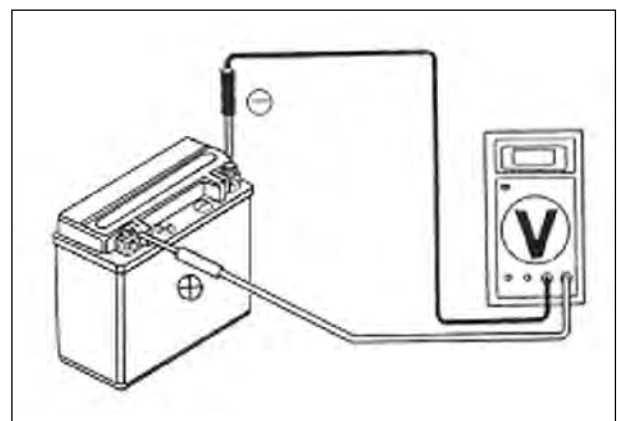

⚠ CAUTION

Be careful not to permit the charging current to exceed 4A at any time.

- After recharging, wait for more than 30 minutes and check the battery voltage with a pocket tester.
- If the battery voltage is less than the 12.5V, recharge the battery again.
- If battery voltage is still less than 12.5V, after recharging, replace the battery with a new one.
- When the vehicle is not used for a long period, check the battery every 1 month to prevent the battery discharge.

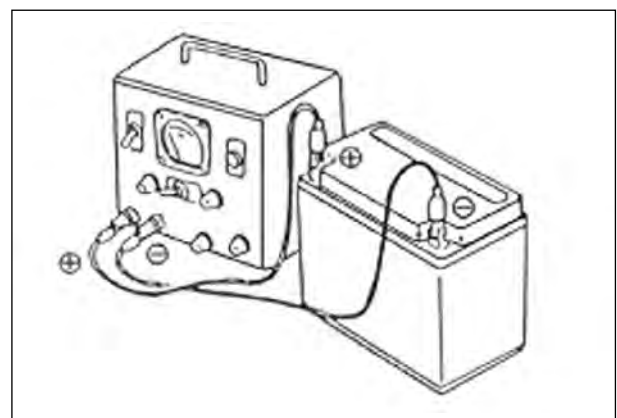

CHASSIS

CONTENTS

EXTERIOR PARTS	8- 1
FRAME COVER	8- 2
SEAT TAIL COVER & SEAT TAIL COVER BRACE	8- 5
FRONT WHEEL	8- 7
FRONT BRAKE	8-11
HANDLEBAR	8-18
FRONT FORK	8-21
STEERING	8-29
REAR WHEEL	8-36
REAR BRAKE	8-41
REAR SHOCK ABSORBER	8-46
SWINGARM	8-48

EXTERIOR PARTS

⊙ FRONT FENDER

- Loosen the mounting bolts, right and left, and disengage the front fender from the front fork.

NOTE

When removing the front fender, slide the front fender backward.

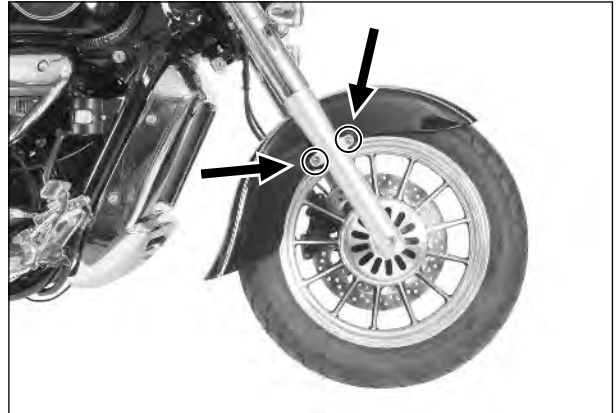

⊙ FRONT SEAT

The front seat lock is located the left side cover under the front seat.

To unlock the front seat, insert the ignition key into the front seat lock and turn it clockwise.

To lock the front seat, push down firmly until the seat latch snaps into the lock position.



⊙ REAR SEAT

To remove the rear seat, loosen the rear seat mounting bolt on the rear side of the rear seat.

To install the rear seat, slide the seat hook into the seat hook retainer and install the rear seat mounting bolt.



⊙ HELMET HOLDER

『ST7』 has the "helmet holder" on the left side pillion rider plate.

To remove the helmet holder, loosen the two bolts from the inside of the seat tail cover.

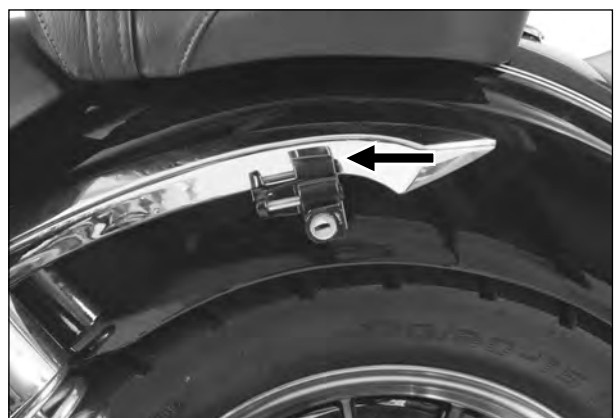

FRAME COVER

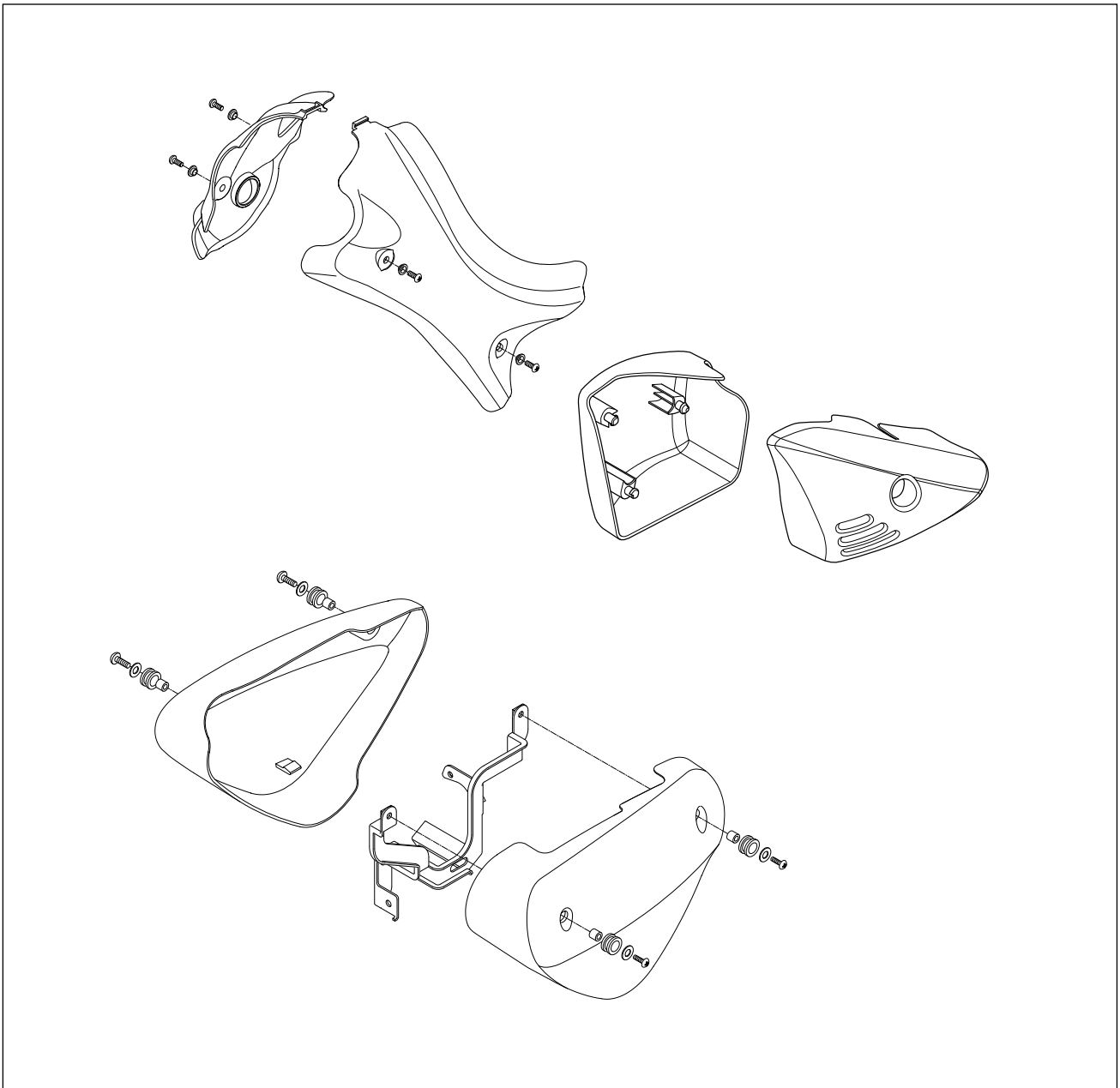

○ FRAME HEAD COVER

- Loosen the two mounting bolts, and disengage the right and left frame head cover from the frame.

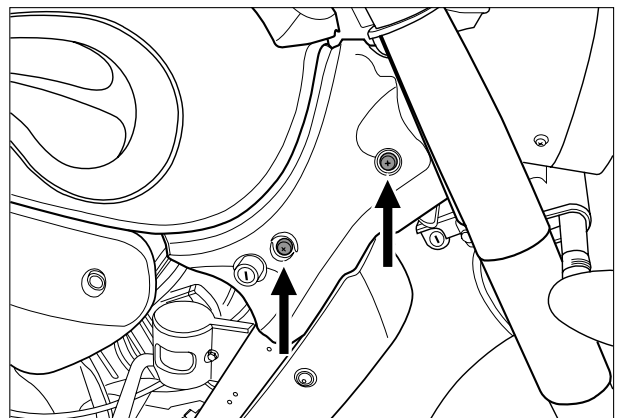

Right



Left

● **AIR CLEANER COVER**

- Loosen the two mounting bolts, and remove the air cleaner cover.

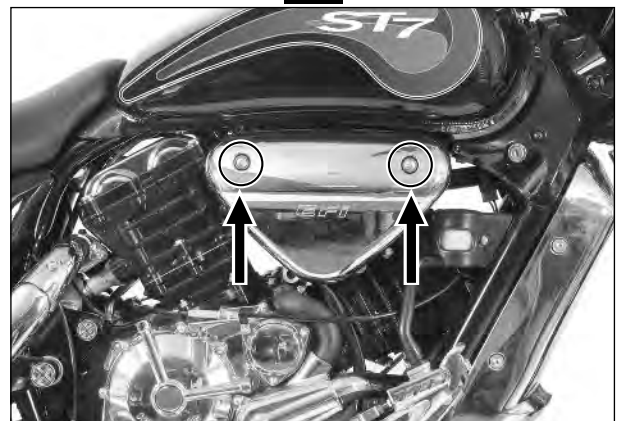

● **FUEL TANK LOWER DECORATION COVER**

- Loosen the two mounting bolts, and remove the fuel tank lower decoration cover.

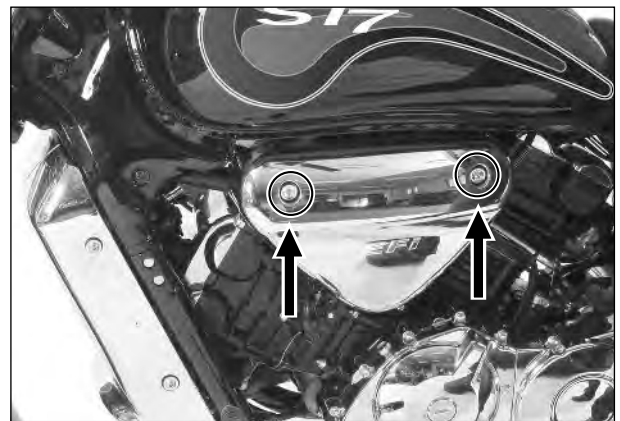

● **SIDE COVER**

- Unhook the three hook, and remove the side cover, right and left.

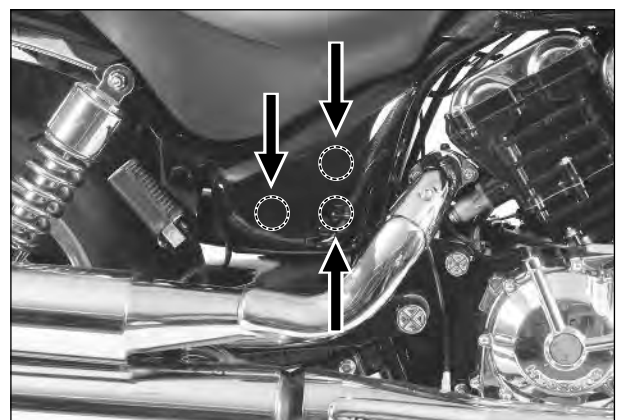
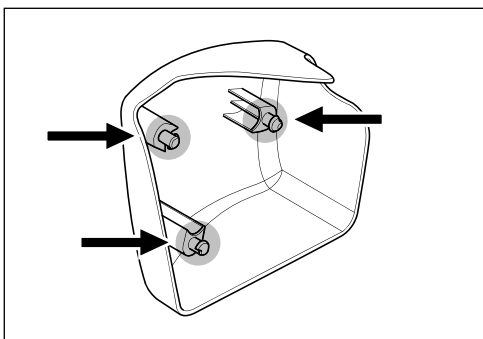

Right

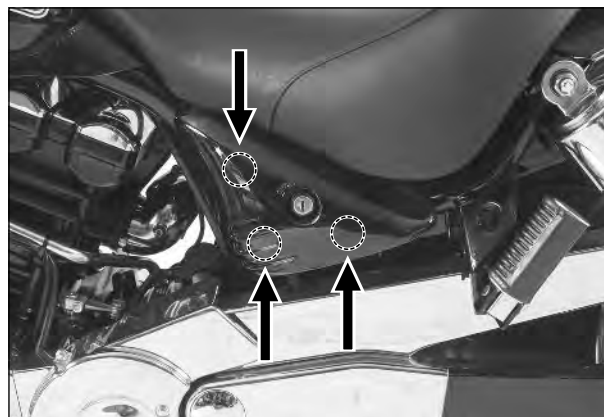

Left

⊙ PILLION RIDER PLATE

- Loosen the two mounting bolts from the inside of the seat tail cover.
- Disengage the right and left pillion rider plate from the seat tail cover.

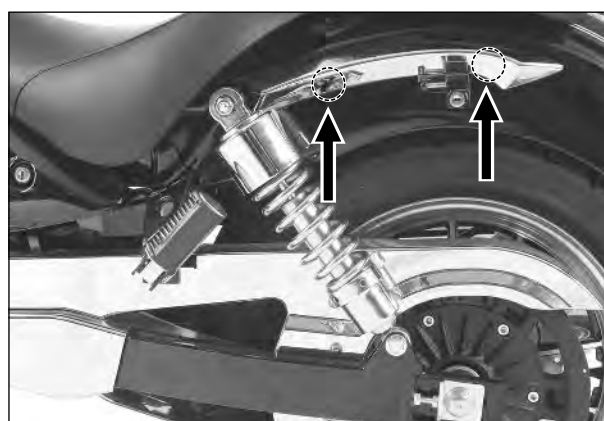
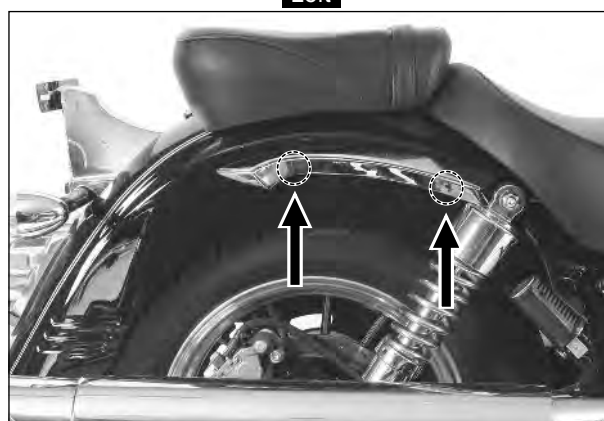

SEAT TAIL COVER & SEAT TAIL COVER BRACE

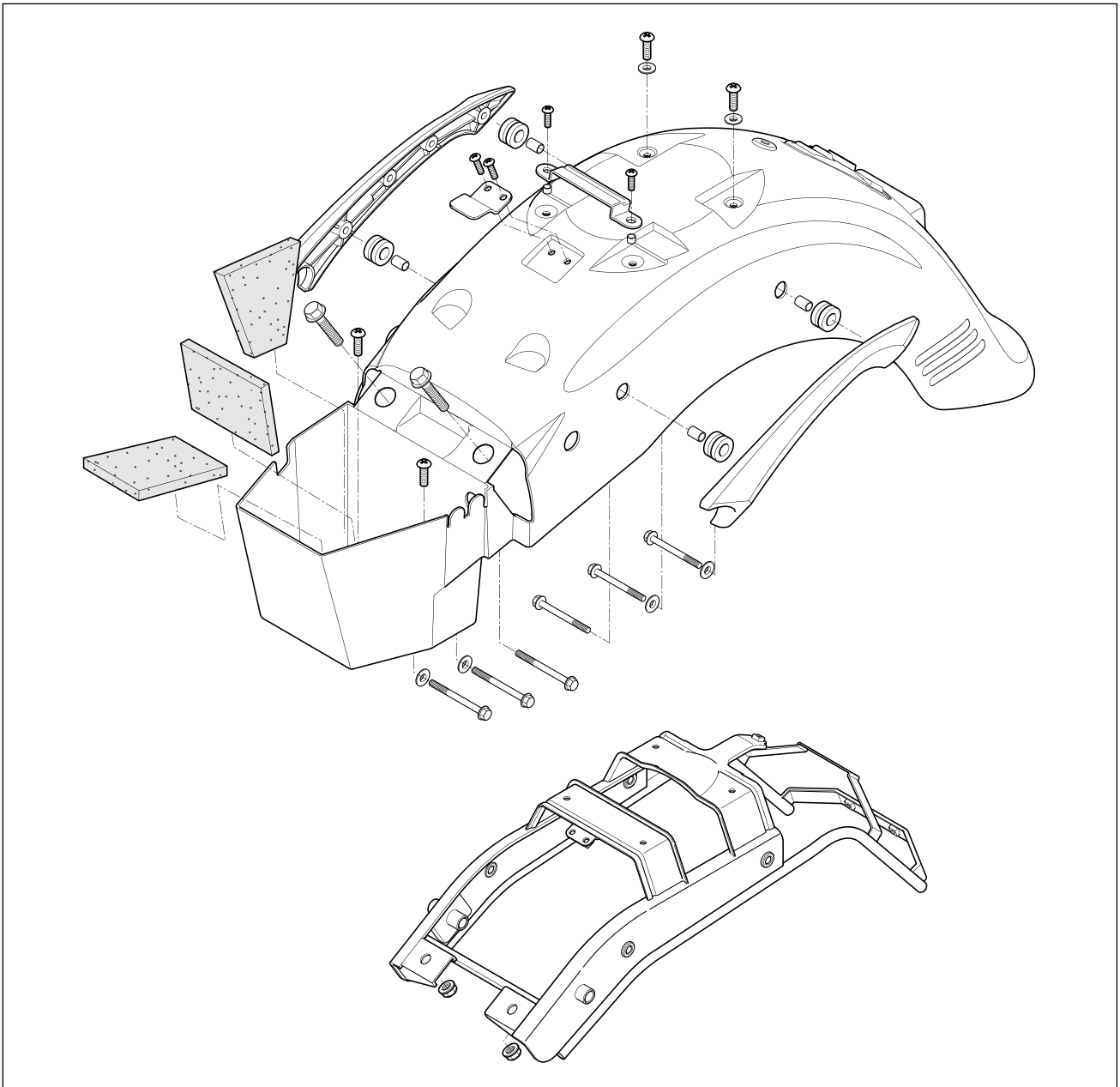

- Remove the front and rear seat. (Refer to page 8-1)
- Remove the rear shock absorber upper bolts from the inside of the frame, right and left.
- Install the rear shock absorber upper bolts with the frame in the outside direction temporarily.



- Remove the battery ①, fuses ②, ③ and ECU ④.
- Disconnect the rear turn signal lamp coupler and rear combination lamp coupler.

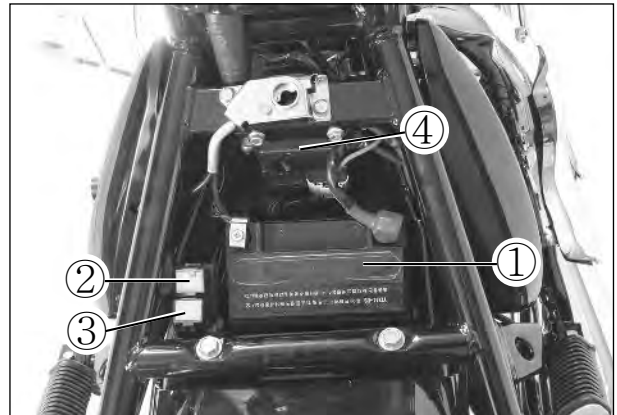

- Remove the two bolts ⑤.

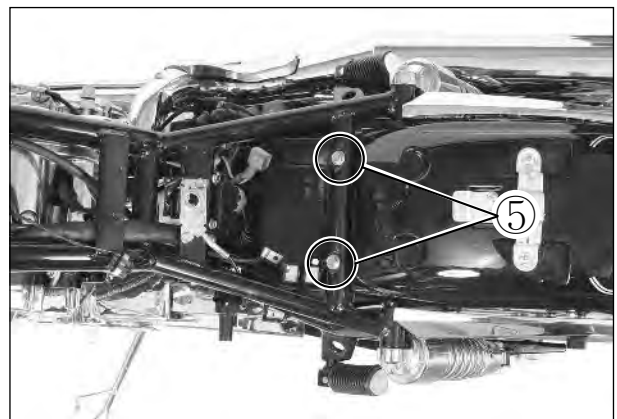

- After loosening the two bolts ⑥, remove the seat tail cover and seat tail cover brace.

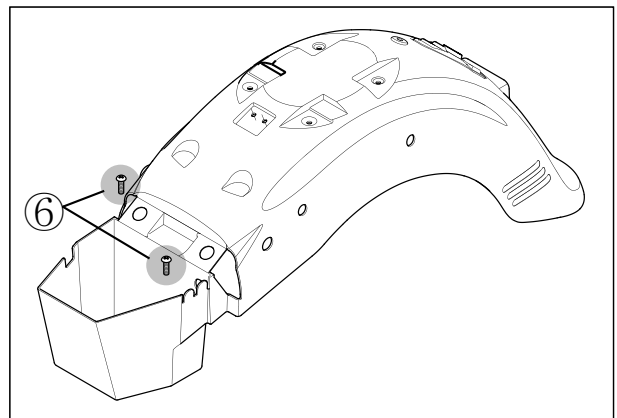

FRONT WHEEL

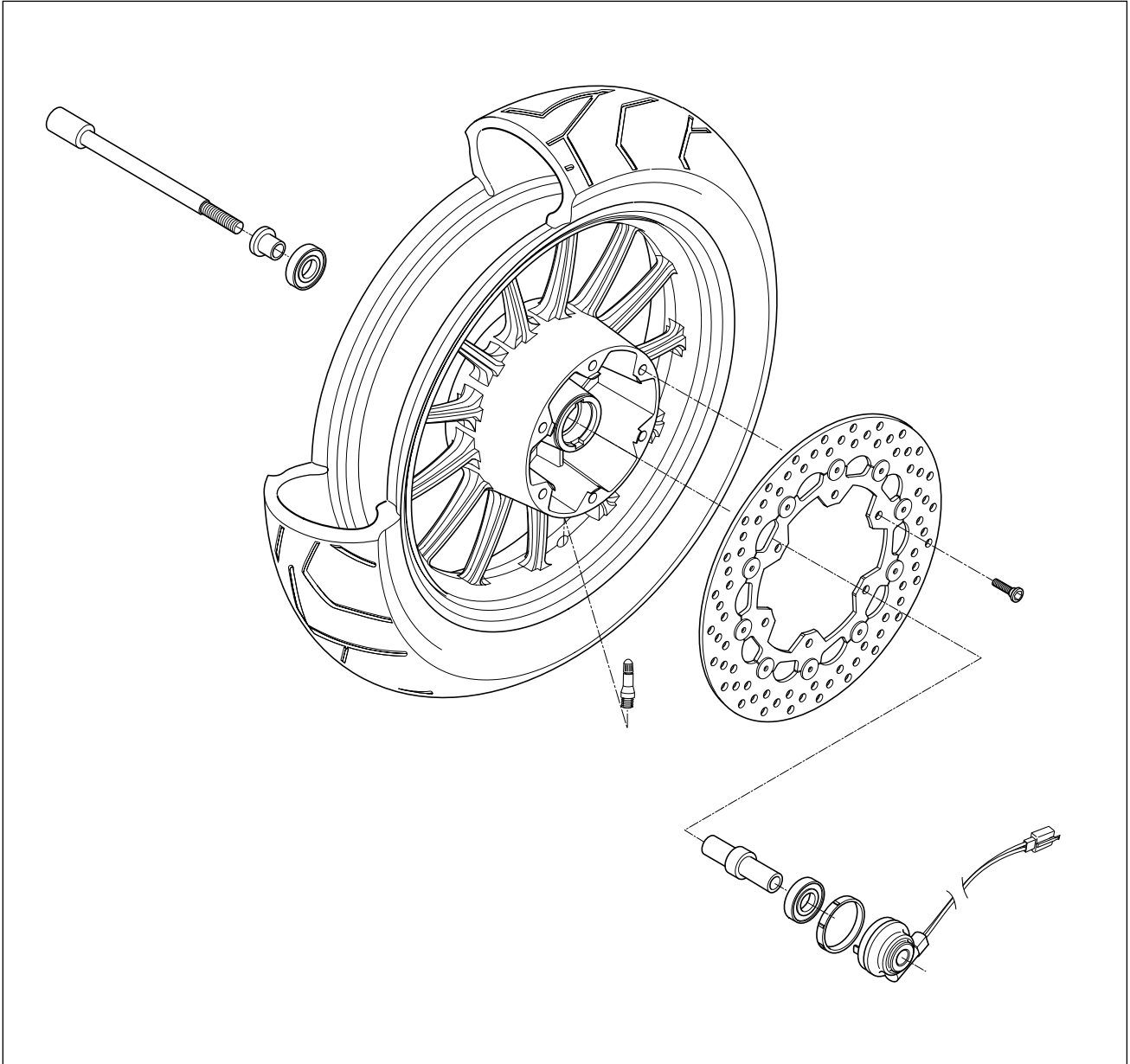

REMOVAL AND DISASSEMBLY

- Remove the front axle pinch bolt cap ①.
- Loosen the front axle pinch bolt (the right side of the motorcycle).
- Loosen the front axle ②.
- Raise the front wheel off the ground with a block or jack.

CAUTION

When using a block or jack, take care not to cause scratches on the chassis and engine.

- Remove the front wheel by removing the front axle ②.

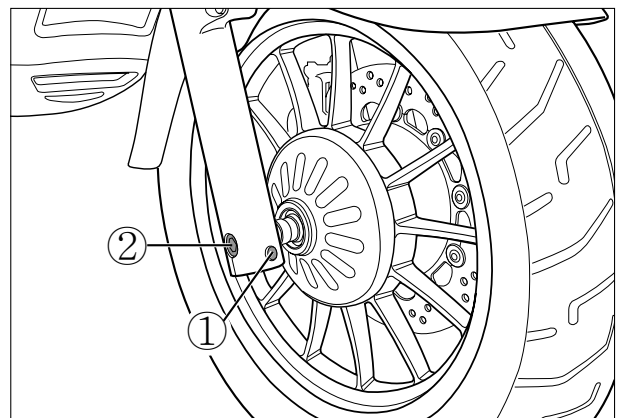

- Remove the brake disk from the left side.



⊙ INSPECTION AND DISASSEMBLY

▣ TIRE

For inspection of the tire : Refer to page 2-23.

▣ FRONT AXLE

Measure the front axle runout using the dial gauge. If the runout exceeds the limit, replace the front axle.

Axle shaft runout	Service limit
	0.25 mm (0.01 in)

 Dial gauge : 09900-20606

Magnetic stand : 09900-20701

V-block : 09900-21304

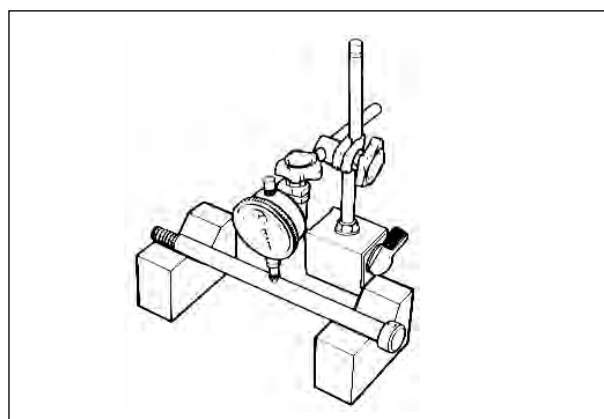

▣ WHEEL RIM

Make sure that the wheel rim runout (axial and radial) does not exceed the service limit when checked as shown. An excessive runout is usually due to worn or loose wheel bearings and can be reduced by replacing the bearings. If bearing replacement fails to reduce the runout, replace the wheel.

Wheel runout (axial and radial)	Service limit
	2.0 mm (0.08 in)

 Dial gauge : 09900-20606

Magnetic stand : 09900-20701



▣ WHEEL BEARING

Inspect the play of the wheel bearings by finger while they are in the wheel. Rotate the inner race by finger to inspect abnormal noise and smooth rotation.

Replace the bearing in the following procedure if there is anything unusual.

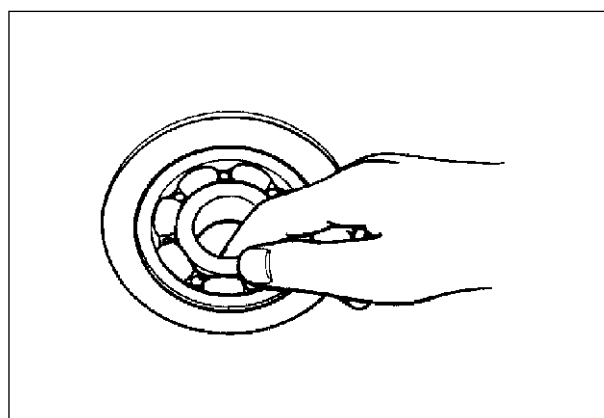

■ **WHEEL BEARING REMOVAL**

- Remove the wheel bearing by using the special tool.

 **Wheel bearing remover : 09941-50111**

 **CAUTION**

The removed bearing should be replaced with new ones.

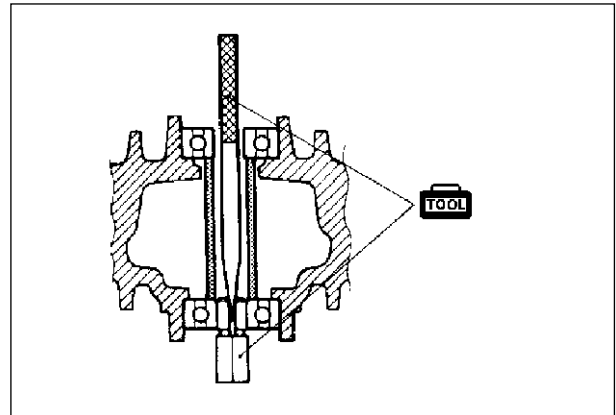

○ **REASSEMBLY AND REMOUNTING**

Reassemble and remount the front wheel in the reverse order of removal and disassembly.

Pay attention to the following points :

■ **WHEEL BEARING**

- Apply **SUPER GREASE "A"** to the wheel bearings before installing.

 **SUPER GREASE "A"**



- Install the wheel bearings as follows by using the special tools.

 **Steering race installer : 09941-34513**

 **CAUTION**

First install the right wheel bearing, then install the left wheel bearing.

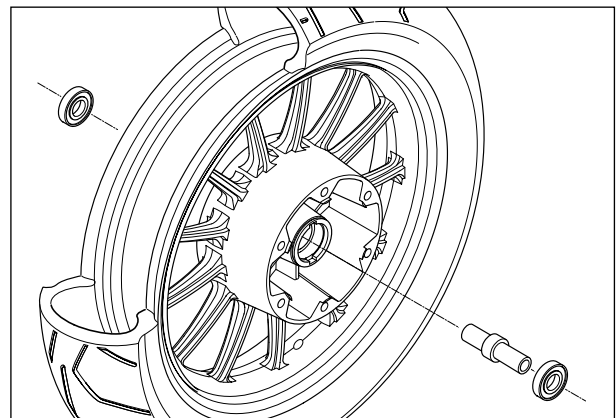

■ **BRAKE DISK**

Make sure that the brake disk is clean and free of any greasy matter.

- Apply **THREAD LOCK "1324"** to the brake disk mounting bolts and tighten them to the specified torque.

 **THREAD LOCK "1324"**

 **Brake disk bolt**
: 18 ~ 28 N · m (1.8 ~ 2.8 kgf · m)



- Tighten the front axle ① and front axle pinch bolt to the specified torque.

**Front axle**

: 50 ~ 80 N · m (5.0 ~ 8.0 kgf · m)

Front axle pinch bolt

: 15 ~ 25 N · m (1.5 ~ 2.5 kgf · m)

- Install the front axle pinch bolt cap ②.

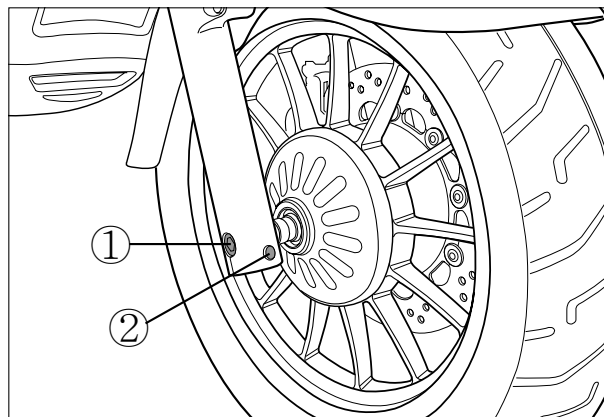

FRONT BRAKE

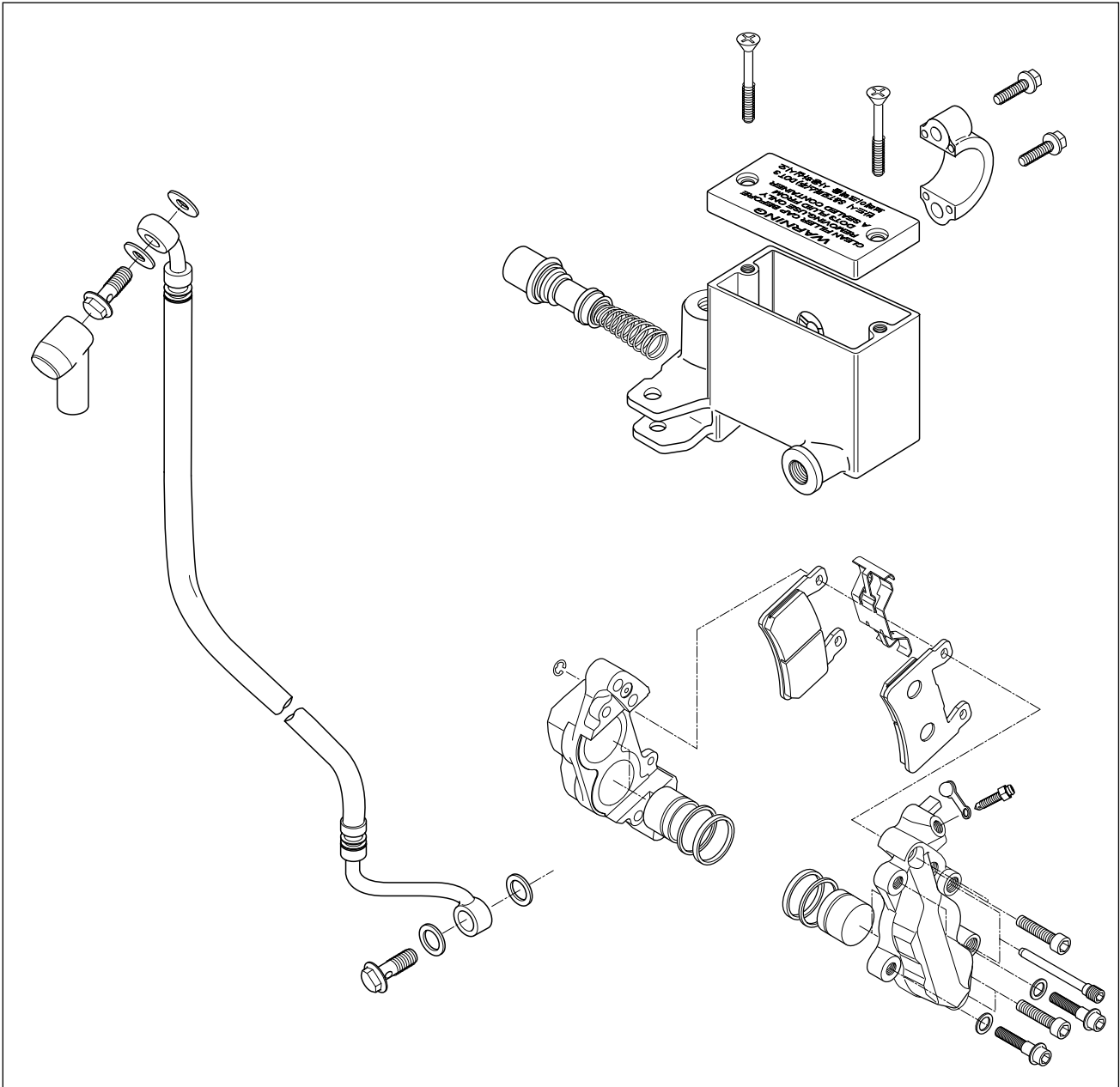

WARNING

- ❖ Do not mix brake fluid with different brand.
- ❖ Do not use a brake fluid kept in an open container or stored for long period of time.
- ❖ To store brake fluid, make sure to seal the container and keep it in a safe place to be out of reach of children.
- ❖ When filling brake fluid, take care not to allow water or dirt to enter the system.
- ❖ To wash the brake system parts, use brake fluid and not any other material.
- ❖ Do not allow dirt and fluid to contact the brake disk or pad.

CAUTION

Do not allow brake fluid to contact the paint surface, plastic or rubber parts, or its chemical reaction can cause discoloration or crack.

⦿ BRAKE FLUID REPLACEMENT

- For replacing procedure of brake fluid : Refer to page 2-19

⦿ BRAKE PAD REPLACEMENT

- For replacing procedure of brake pad : Refer to page 2-18

⦿ CALIPER REMOVAL AND DISASSEMBLY

- Drain brake fluid. (Refer to page 2-19)

⚠ CAUTION

To prevent brake fluid from splashing on the parts nearby, cover the parts with cloth.

- Remove the brake hose from the caliper by loosening the brake union bolt ① and catch the brake fluid in a suitable receptacle.
- Remove the brake pad. (Refer to page 2-18)

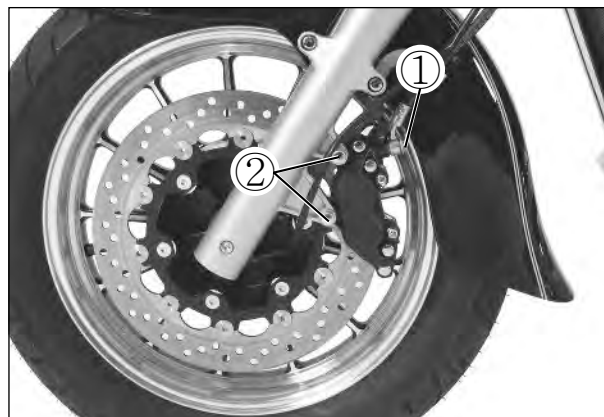

NOTE

Place a rag underneath the union bolt on the brake caliper to catch any spilt brake fluid.

- Remove the caliper mounting bolt caps ②.
- Remove the brake caliper by loosening the caliper mounting bolts.
- Separate the caliper halves by loosening the caliper housing bolts ③.

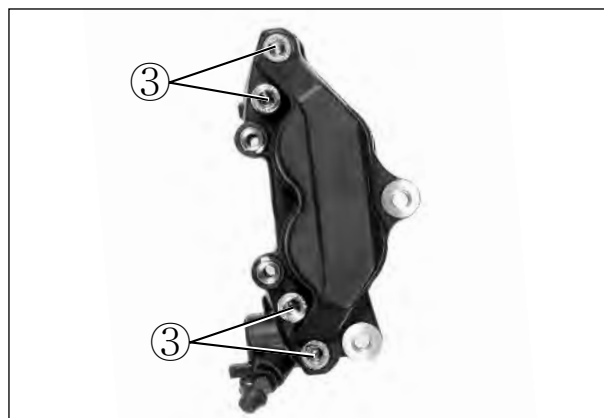

- Remove the O-ring ④.

⚠ CAUTION

Replace the O-ring with the new one.



- Using compressed air, push out the caliper pistons.

⚠ WARNING

- ❖ Place a rag over the pistons to prevent it from popping out and flying and keeping hand off the piston.
- ❖ Be careful of brake fluid which can possibly splash.
- ❖ Do not use high pressure air but increase the pressure gradually.

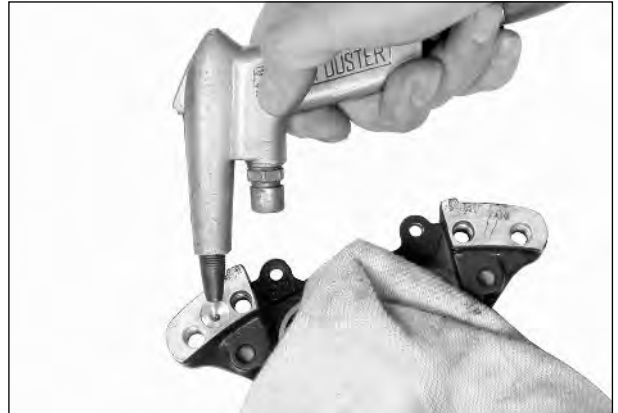

- Remove the dust seals ① and piston seals ②.

⚠ CAUTION

- ❖ Care not to cause scratch on the cylinder bore.
- ❖ Do not reuse the piston seal and dust seal that have been removed.

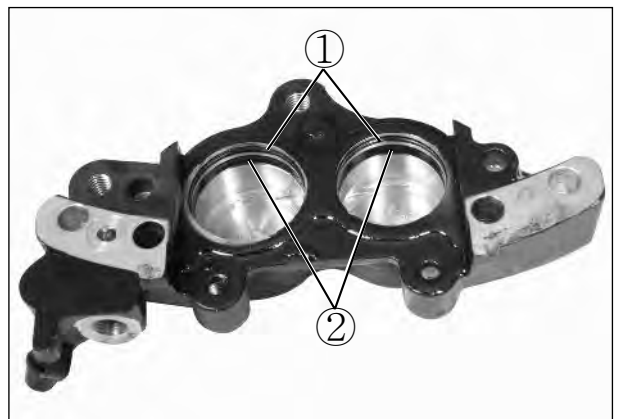

⊙ CALIPER INSPECTION

Inspect the caliper cylinder wall and piston surface for scratch, corrosion or other damages.

If any abnormal condition is noted, replace the caliper.



○ CALIPER REASSEMBLY AND REMOUNTING

Reassemble and remount the caliper in the reverse order of removal and disassembly procedures and observe the following points.

⚠ CAUTION

- ❖ Wash the caliper components with fresh brake fluid before reassembly. Do not wipe off brake fluid after washing the components.
- ❖ When washing the components, use the specified brake fluid. Never use different types of fluid or cleaning solvent such as gasoline, kerosine or the others.
- ❖ Replace the piston seal and dust seal into new ones with brake fluid applied.

 Brake fluid specification and classification : DOT 4

- Install the dust seal and piston seal as shown in the right illustration.

- Install the O-ring ① and put caliper halves together.

- Tighten the caliper housing bolts ② to the specified torque.

 Front brake caliper housing bolt : 40 ~ 45 N · m (4.0 ~ 4.5 kgf · m)

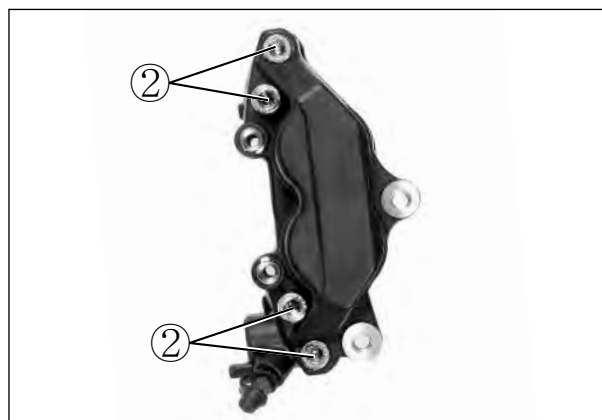
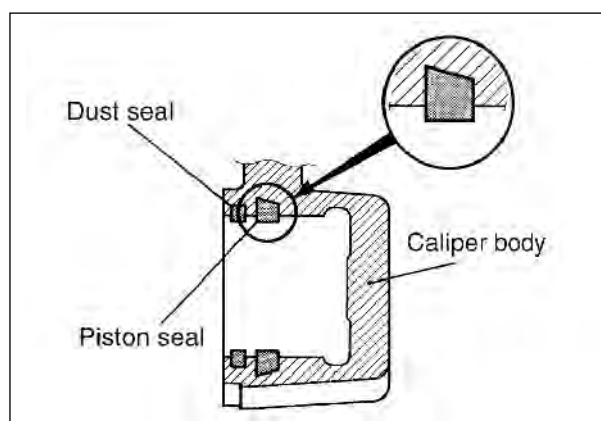
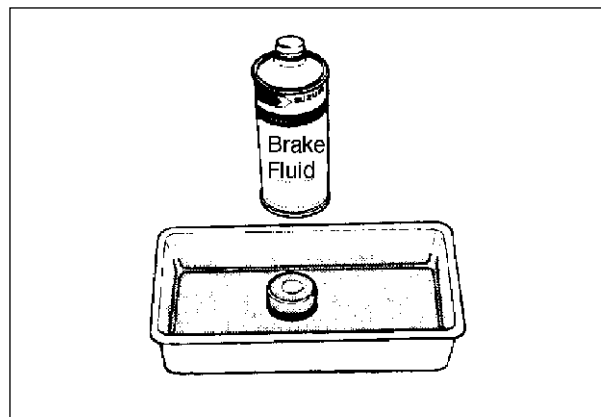

- Tighten the caliper mounting bolts and brake hose union bolt ① to the specified torque.

Front brake caliper mounting bolts
: 18 ~ 28 N · m (1.8 ~ 2.8 kgf · m)

Front brake hose union bolts
: 20 ~ 25 N · m (2.0 ~ 2.5 kgf · m)

NOTE

Before remounting the caliper, push the piston all the way into the caliper.

- Install the caliper mounting bolt caps ②.
 - Fill the system with brake fluid and bleed air. (Refer to page 2-20)
- Inspection after reassembly : Refer to page 2-17

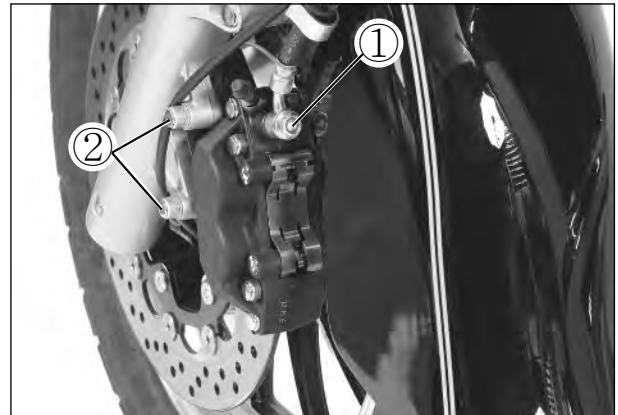

⊙ **BRAKE DISK INSPECTION**

Visually check the brake disk for damage or cracks. Measure the thickness using the micrometer. Replace the brake disk if the thickness is less than the service limit or if damage is found.

Brake disk thickness	Service limit
	3.0 mm (0.12 in)

TOOL Micrometer (0 ~ 25 mm) : 09900-20201



Measure the runout using the dial gauge. Replace the brake disk if the runout exceeds the service limit.

Brake disk runout	Service limit
	0.3 mm (0.012 in)

TOOL Dial gauge : 09900-20606
Magnetic stand : 09900-20701

- If measurement exceeds the service limit, replace the brake disk. (Refer to page 8-8)



⊙ MASTER CYLINDER REMOVAL AND DISASSEMBLY

- Drain brake fluid the master cylinder.
- Disconnect the brake lamp switch lead wire coupler.
- Remove the union bolt ①.



CAUTION

Place a rag under the union bolt so that brake fluid can not contact the parts.



- Remove the two clamp bolts and take off the master cylinder.

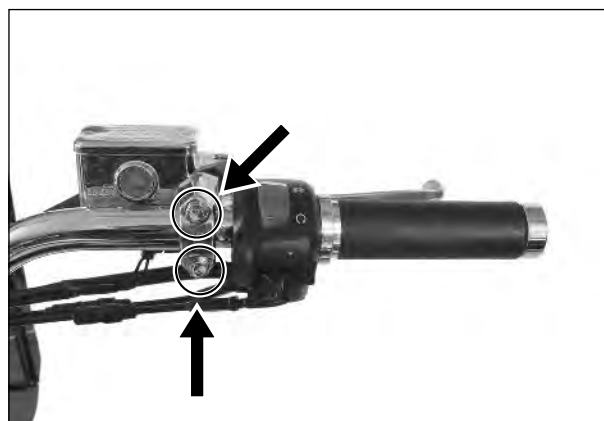

- Remove the two fitting screws and separate the cap and diaphragm.



- Detach the dust seal boot ② and remove the circlip.
- Pull out the piston/cup set ③ and spring ④.

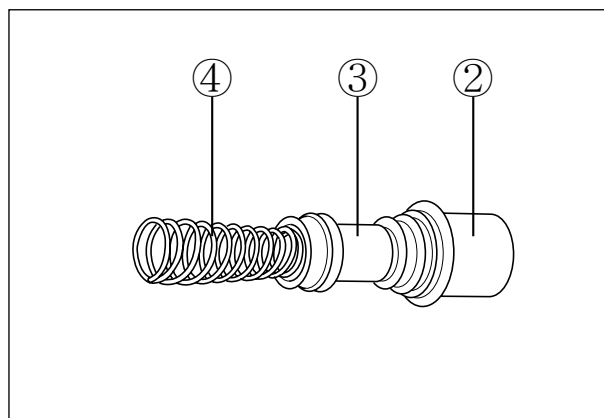

● MASTER CYLINDER INSPECTION

Inspect the master cylinder bore for any scratches or other damage.
 Inspect the piston surface for any scratches or other damage.

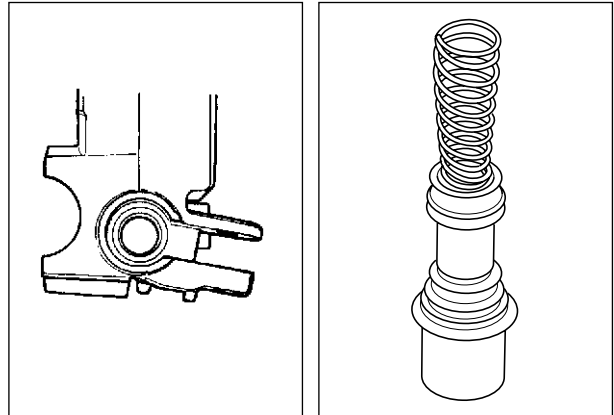

● MASTER CYLINDER REASSEMBLY AND REMOUNTING

Reassemble the master cylinder in the reverse order of removal and disassembly.

Pay attention to the following points :

⚠ CAUTION

- ❖ Wash the master cylinder components with new brake fluid before reassembly.
- ❖ When washing the components, use the specified brake fluid. Never use different types of fluid or cleaning solvents such as gasoline, kerosine, etc.

BF Brake fluid specification and classification : DOT 4

NOTE

When installing the circlip, make sure that the sharp edge of the circlip faces outside.

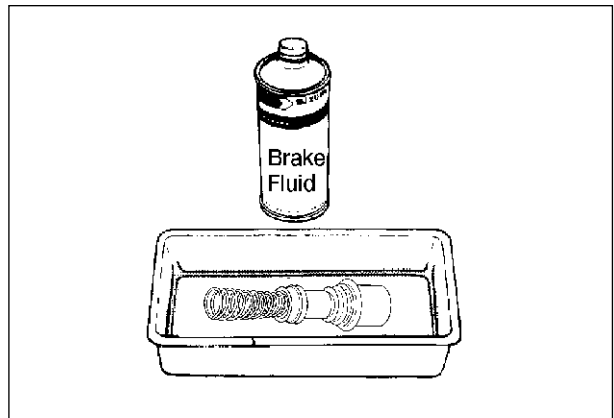

- When remounting the master cylinder to the handlebars, first tighten the clamp bolts for upside as shown.

⚠ WARNING

Bleed air from the brake fluid circuit after assembling master cylinder. (Refer to page 2-20)

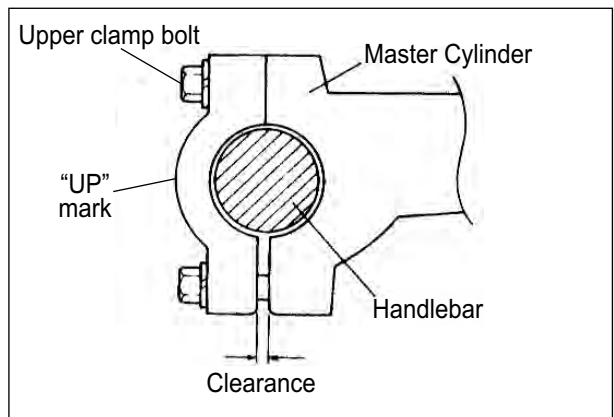

HANDLEBAR

○ HANDLEBAR RIGHT SIDE PARTS REMOVAL AND DISASSEMBLY

- Remove the right handlebar switches.
- Disconnect the brake lamp switch lead wires and remove the master cylinder.
(Refer to page 8-16)
- Remove the handlebar balancer ① and grip ②.

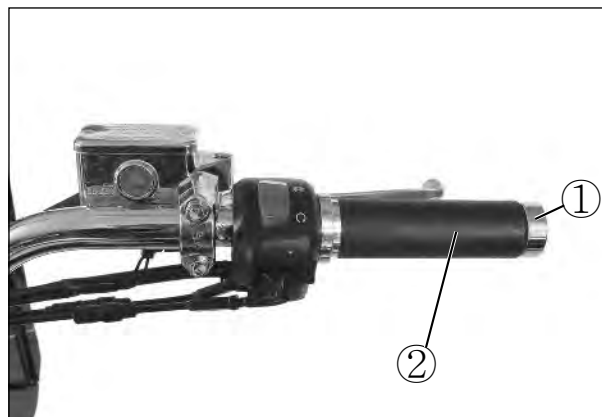

○ HANDLEBAR LEFT SIDE PARTS REMOVAL AND DISASSEMBLY

- Remove the left handlebar switches.
- Remove the handlebar balancer ③ and grip ④.
- Remove the clutch lever holder.

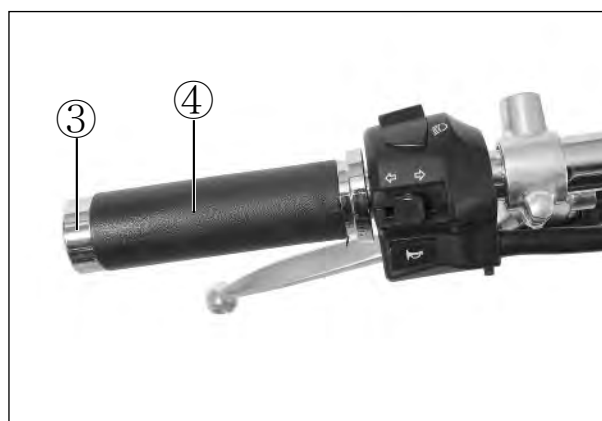

- Remove the handlebar clamp bolt caps.
- Remove the handlebar clamp bolts and detach the handlebar.

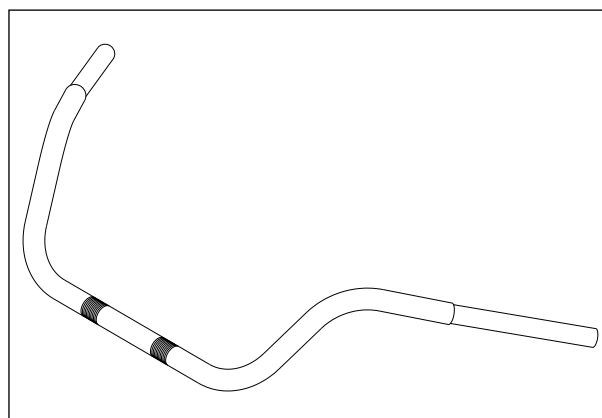

⊙ REASSEMBLY AND REMOUNTING

Perform the reassembly and remounting work in the reverse order of the removal and disassembly procedures while observing the following instructions.

- Install the punch mark ① of the handlebar aligned with the handlebar clamp as shown.



- Tighten the handlebar clamp bolts to the specified torque.



Handlebar clamp bolts

: 18 ~ 28 N · m (1.8 ~ 2.8 kgf · m)

- Install the handlebar clamp bolt caps.

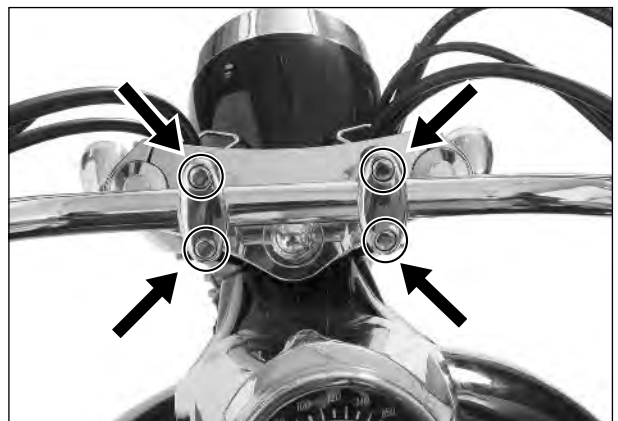

- When remounting the right and left handle switches, engage the stopper ② with the handlebar hole ③.

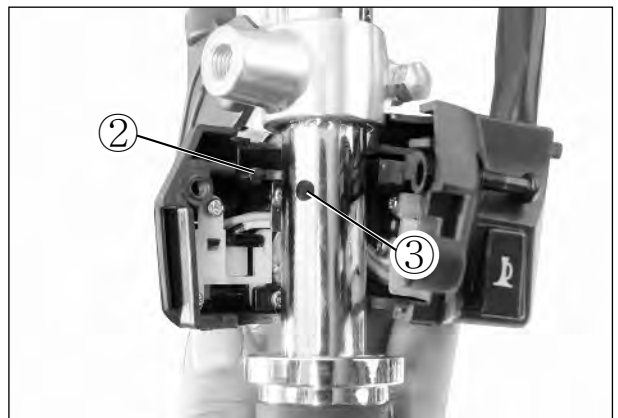

- Align the mating face of clutch lever holders with the respective punch marks and tighten the bolt.
- Install the brake master cylinder.
(Refer to page 8-17).

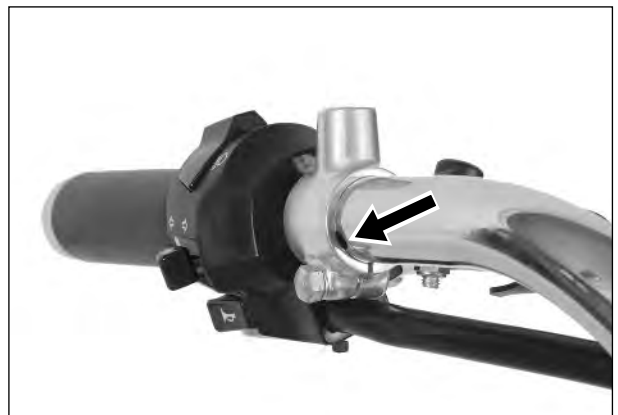

- Apply **SUPER GREASE "A"** to the throttle cables.

 **SUPER GREASE "A"**

- Install the throttle cable and returning cable to the throttle grip ①, ②.

- ① : Throttle cable
- ② : Returning cable

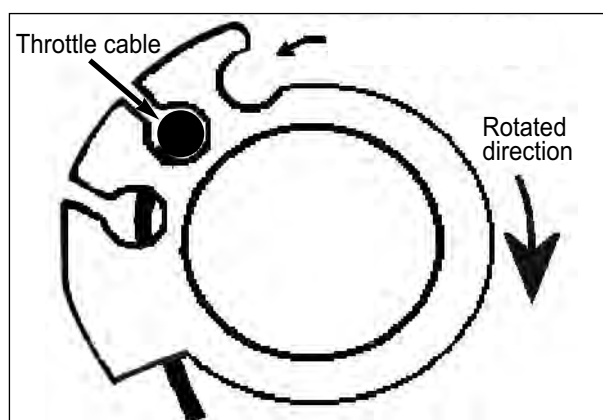
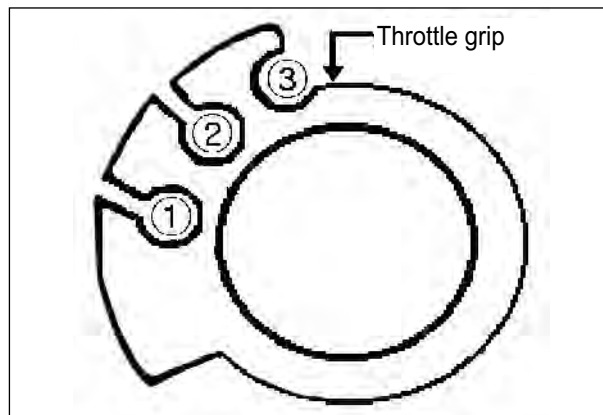

FRONT FORK

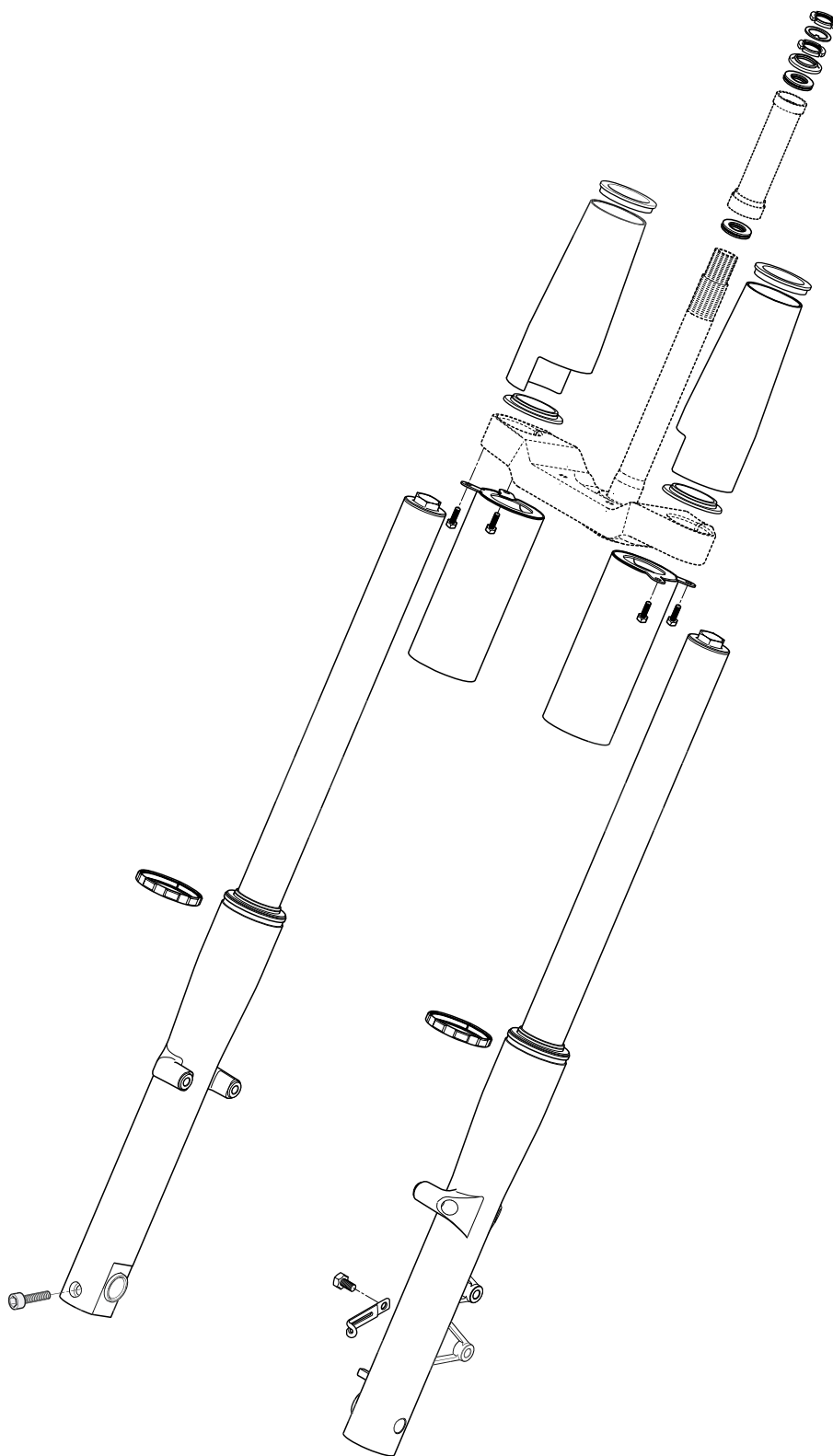

⊙ REMOVAL AND DISASSEMBLY

- Remove the front fender. (Refer to page 8-1)
- Take off the front wheel. (Refer to page 8-7)
- Remove the brake caliper. (Refer to page 8-12)

⚠ CAUTION

Secure the brake caliper to the frame with a string etc., taking care not to bend the brake hose.



- Remove the front fork after loosening the front fork upper ① and lower ② clamp bolts .

NOTE

Slightly loosen the front fork cap bolt ③ to facilitate later disassembly.

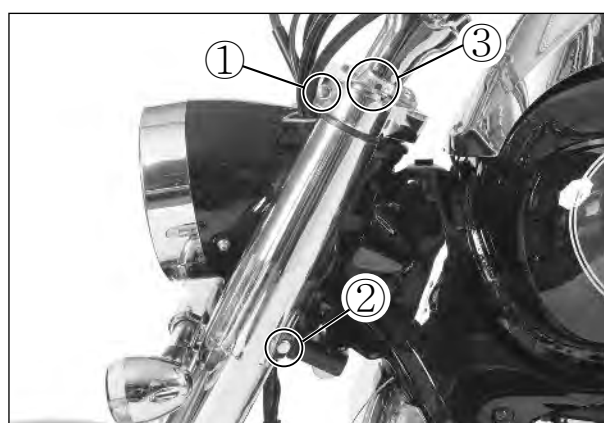

- Remove the front fork cap bolt ③, O-ring ④ and front fork inner spacer ⑤.

⚠ CAUTION

Do not disassemble the front fork cap ③.

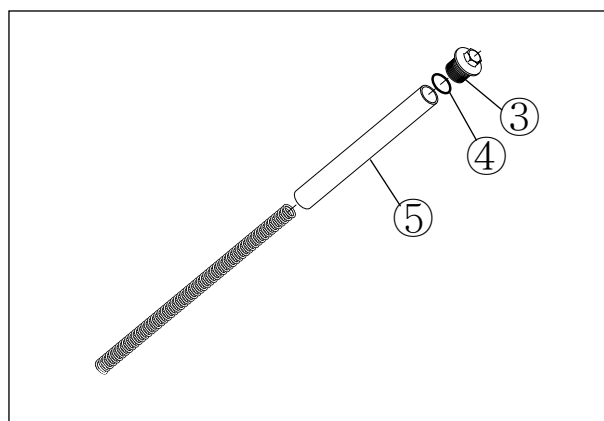

- Invert the front fork and stroke it several times to drain out the fork oil.
- Hold the front fork in the inverted position for a few minutes to allow the fork oil to fully drain.

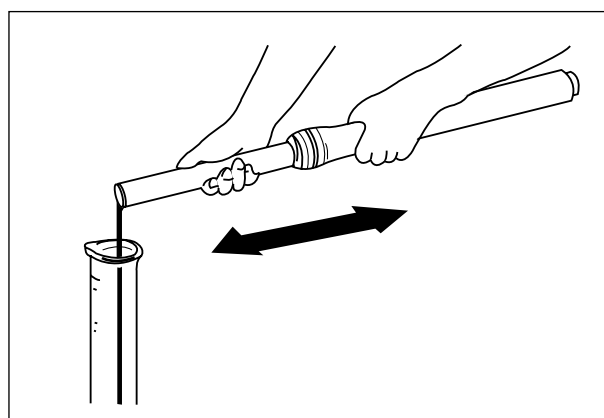

8-23 CHASSIS

- With the damper rod held immovable, remove the damper rod bolt ①.



- Remove the damper rod ② and rebound spring ③ from the inner tube.

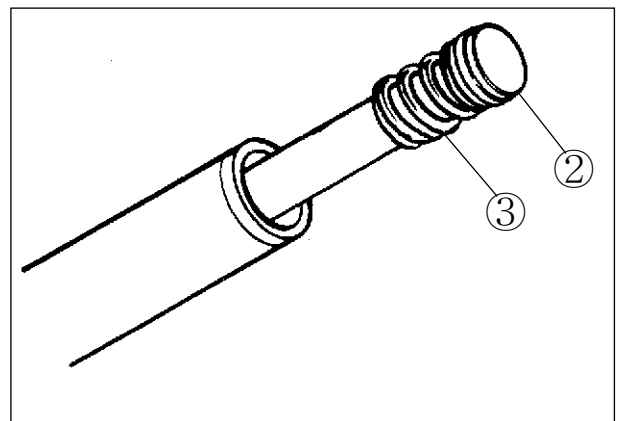

- Remove the dust seal ④ and oil seal stopper ring ⑤.

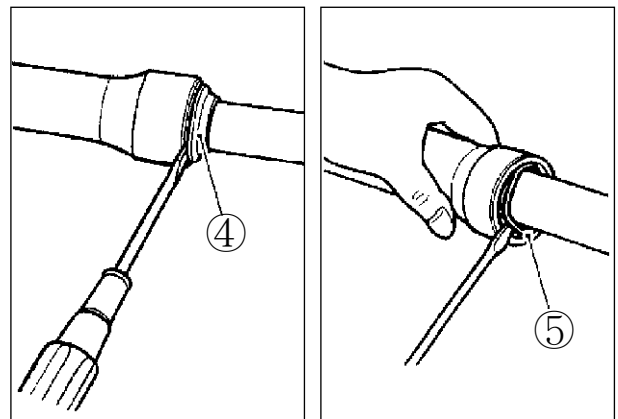

- Separate the inner tube from the outer tube.

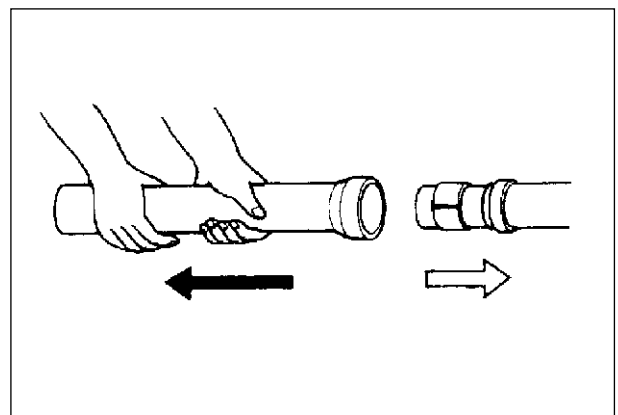

● Remove the following parts.

- ① Oil seal
- ② Slide metal
- ③ Oil lock piece

⚠ CAUTION

The removed oil seal and slide metal should be replaced with new ones.

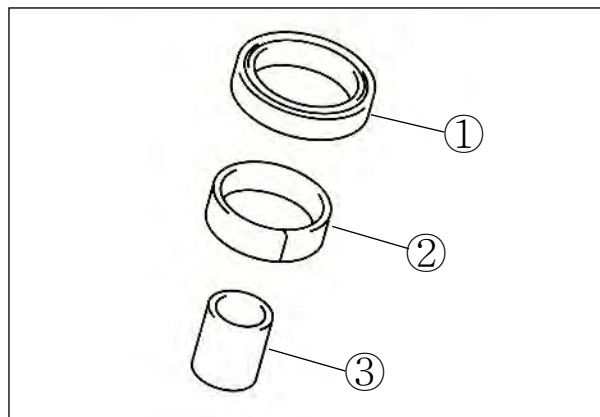

- Loosen the front fork cover bolt.
- Remove the front fork cover.



⊙ INSPECTION
▣ FRONT FORK SPRING

Measure the free length **A** of the front fork spring.
 If the length is found shorter than the service limit,
 replace the spring.

Front fork spring free length A	Service limit 321 mm (12.6 in)
---	-----------------------------------

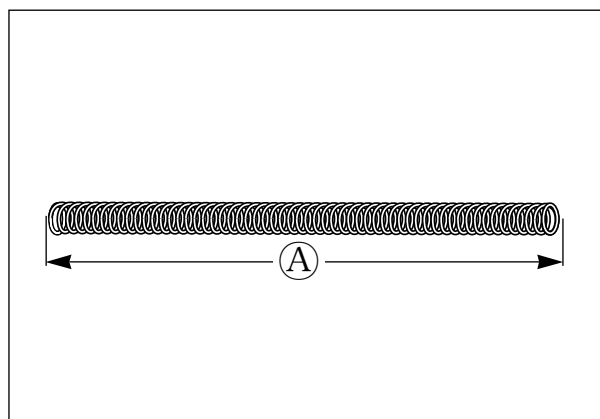

▣ INNER AND OUTER TUBE

Inspect the inner tube outer surface and outer tube slide metal **④** face for scratches.
 If any defects are found, replace them with a new one.

⚠ CAUTION

Don't remove the outer tube slide metal **④**.

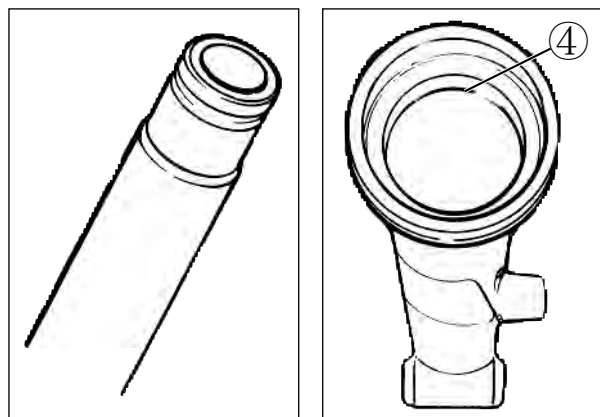

⊙ REASSEMBLY AND REMOUNTING

Reassemble and remount the front fork in the reverse order of removal and disassembly.

Pay attention to the following points :

⚠ CAUTION

- ❖ Thoroughly wash all the component parts being assembled.
Insufficient washing can result in oil leakage or premature wear of the parts.
- ❖ When reassembling the front fork, use new fork oil.
- ❖ Use the specified fork oil for the front fork.
- ❖ When reassembling, replace the oil seal, dust seal and damper rod bolt gasket with new ones.

● On the inner tube, assemble the following parts.

- ① Dust seal
- ② Oil seal stopper ring
- ③ Oil seal
- ④ Oil seal retainer
- ⑤ Slide metal
- ⑥ Guide bushing

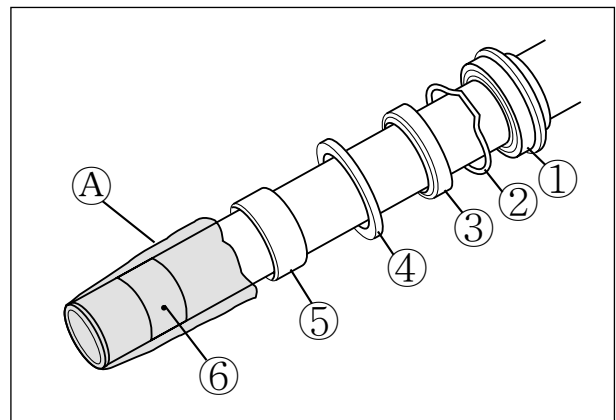

⚠ CAUTION

To prevent the lip of oil seal ③ from being damaged, cover the inner tube with vinyl sheet ④ during installation.

● With the oil lock piece fitted to the inner tube, assemble the inner tube to the outer tube.

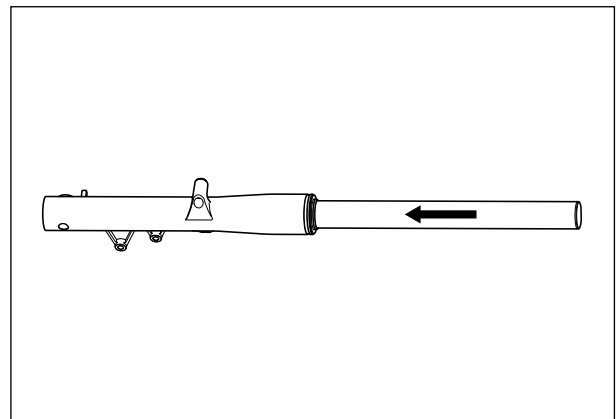

● Apply **SUPER GREASE "A"** to the lip of the oil seal ③ and install it into the outer tube using the front fork oil seal installer.

 **SUPER GREASE "A"**

 **Front fork oil seal installer set**

: 09940-52861

⚠ CAUTION

Wash and clean the front fork oil seal installer before using. If dirt is on the installer, the inner tube may possibly be damaged during press-fitting work.

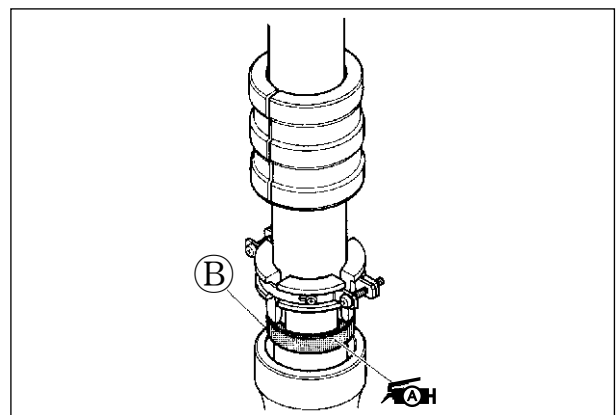

- Fit the stopper ring ② and dust seal ①.

 CAUTION
<p>Make sure that the stopper ring is securely fitted into the groove on the outer tube.</p>

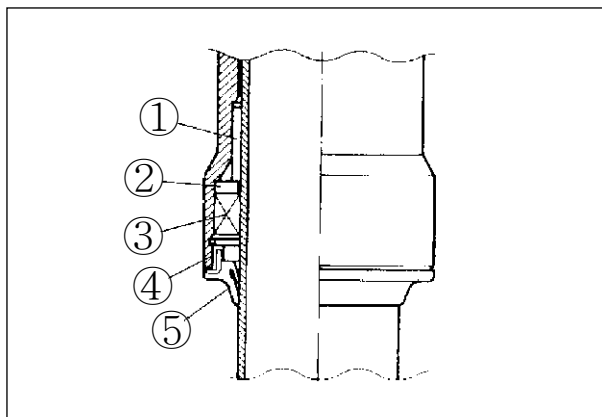

- ① Dust seal
- ② Oil seal stopper ring
- ③ Oil seal
- ④ Oil seal retainer
- ⑤ Slide metal

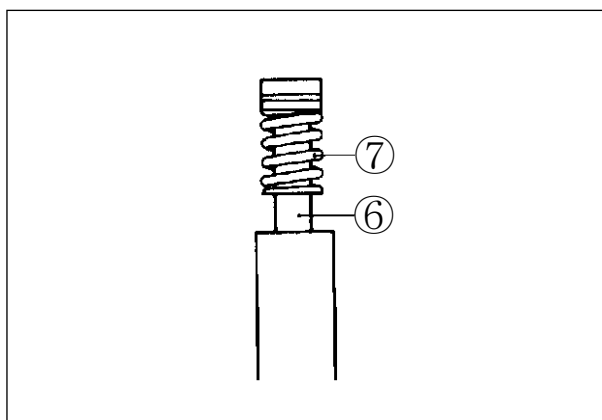

- Fit the rebound spring ⑦ on the damper rod ⑥ and install them together to the inner tube.



- Apply **THREAD LOCK "1324"** to the damper rod bolt ⑨.
- With the damper rod held immovable, with the gasket ⑧ fitted, tighten the damper rod bolt ⑨.

 **Front fork damper rod bolt**
 : 20 ~ 30 N · m (2.0 ~ 3.0 kgf · m)
 **THREAD LOCK "1324"**

 CAUTION
<p>Replace the gasket with a new one.</p>

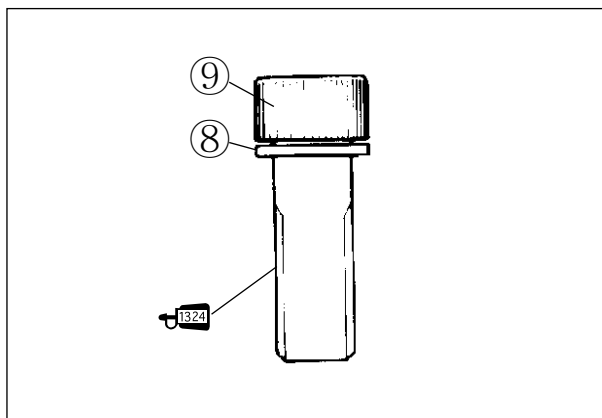

FRONT FORK OIL

- With the inner tube in fully compressed position, pour the specified amount of fork oil and stroke the tube several times to expel air.

 **Front fork oil specification**
 : **TELLUS #32**

Front fork oil capacity	Each leg 370 ± 4 cc
--------------------------------	------------------------

- With the front fork held in vertical position, compress the inner tube all the way.

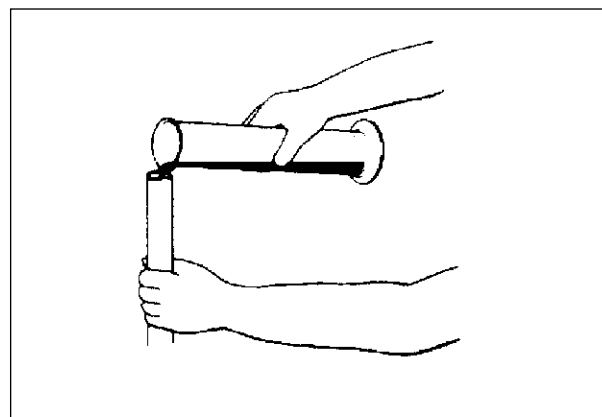

8-27 CHASSIS

- Wait until the fluid level stabilizes, measure and adjust the level to specification using the special tool.

	Standard
Front fork oil level	136 mm (5.4 in) from end of outer tube (When maximum compressed without spring)

 **Front fork oil level gauge : 09943-74111**

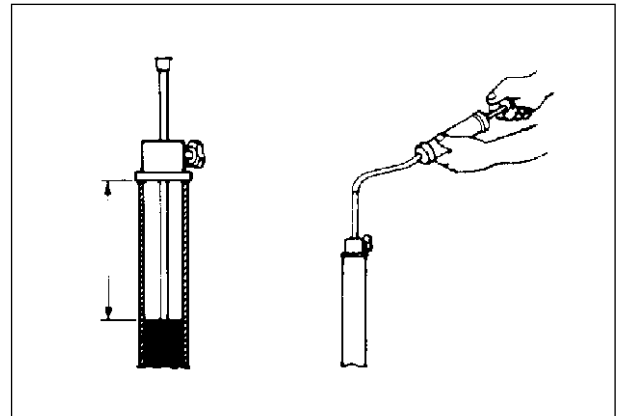

- Install the front fork spring ①.
- Install the front fork inner spacer ② and O-ring ③.

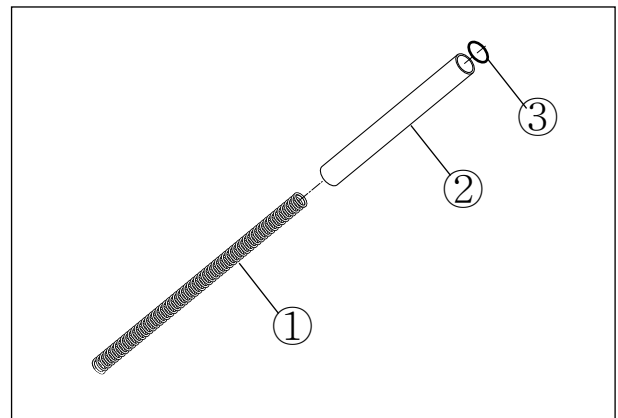

- Fit the O-ring to the front fork cap bolt and apply **SUPER GREASE "A"**.

 **SUPER GREASE "A"**

 **CAUTION**

Use a new O-ring to prevent oil leakage.



- Install the front fork to the motorcycle.
- Align the upper surface of the inner tube with the upper surface of the steering stem upper bracket.



- Tighten the front fork lower clamp bolts ① and front fork upper clamp bolts ② to the specified torque.
- Tighten the front fork cap bolts ③ to the specified torque.



Front fork upper clamp bolt

: 22 ~ 35 N · m (2.2 ~ 3.5 kgf · m)

Front fork lower clamp bolt

: 22 ~ 35 N · m (2.2 ~ 3.5 kgf · m)

Front fork cap bolt

: 20 ~ 30 N · m (2.0 ~ 3.0 kgf · m)

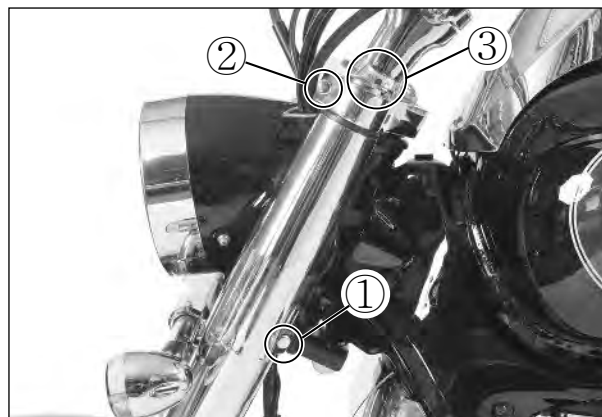

- Install the front fender and tighten the mounting bolts temporarily.



CAUTION

When installing the front fender, install the front brake hose guide ④ to left side of the front fender.

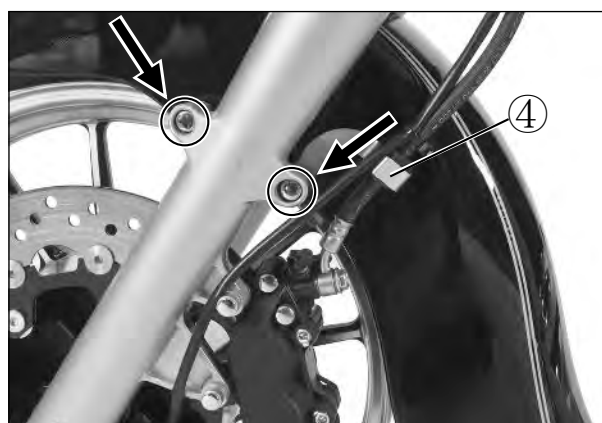

- Install the front wheel. (Refer to page 8-9)
- Install the front brake caliper. (Refer to page 8-14)
- Move the front fork up and down several times.
- Tighten the front fender mounting bolts securely.



STEERING

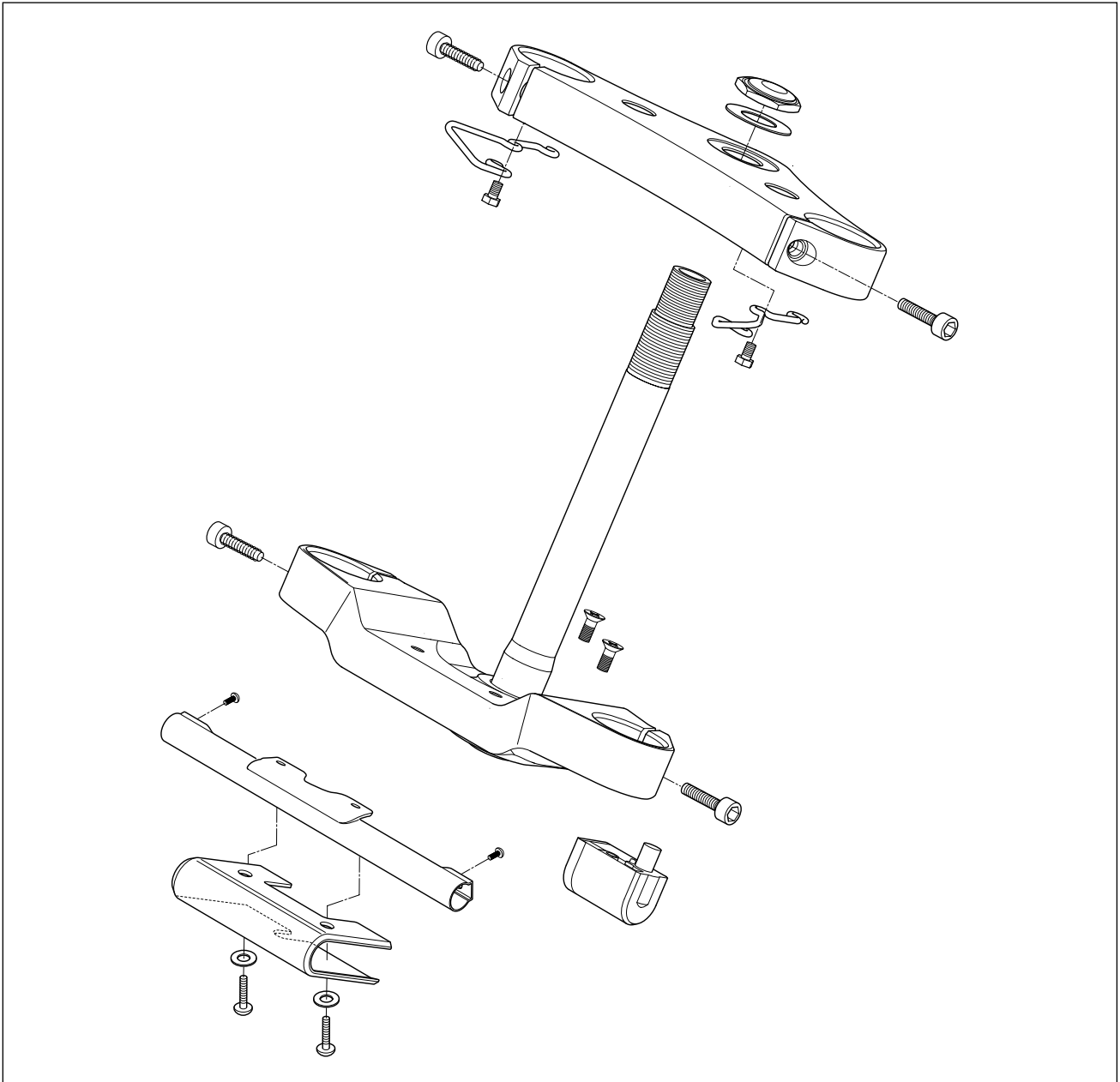

● REMOVAL AND DISASSEMBLY

- Take off the front wheel. (Refer to page 8-7)
- Remove the front fender. (Refer to page 8-1)
- Take off the front fork. (Refer to page 8-22)



- Remove the front turn signal lamp assembly.

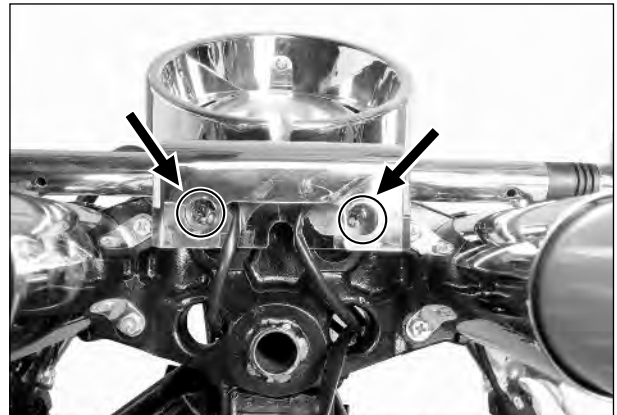

- Remove the handlebars. (Refer to page 8-18)

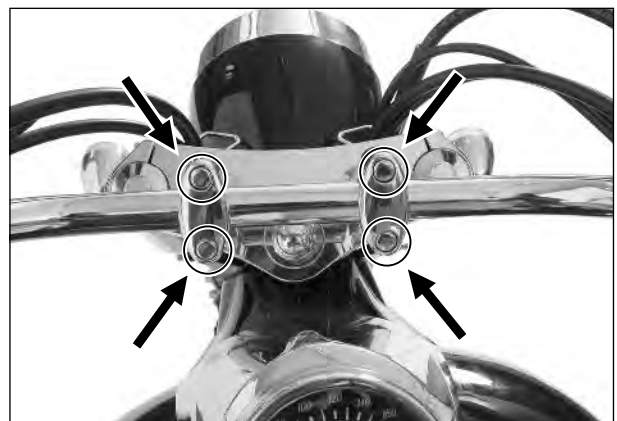

- Remove the steering stem head nut ①.
- Remove the steering stem upper bracket ②.

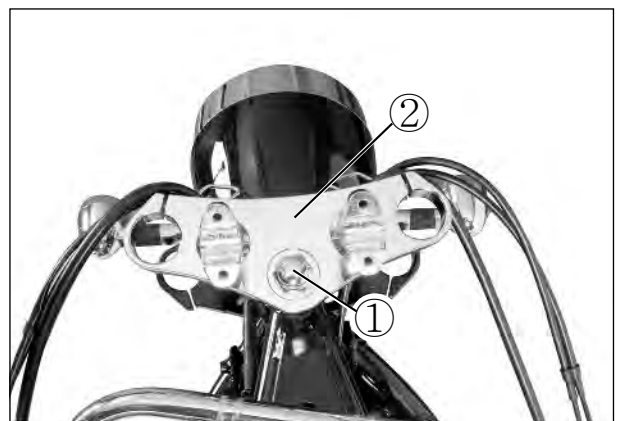

- Remove the steering stem upper nut ③ and steering stem nut ④ using the special tool.

 **Clamp wrench : 09940-10122**

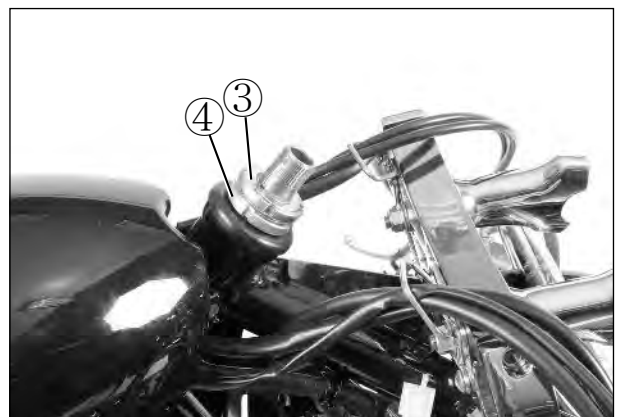



- Take off the steering stem lower bracket ①.

⚠ CAUTION

Hold the steering stem lower bracket by hand to prevent from falling.

- Remove the upper and lower bearing ②.

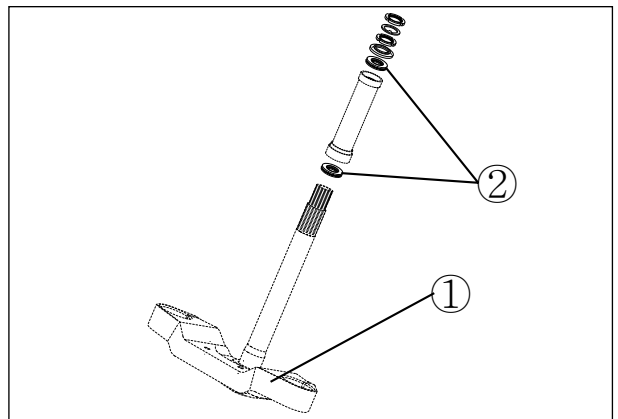

- Remove the handlebar holders by removing the nuts.

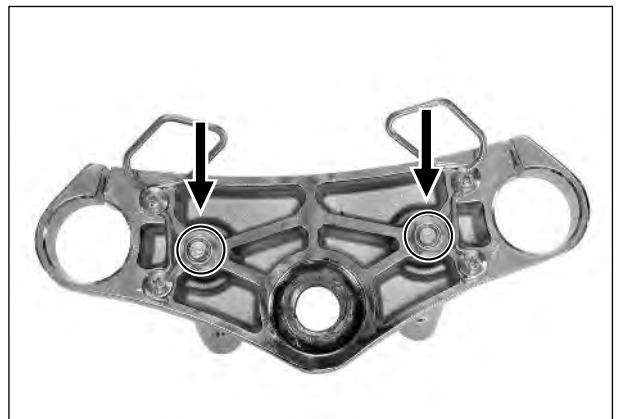

- Draw out the steering stem upper and lower bearing outer races using the steel rod.

⚠ CAUTION

The removed bearing outer race must be replaced with a new one.

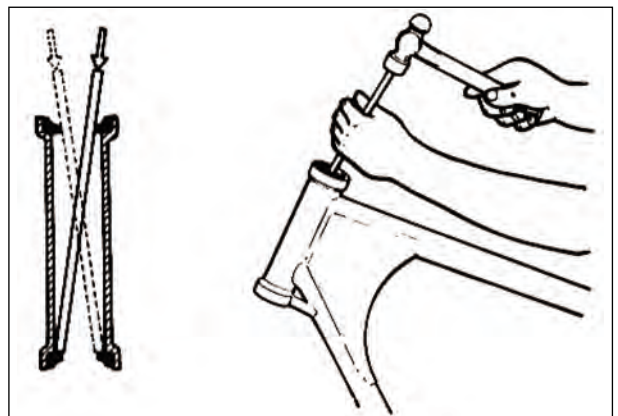

⊙ INSPECTION

Inspect and check the removed parts for the following abnormalities.

- *Handlebar distortion.
- *Handlebar holder wear.
- *Abnormality operation of bearing.
- *Distortion of steering stem.
- *Bearing wear or damage.
- *Race wear or damage.

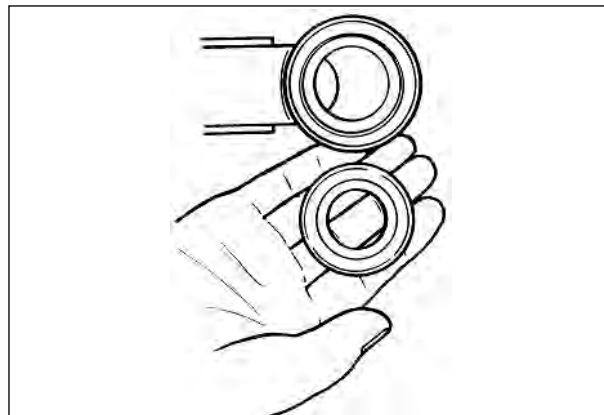

⊙ REASSEMBLY AND REMOUNTING

Reassemble and remount the steering stem in the reverse order of removal and disassembly.

However, operate the work taking care for the following points.

- Press in the steering stem upper and lower bearing outer races using the special tool.

 **Steering race installer : 09941-34513**

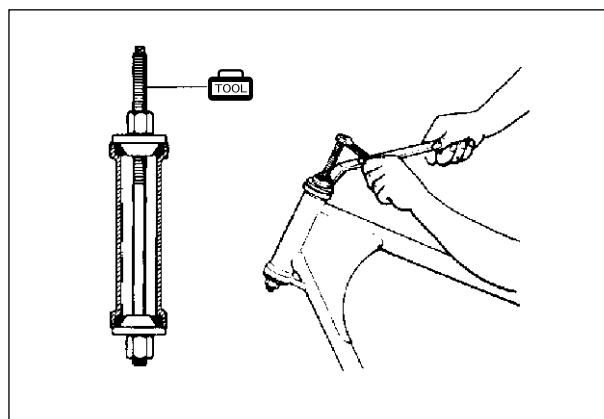

- Apply **SUPER GREASE "A"** to the steering stem lower bearing prior to installing the steering stem.

 **SUPER GREASE "A"**

- Press in the steering stem lower bearing ①.



- Apply **SUPER GREASE "A"** to the steering stem upper bearing prior to installing the steering stem.

 **SUPER GREASE "A"**

- Install the steering stem upper bearing ②.
- Install the dust cover ③.

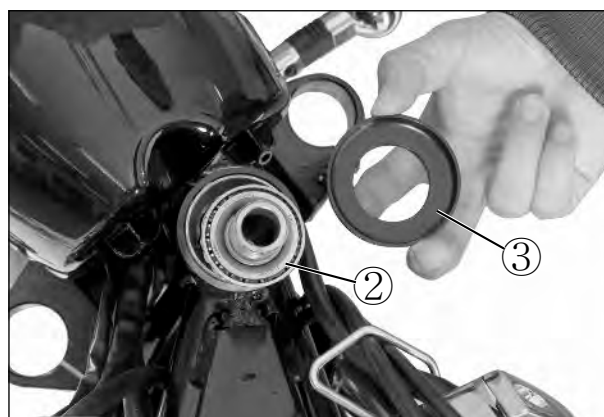

8-33 CHASSIS

- Install the handlebar holders and tighten their nuts temporarily.



- Install the steering stem.
- Tighten the steering stem nut ① and steering stem upper nut ② using the special tool.



Steering stem nut

: 80 ~ 100 N · m (8.0 ~ 10.0 kgf · m)

NOTE

The torque value of the steering stem nut and steering stem upper nut is reference data.



Clamp wrench : 09940-10122

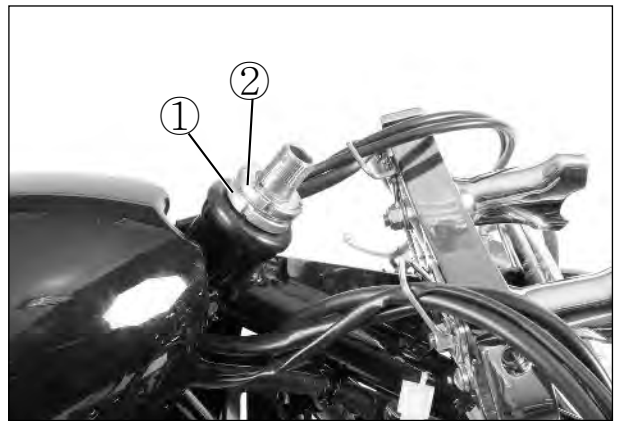

- Turn the steering stem lower bracket about five or six times to the right and left.
- Loosen the steering stem nut $\frac{1}{4}$ - $\frac{1}{2}$ of a turn (A).

NOTE

This adjustment will vary from motorcycle to motorcycle. Make sure that the steering turns smoothly and easily in both directions without play.

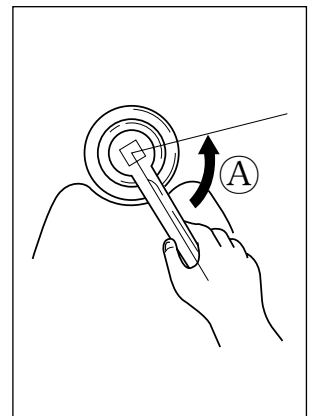
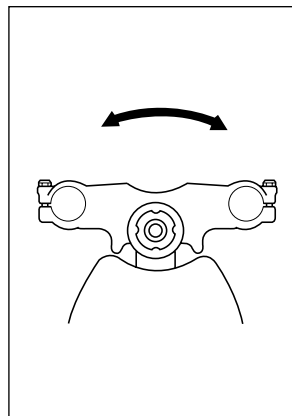

- Install the steering stem upper bracket ① and washer ②.
- Tighten the steering stem head nut ③ temporarily.

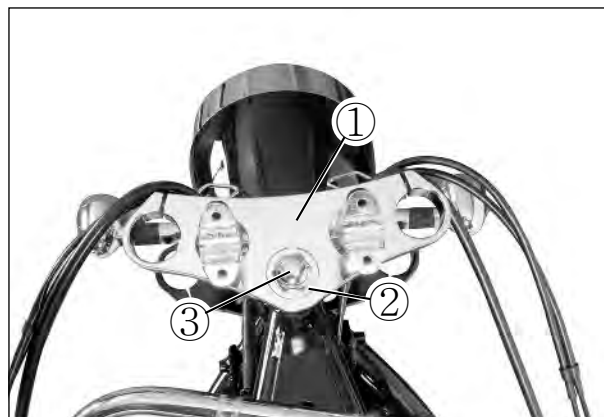

- Install the handlebars. (Refer to page 8-19)
- Tighten the handlebar holder nuts ④ to the specified torque.

**Handlebar holder nut**

: 40 ~ 60 N · m (4.0 ~ 6.0 kgf · m)

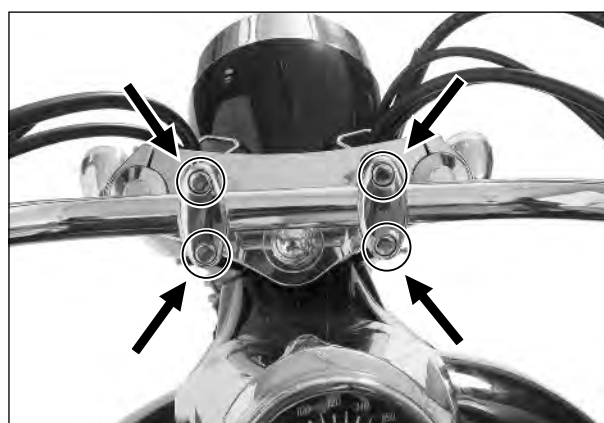
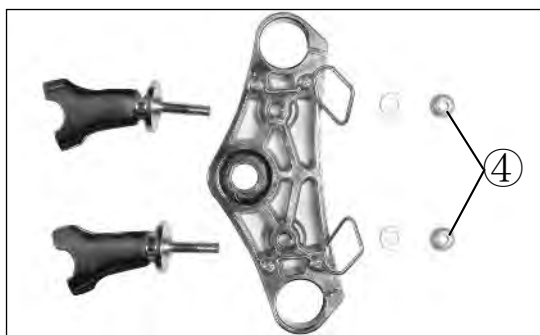

- Align the upper surface of the front fork inner tube with the upper surface of the steering stem upper bracket.
- Tighten the upper front fork clamp bolts ⑤ to the specified torque.

**Front fork upper clamp bolt**

: 22 ~ 35 N · m (2.2 ~ 3.5 kgf · m)

- Tighten the steering stem head nut ③ to the specified torque.

**Steering stem head nut**

: 80 ~ 100 N · m (8.0 ~ 10.0 kgf · m)



- Install the front turn signal lamp assembly.
- Install the front wheel. (Refer to page 8-9)

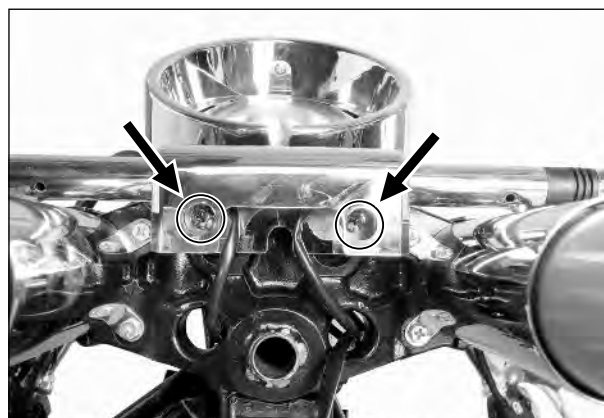

NOTE

Hold the front fork legs, move them back and forth and make sure that the steering is not loose.



REAR WHEEL

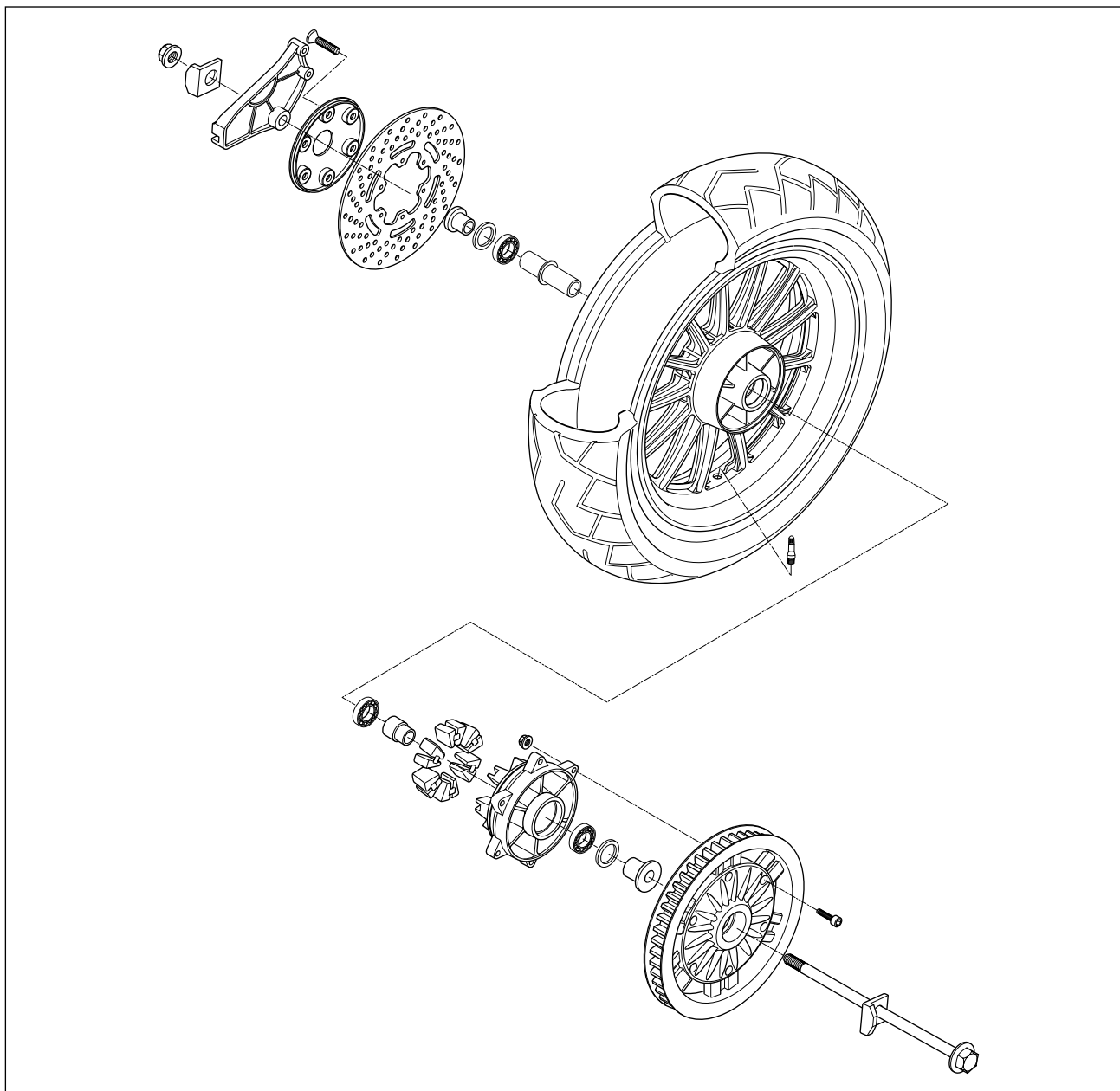

⦿ REMOVAL AND DISASSEMBLY

- Raise the rear wheel off the ground with a jack or block.
- After loosening the four mounting bolts, remove the engine pulley cover.

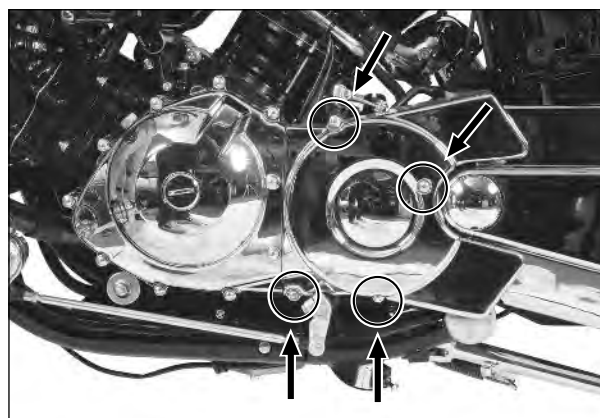

8-37 CHASSIS

- After loosening the four mounting bolts, remove the drive belt cover.

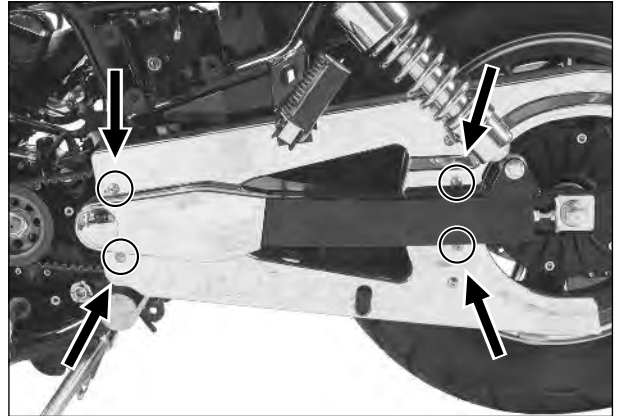

- Loosen the lock nuts ① and drive belt adjusters ②, right and left.
- Disengage the drive belt from the rear pulley.

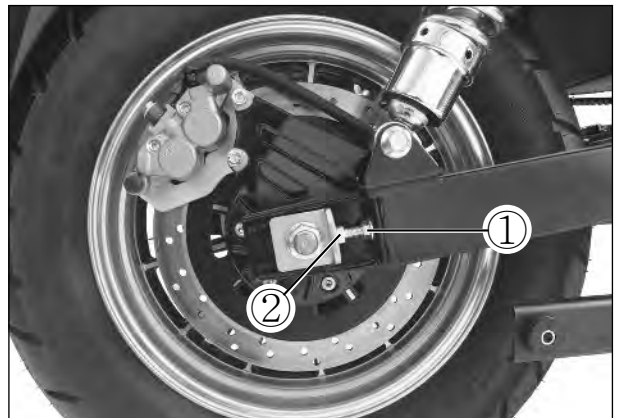

Right

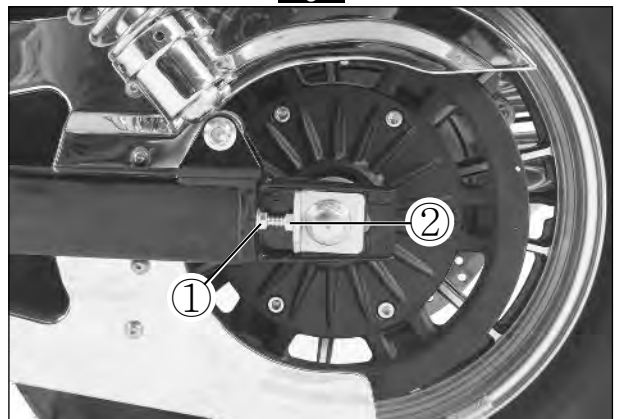

Left

- Remove the rear axle ③.
- Remove the rear wheel.

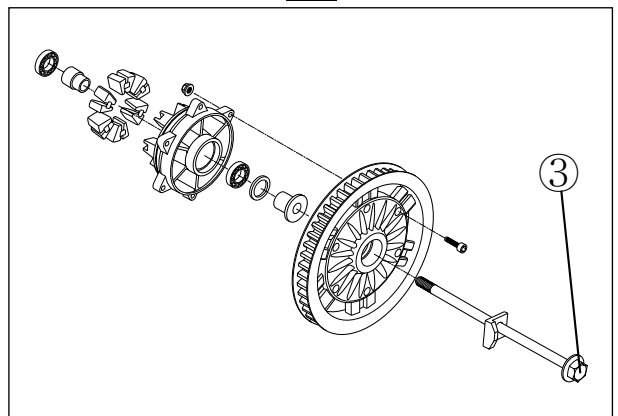

- After loosening the disk mounting bolts, remove the rear brake disk cover and brake disk.

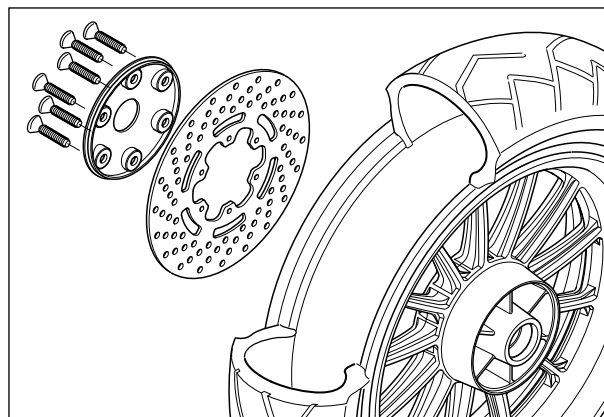

- Remove the spacer ①.
- Remove the rear pulley ② with the rear pulley mounting drum ③ from the rear wheel.

NOTE

Before separating the rear pulley and rear pulley mounting drum, slightly loosen the rear pulley bolts.

- Remove the rear wheel shock absorber ④.
- Remove the rear pulley ② from the rear pulley mounting drum.

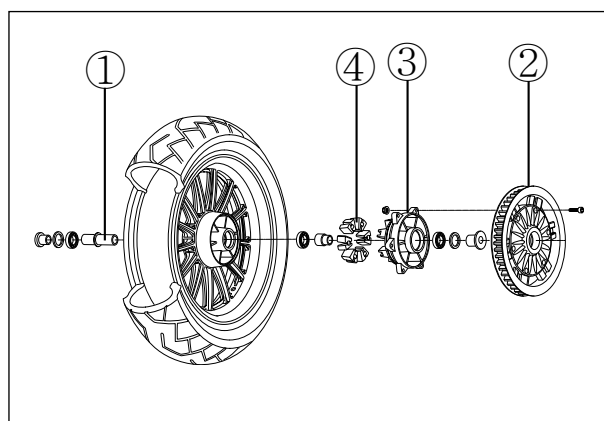

■ **WHEEL BEARING REMOVAL**

- Remove the bearing using the special tool.

 **Wheel bearing remover : 09941-50111**

 **CAUTION**

The removed bearing should be replaced with new one.

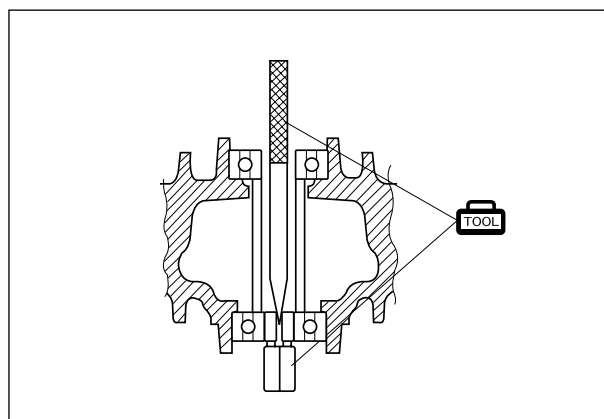

⊙ **INSPECTION**

WHEEL AXLE : Refer to page 8-8

WHEEL : Refer to page 8-8

WHEEL BEARING : Refer to page 8-8

TIRE : Refer to page 2-23

■ **REAR WHEEL SHOCK ABSORBER**

Inspect the rear wheel shock absorber for wear and damage.

Replace the rear wheel shock absorber if there is anything unusual.

■ **REAR PULLEY**

Inspect the pulley's teeth for wear. If they are worn, replace the pulley and drive belt as a set.

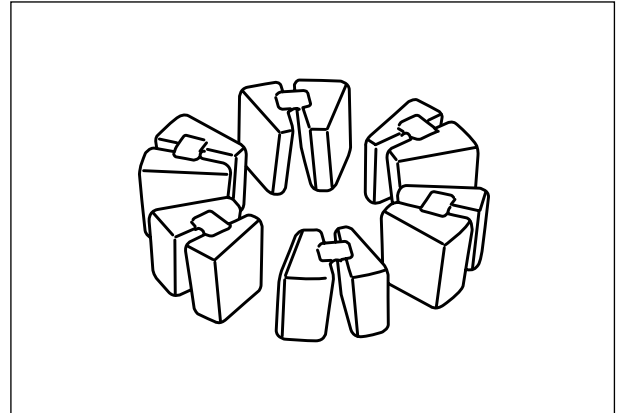

○ **REASSEMBLY AND REMOUNTING**

Reassemble and remount the rear wheel in the reverse order of removal and disassembly.

Pay attention to the following points :

- Tighten the rear pulley bolts to the specified torque.



Rear pulley bolt

: 20 ~ 30 N · m (2.0 ~ 3.0 kgf · m)

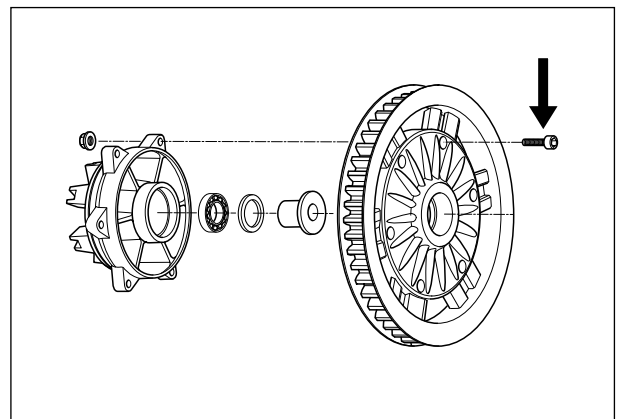

- With the rear wheel installed, tighten the rear axle ① to the specified torque.



Rear axle

: 90 ~ 140 N · m (9.0 ~ 14.0 kgf · m)

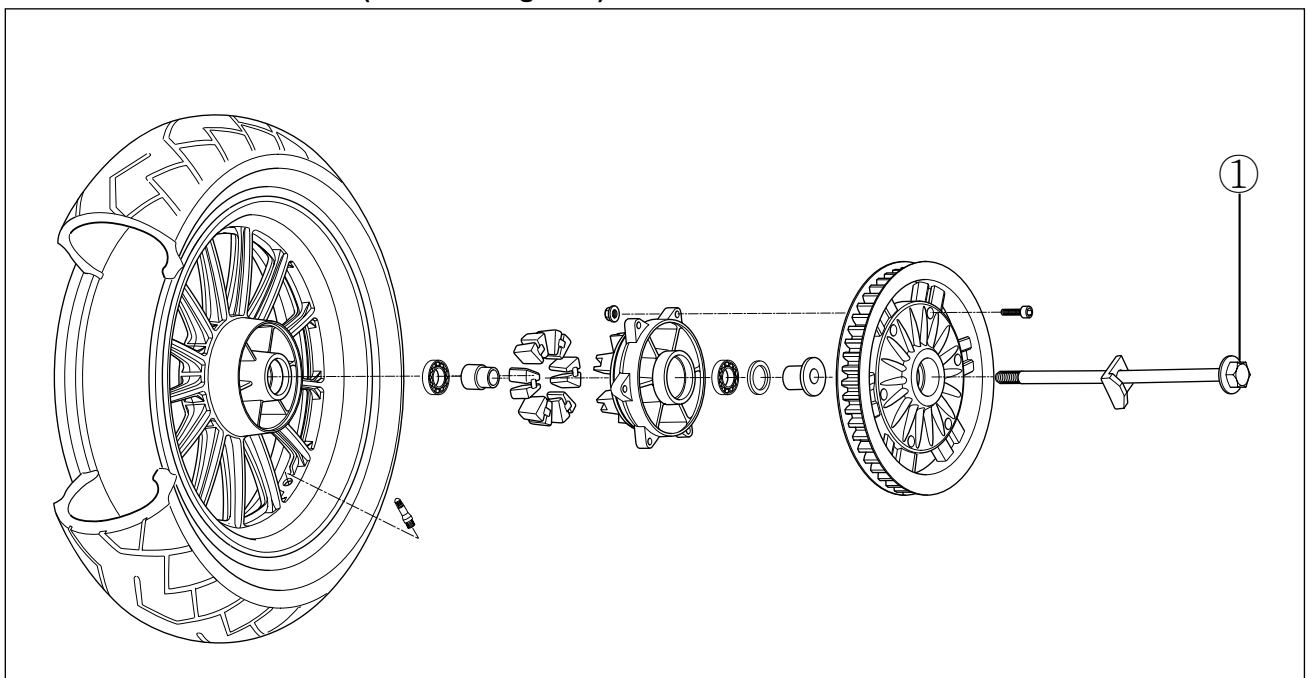

- After installing the drive belt to the rear pulley, adjust the drive belt by turning both belt adjusters ①.
- Tighten both belt adjuster lock nuts ② securely.

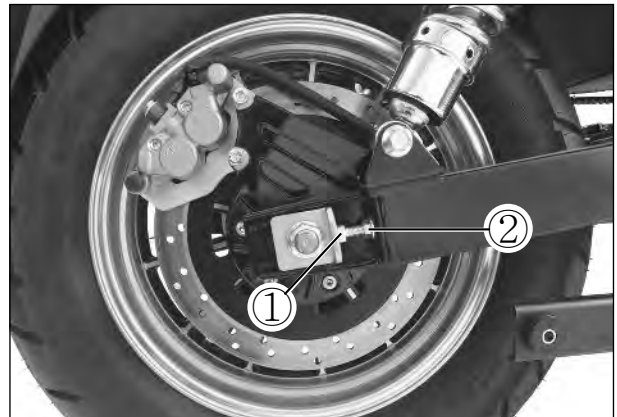

Right

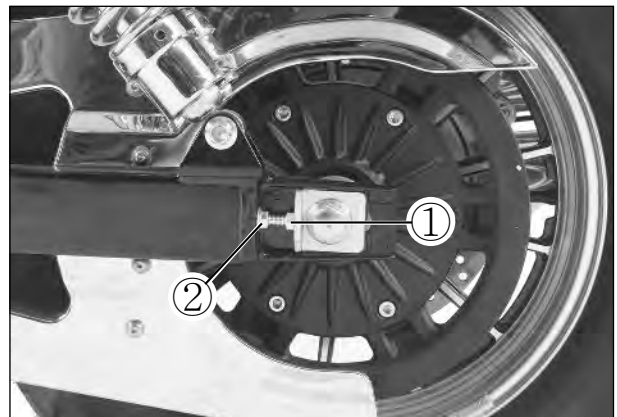

Left

REAR BRAKE

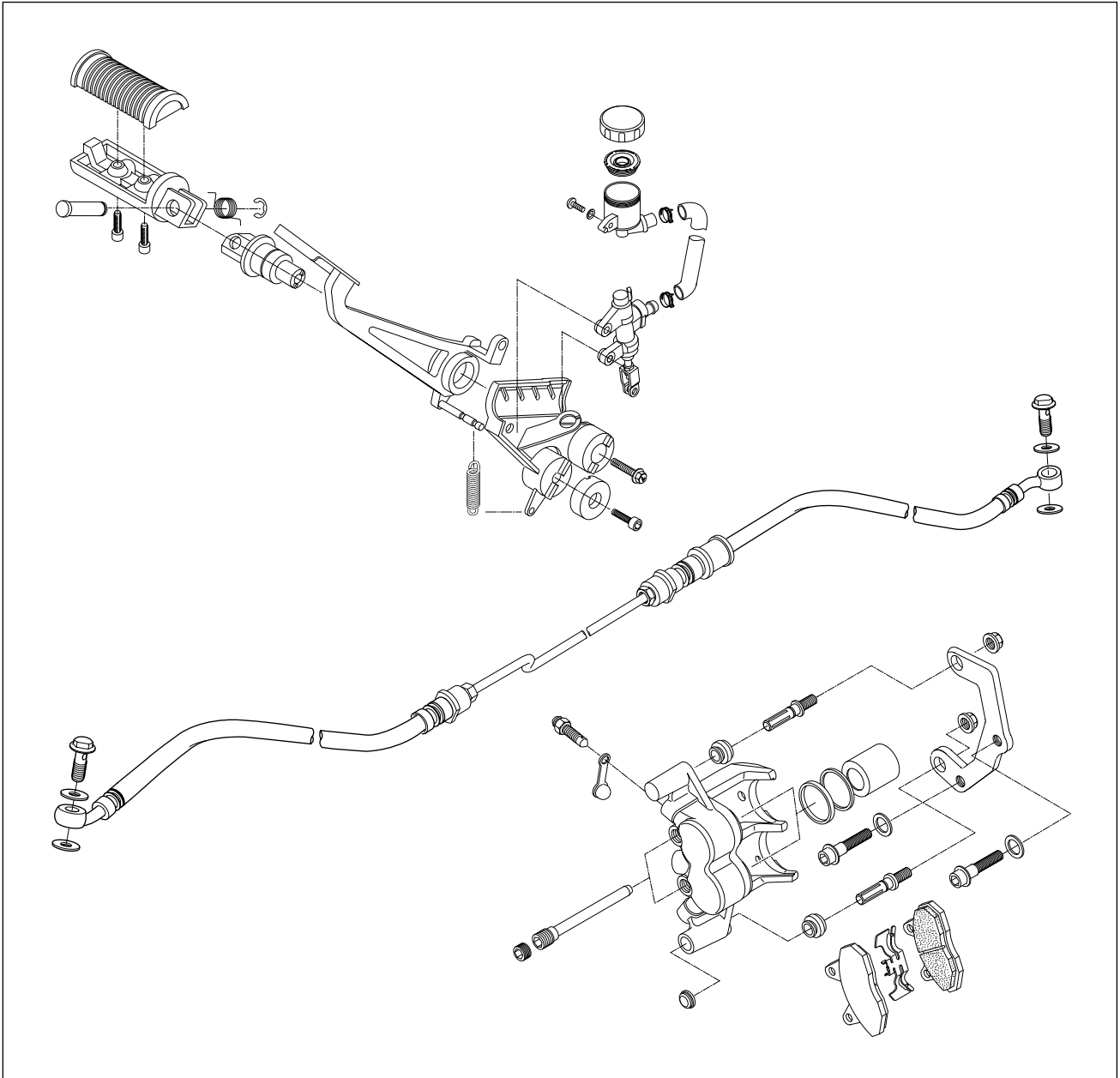

WARNING

- ❖ Do not mix brake fluid with different brand.
- ❖ Do not use a brake fluid kept in an open container or stored for a long period.
- ❖ To store brake fluid, make sure to seal the container and keep it in a safe place to be out of reach of children.
- ❖ When filling brake fluid, take care not to allow water or dirt to enter the system.
- ❖ To wash the brake system parts, use brake fluid and not any other material.
- ❖ Do not allow dirt and fluid to contact the brake disk or pad.

⚠ CAUTION

Do not allow brake fluid to contact the paint surface, plastic or rubber parts, or its chemical reaction can cause discoloration or crack.

● **BRAKE FLUID REPLACEMENT**

- For replacing procedure of brake fluid : Refer to page 2-19

● **BRAKE PAD REPLACEMENT**

- For replacing procedure of brake pad : Refer to page 2-18

● **CALIPER REMOVAL AND DISASSEMBLY**

- Drain brake fluid. (Refer to page 2-19)

⚠ CAUTION

To prevent brake fluid from splashing on the parts nearby, cover the parts with cloth.

- Remove the brake hose from the caliper by removing the caliper union bolt ① and catch the brake fluid in a suitable receptacle.

NOTE

Place a rag underneath the union bolt on the brake caliper to catch any spilt brake fluid.

- Remove the brake caliper by loosening the caliper mounting bolts ②.
- Remove the brake pad mounting bolt ③.
- Remove the brake pad. (Refer to page 2-18)
- Remove the brake pad spring.

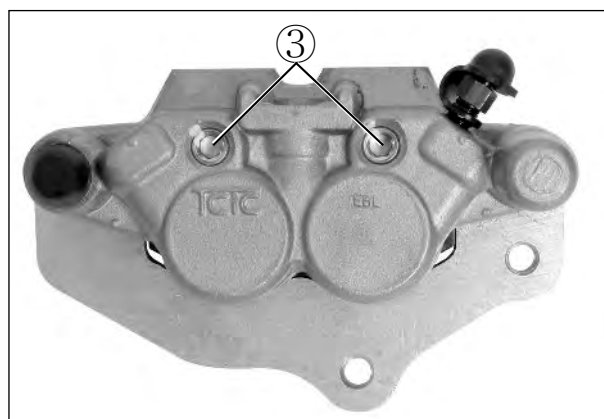
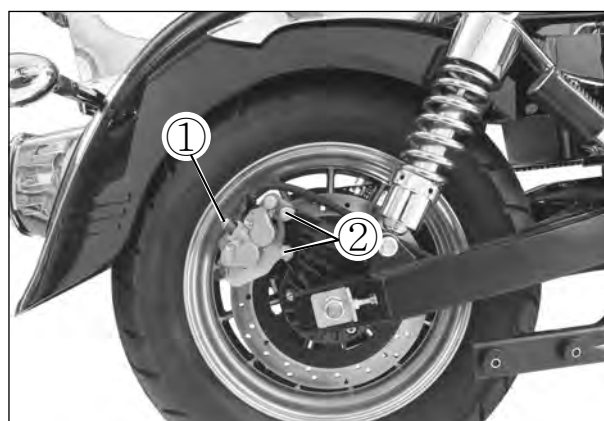

- Remove the brake caliper holder ①.

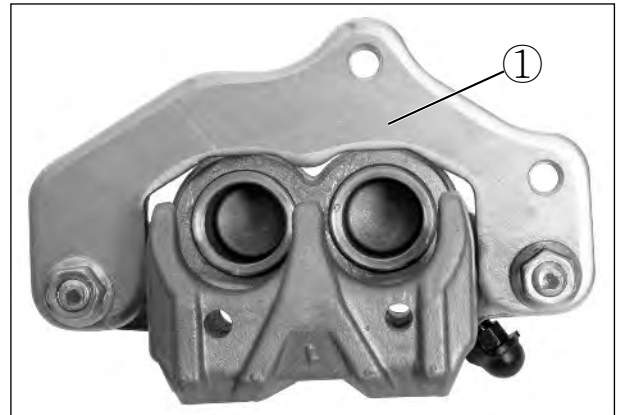

- Using compressed air, push out the caliper pistons.

⚠ WARNING

- ❖ Place a rag over the pistons to prevent it from popping out and flying and keeping hand off the piston.
- ❖ Be careful of brake fluid which can possibly splash.
- ❖ Do not use high pressure air but increase the spressure gradually.



- Remove the dust seal ② and piston seal ③.

⚠ CAUTION

- ❖ Care not to cause scratch on the cylinder bore.
- ❖ Do not reuse the piston seal and dust seal that have been removed.

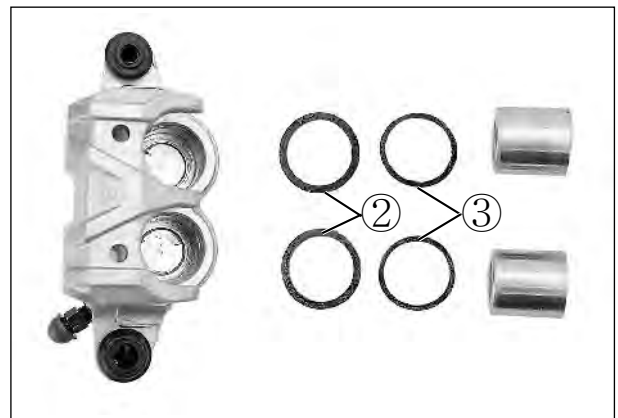

⊙ CALIPER INSPECTION

Inspect the caliper cylinder wall and piston surface for scratch, corrosion or other damages.

If any abnormal condition is noted, replace the caliper.



○ CALIPER REASSEMBLY AND REMOUNTING

Reassemble and remount the caliper in the reverse order of removal and disassembly procedures and observe the following points.

⚠ CAUTION

- ❖ Wash the caliper components with fresh brake fluid before reassembly. Do not wipe off brake fluid after washing the components.
- ❖ When washing the components, use the specified brake fluid. Never use different types of fluid or cleaning solvent such as gasoline, kerosine or the others.
- ❖ Replace the piston seal and dust seal into new ones with brake fluid applied.

 Brake fluid specification and classification : DOT 4

- Install the brake pad spring.
 - Apply **SILICONE GREASE** to the brake caliper holder.
-  **SILICONE GREASE**
- Install the brake pads. (Refer to page 2-18)

- Tighten the caliper mounting bolts ① and brake hose union bolt ② to the specified torque.

 **Rear brake caliper mounting bolts**
: 18 ~ 28 N · m (1.8 ~ 2.8 kgf · m)

Rear brake hose union bolts
: 20 ~ 25 N · m (2.0 ~ 2.5 kgf · m)

NOTE

Before remounting the caliper, push the piston all the way into the caliper.

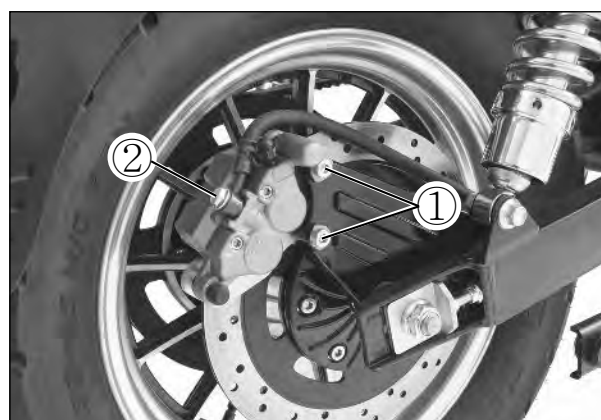
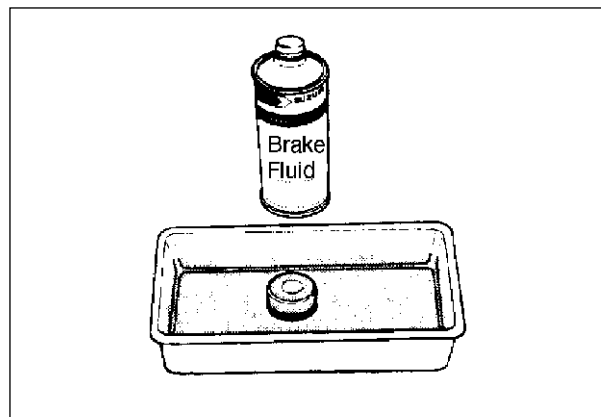

8-45 CHASSIS

- Fill the system with brake fluid and bleed air.
(Refer to page 2-19 ~ 20)
Inspection after reassembly : Refer to page 2-17

⊙ **BRAKE DISK INSPECTION** : Refer to page 8-15

REAR SHOCK ABSORBER

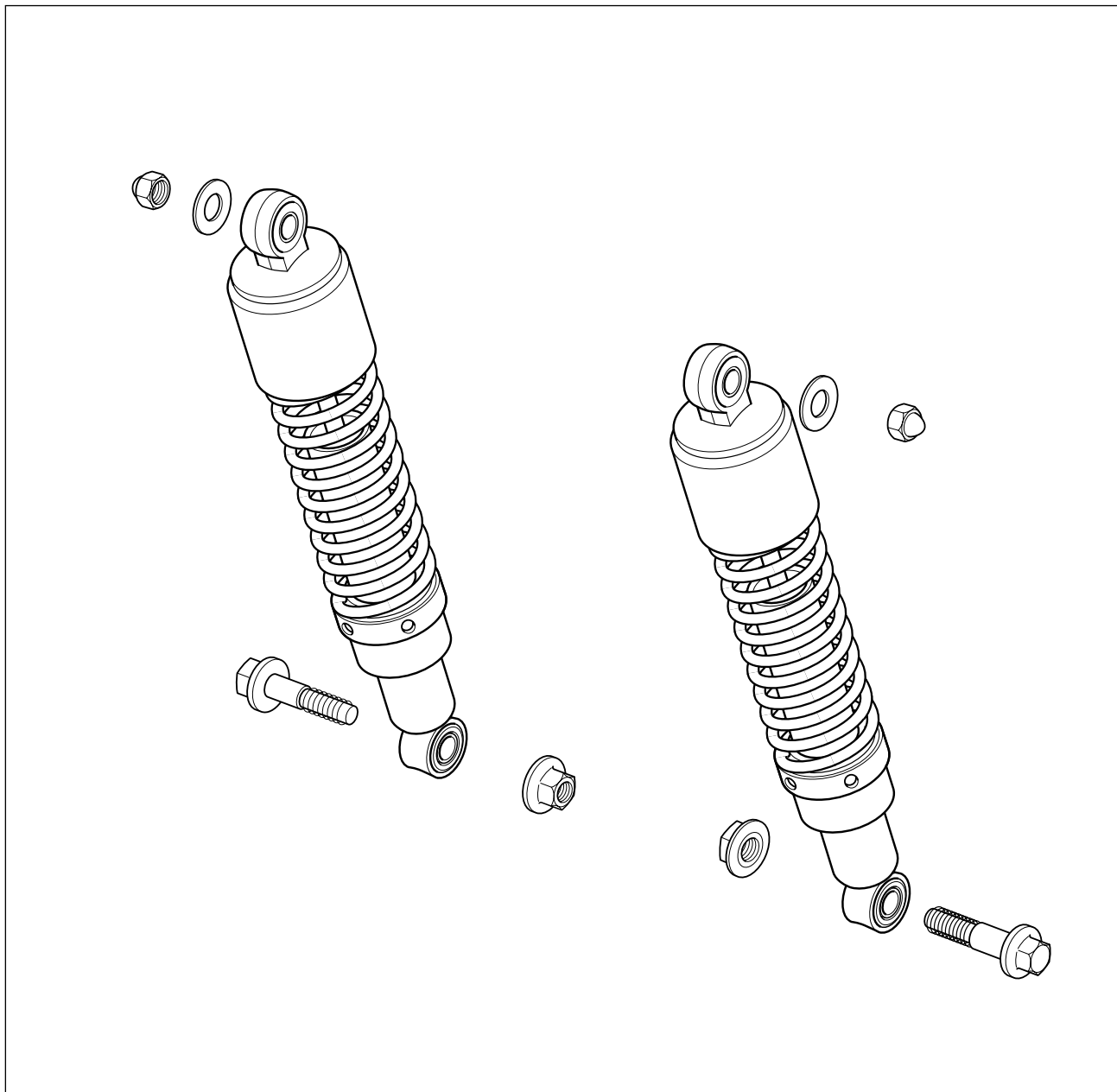

⦿ REMOVAL

- Remove the rear shock absorbers by removing their bolts and nuts.

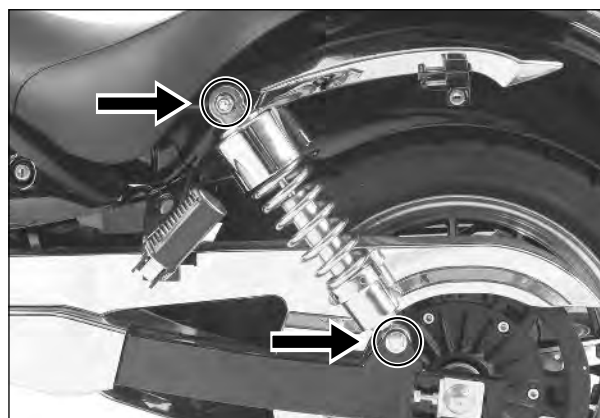

⦿ **INSPECTION**

Inspect the rear shock absorber for damage and oil leakage. If any defects are found, replace the rear shock absorber with a new one.

⚠ CAUTION

**Do not attempt to disassemble the rear shock absorber.
It is unserviceable.**

⦿ **REMountING**

Remount the rear shock absorber in the reverse order of removal.

Pay attention to the following points :

- Install the rear shock absorber and tighten the bolts and nuts to the specified torque.

🔩 Shock absorber mounting nut (upper)
: 20 ~ 30 N · m (2.0 ~ 3.0 kgf · m)

🔩 Shock absorber mounting bolt (lower)
: 35 ~ 55 N · m (3.5 ~ 5.5 kgf · m)

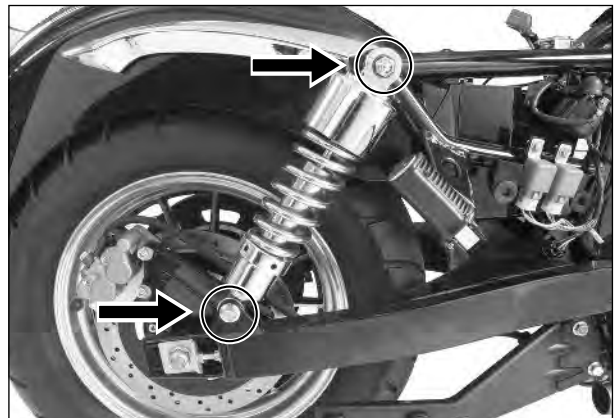
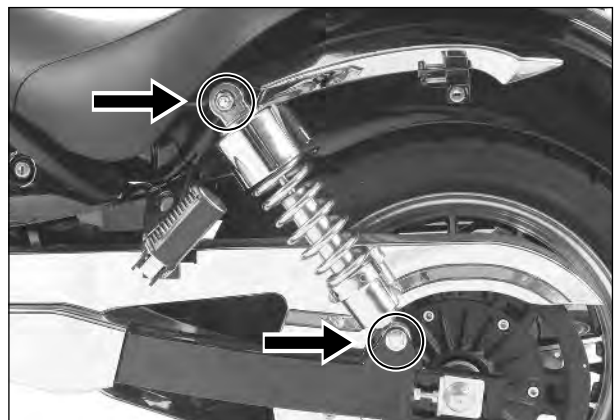
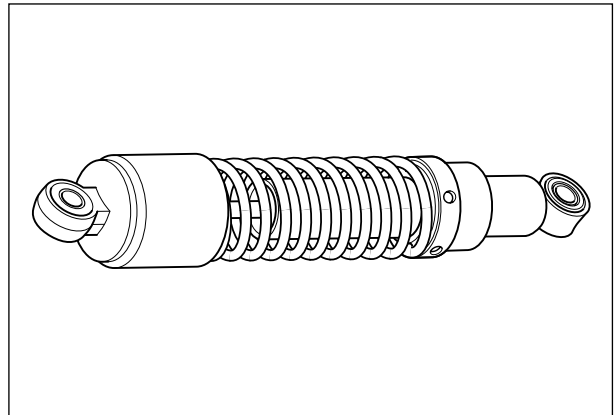

⦿ **SPRING PRE-LOAD ADJUSTMENT**

- Adjust the rear shock absorber spring pre-load.

Rear shock absorber spring free length	Service limit 200.0 mm (7.87 in)
Rear shock absorber spring pre-load	Standard 2/5 position

⚠ WARNING

**Unequal suspension adjustment can cause poor handling and loss of stability.
Adjust the right and left shock absorber to the same settings.**

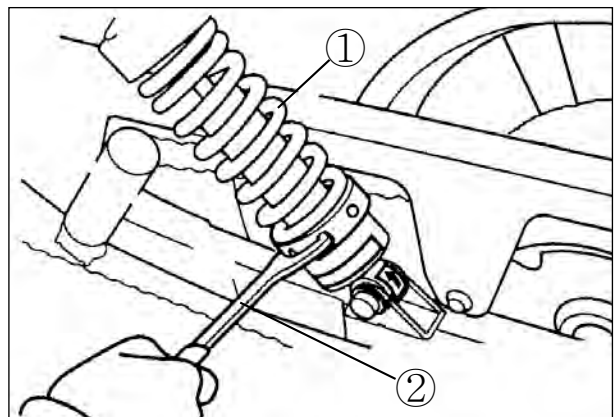

① Rear shock absorber ② Pin spanner

SWINGARM

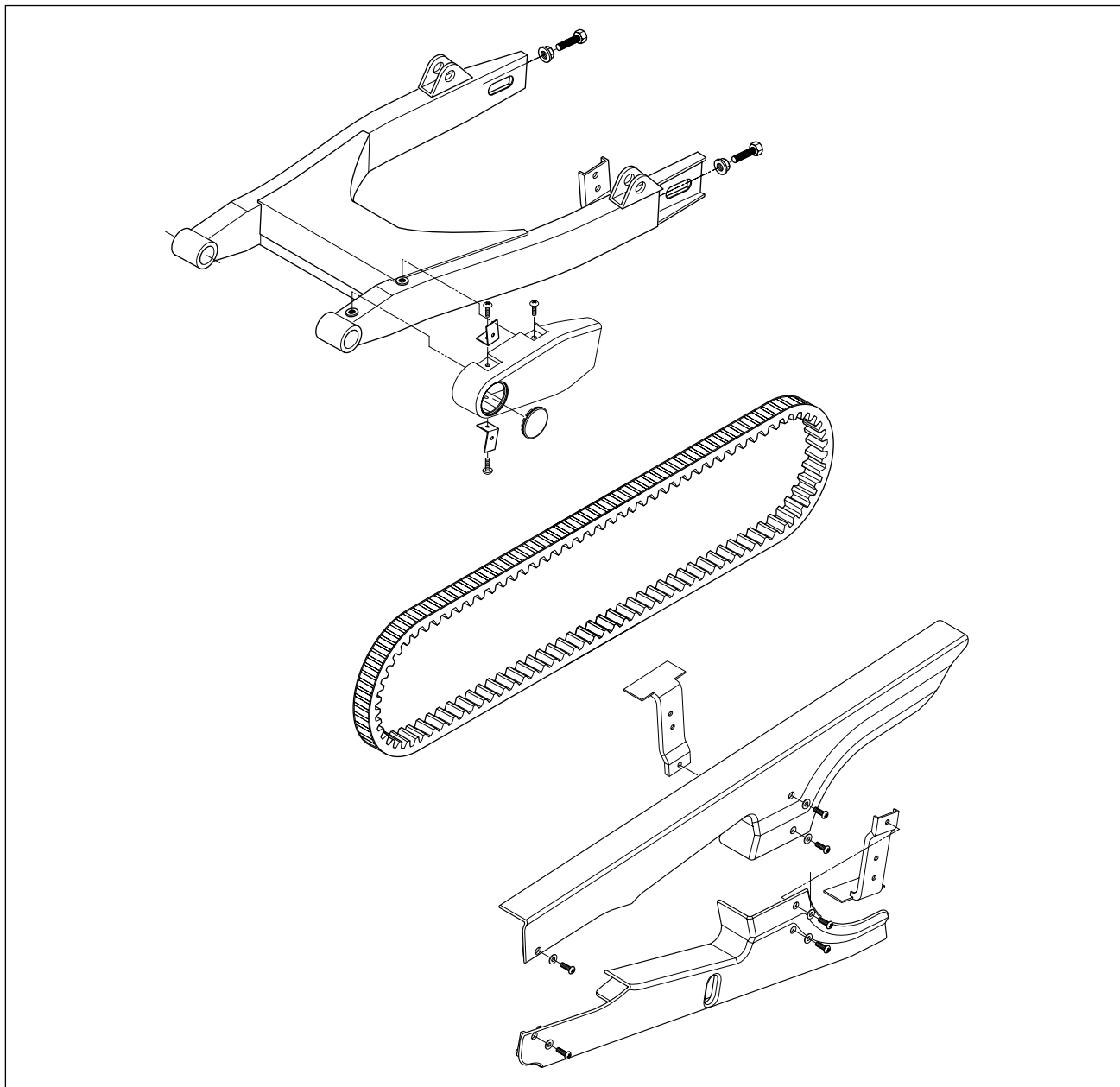

○ REMOVAL AND DISASSEMBLY

- Remove the rear wheel. (Refer to page 8-36)
- Remove the exhaust pipes and muffler. (Refer to page 3-5)

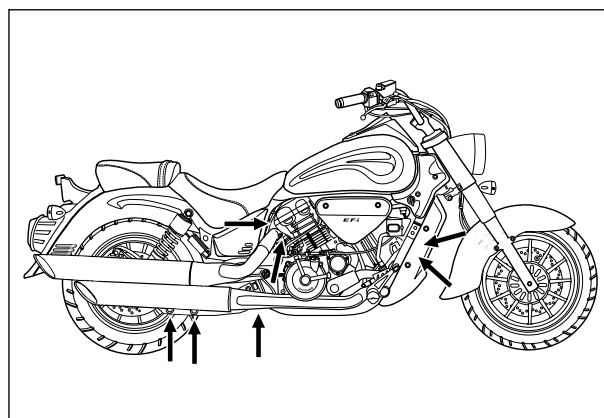

8-49 CHASSIS

- Remove the engine pulley cover ① and drive belt covers ②.

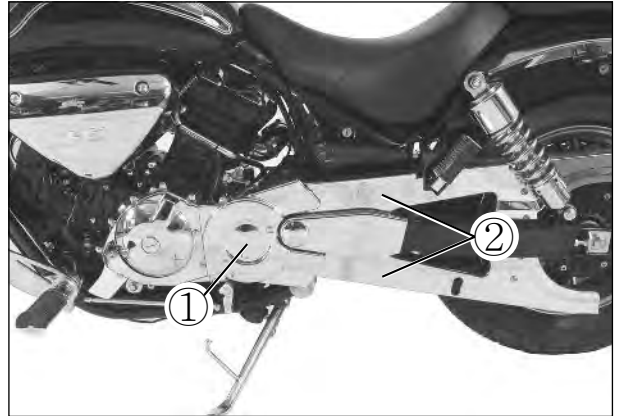

- After loosening the rear shock absorber lower bolts, disconnect the rear shock absorber from swingarm.

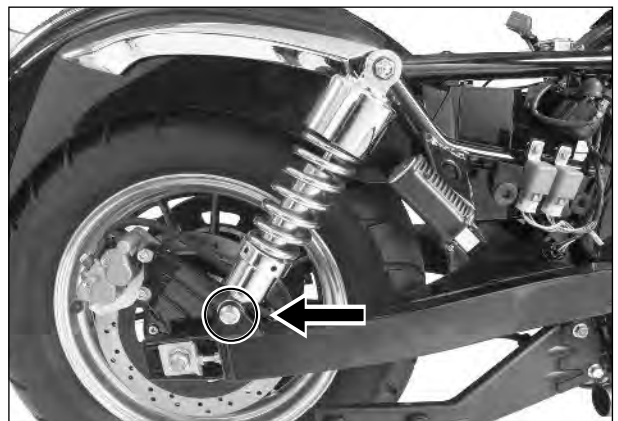
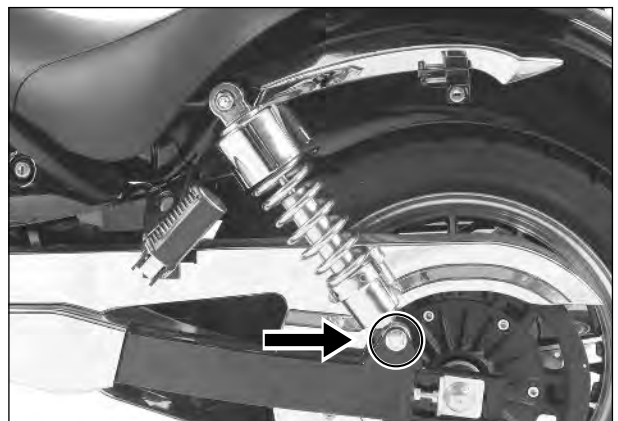

- Remove the swingarm mounting lock nut.
- Remove the swingarm pivot nut.
- Remove the swingarm by removing the pivot shaft.

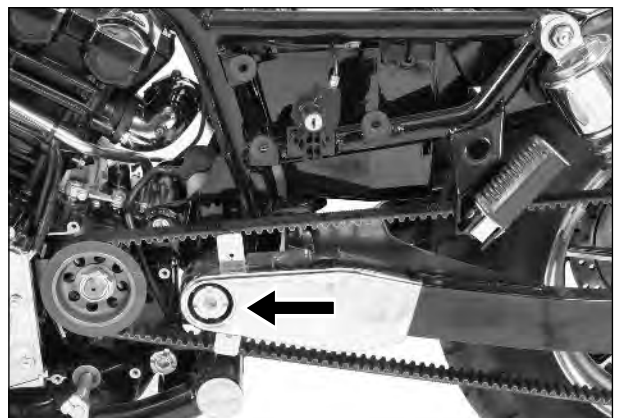

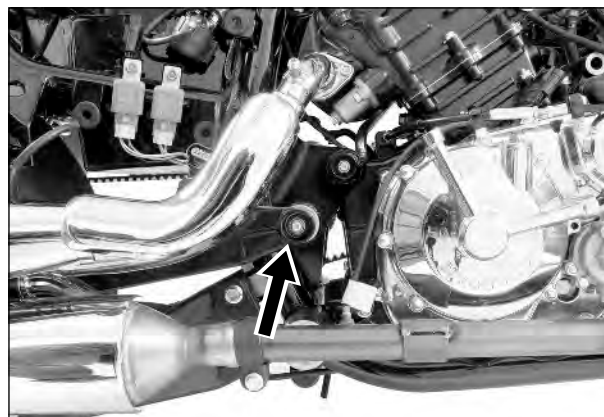

● INSPECTION

■ SWINGARM

Inspect the swingarm for damage.

If any defects are found, replace the swingarm with a new one.

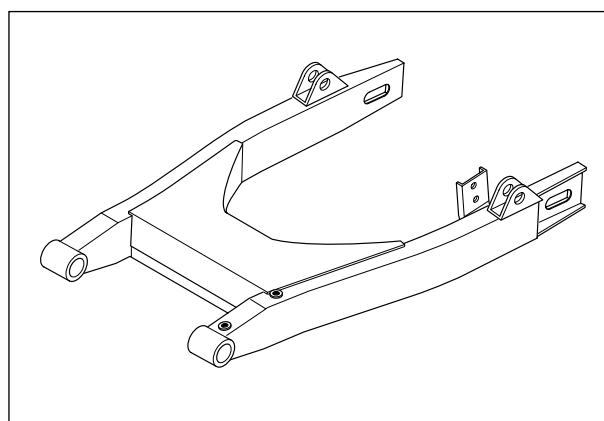

■ SWINGARM PIVOT SHAFT

Measure the pivot shaft runout using the dial gauge. If the pivot shaft exceeds the service limit, replace it with a new one.

Swingarm pivot shaft runout	Service limit
	0.6 mm (0.024 in)



Dial gauge : 09900-20606

Magnetic stand : 09900-20701

V-block : 09900-21304

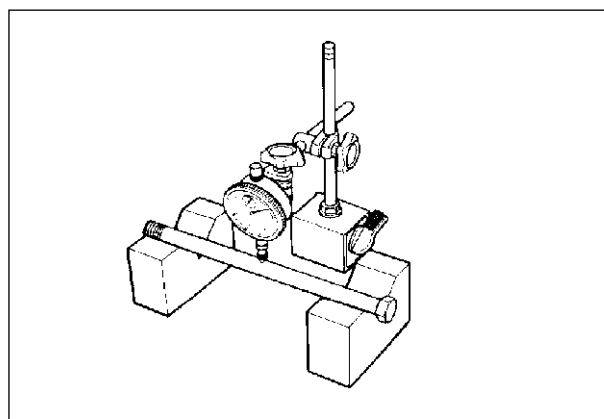

⊙ REASSEMBLY

Reassemble the swingarm and rear shock absorber in the reverse order of disassembly.

Pay attention to the following points :

- Install the swingarm and tighten the swingarm pivot shaft, nut and swingarm mounting lock nut with the special tool to the specified torque.

Swingarm pivot nut ①

: 50 ~ 70 N · m (5.0 ~ 7.0 kgf · m)

Swingarm pivot shaft ②

: 15 ~ 30 N · m (1.5 ~ 3.0 kgf · m)

Swingarm mounting lock nut (M26) ③

: 70 ~ 80 N · m (7.0 ~ 8.0 kgf · m)

Engine mounting socket wrench (M26)

: 09940H35010

- Install the rear wheel. (Refer to page 8-39)
- Adjust the following points :
Drive belt slack : Refer to page 2-15



CAUTION

Set the part ① of swingarm pivot shaft ② align center line by the hand temporarily and install the swingarm pivot shaft to the specified torque.
If otherwise, it is damage to the thread of swingarm pivot shaft.

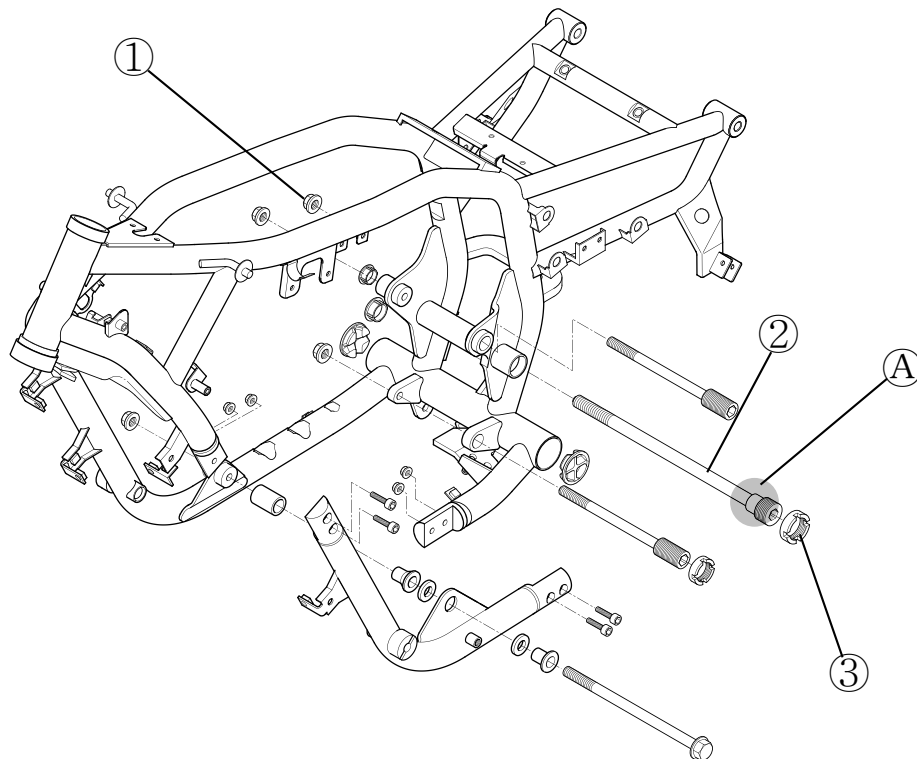

SERVICING INFORMATION

CONTENTS

TROUBLESHOOTING	9- 1
SPECIAL TOOLS	9-15
TIGHTENING TORQUE	9-18
SERVICE DATA	9-20
WIRE AND CABLE ROUTING	9-30
WIRING DIAGRAM	9-37

TROUBLESHOOTING

⊙ MALFUNCTION CODE AND DEFECTIVE CONDITION

MALFUNCTION CODE	DETECTED ITEM		DETECTED FAILURE CONDITION
			CHECK FOR
noEr	NO FAULT		—
0031	NO.1 O ₂ S heater Circuit	Low Voltage	After engine running, if oxygen sensor heater signal open or is happened the ground short fault for 1 second by 10 times in 12 times test cycle, the code 0031 is indicated.
			Oxygen sensor, lead wire / coupler connection.
0032		High Voltage	After engine running, if oxygen sensor heater signal is happened the high short fault for 1 second by 10 times in 12 times test cycle, the code 0032 is indicated.
			Oxygen sensor, lead wire / coupler connection.
0037	NO.2 O ₂ S heater Circuit	Low Voltage	After engine running, if oxygen sensor heater signal open or is happened the ground short fault for 1 second by 10 times in 12 times test cycle, the code 0037 is indicated.
			Oxygen sensor, lead wire / coupler connection.
0038		High Voltage	After engine running, if oxygen sensor heater signal is happened the high short fault for 1 second by 10 times in 12 times test cycle, the code 0038 is indicated.
			Oxygen sensor, lead wire / coupler connection.
0107	IAPS Circuit	Low Voltage or Open	The sensor should produce following voltage. 0.15 V ≤ Sensor output voltage Without the above range for 2.2 sec. and more, 0107 is indicated.
			Intake air pressure sensor, lead wire / coupler connection.
0108		High Voltage	The sensor should produce following voltage. Sensor output voltage ≤ 5 V Without the above range for 10.0 sec. and more, 0108 is indicated.
			Intake air pressure sensor, lead wire / coupler connection.
0112	IATS Circuit	Low Voltage	The sensor voltage should be the following. 0.1 V ≤ Sensor output voltage Without the above range for 6.25 sec. and more, 0112 is indicated.
			Intake air temperature sensor, lead wire / coupler connection.
0113		High Voltage or Open	The sensor voltage should be the following. Sensor output voltage ≤ 4.9 V Without the above range for 6.25 sec. and more, 0113 is indicated.
			Intake air temperature sensor, lead wire / coupler connection.

MALFUNCTION CODE	DETECTED ITEM		DETECTED FAILURE CONDITION
			CHECK FOR
0117	WTS Circuit	Low Voltage	The sensor voltage should be the following. $0.1\text{ V} \leq \text{Sensor output voltage}$ Without the above range for 6.25 sec. and more, 0117 is indicated.
			Water temperature sensor, lead wire / coupler connection.
0118	WTS Circuit	High Voltage or Open	The sensor voltage should be the following. $\text{Sensor output voltage} \leq 5\text{ V}$ Without the above range for 6.25 sec. and more, 0118 is indicated.
			Water temperature sensor, lead wire / coupler connection.
0122	TPS Circuit	Low Voltage or Open	The sensor should produce following voltage. $0.2\text{ V} \leq \text{Sensor output voltage}$ Without the above range for 7.8 sec. and more, 0122 is indicated.
			Throttle position sensor, lead wire / coupler connection.
0123	TPS Circuit	High Voltage	The sensor should produce following voltage. $\text{Sensor output voltage} \leq 4.9\text{ V}$ Without the above range for 7.8 sec. and more, 0123 is indicated.
			Throttle position sensor, lead wire / coupler connection.
0131	NO.1 O ₂ S Circuit	Low Voltage	After engine running, the oxygen sensor signal is inputted in ECU since then 300 sec. In this case, the sensor voltage should be the following. $30\text{ mV} \leq \text{Sensor output voltage}$ Without the above range for 28.1 sec. and more, 0131 is indicated.
			Oxygen sensor, lead wire / coupler connection.
0132	NO.1 O ₂ S Circuit	High Voltage	After engine running, the oxygen sensor signal is inputted in ECU since then 300 sec. In this case, the sensor voltage should be the following. $\text{Sensor output voltage} \leq 1.0\text{ V}$ Without the above range for 29.4 sec. and more, 0132 is indicated.
			Oxygen sensor, lead wire / coupler connection.
0137	NO.2 O ₂ S Circuit	Low Voltage	After engine running, the oxygen sensor signal is inputted in ECU since then 300 sec. In this case, the sensor voltage should be the following. $30\text{ mV} \leq \text{Sensor output voltage}$ Without the above range for 28.1 sec. and more, 0137 is indicated.
			Oxygen sensor, lead wire / coupler connection.
0138	NO.2 O ₂ S Circuit	High Voltage	After engine running, the oxygen sensor signal is inputted in ECU since then 300 sec. In this case, the sensor voltage should be the following. $\text{Sensor output voltage} \leq 1.0\text{ V}$ Without the above range for 29.4 sec. and more, 0138 is indicated.
			Oxygen sensor, lead wire / coupler connection.

9-3 SERVICING INFORMATION

MALFUNCTION CODE	DETECTED ITEM		DETECTED FAILURE CONDITION
			CHECK FOR
0201	NO.1 Fuel Injector Circuit Malfunction		After engine running, if NO.1 fuel injector signal open or is happened the high / ground short fault for 1 second by 5 times in 10 times test cycle, the code 0201 is indicated.
			Injector, wiring / coupler connection, power supply to the injector.
0202	NO.2 Fuel Injector Circuit Malfunction		After engine running, if NO.2 fuel injector signal open or is happened the high / ground short fault for 1second by 5 times in 10 times test cycle, the code 0202 is indicated.
			Injector, wiring / coupler connection, power supply to the injector.
0230	Fuel pump relay Circuit	Low Voltage or Open	After engine running, if fuel pump relay signal open or is happened the ground short fault for 1 second by 10 times in 20 times test cycle, the code 0230 is indicated.
			Fuel pump relay, connecting lead wire, power source to fuel pump relay, fuel injector.
0232		High Voltage	After engine running, if fuel pump relay signal is happened the high short fault for 1 second by 10 times in 20 times test cycle, the code 0232 is indicated.
			Fuel pump relay, connecting lead wire, power source to fuel pump relay, fuel injector.
0336	Pick-up coil	Noisy Signal	After engine running, if the magneto rotor tooth's error is happened continuously by 10 times in 100 times test cycle, the code 0336 is indicated.
			Pick-up coil wiring and mechanical parts. (Pick-up coil, lead wire coupler connection)
0337		No Signal	After engine running, if the pick-up coil signal does not reach ECU for more than 0.5 sec., the code 0337 is indicated.
			Pick-up coil wiring and mechanical parts. (Pick-up coil, lead wire coupler connection)
0351	NO.1 IG coil Malfunction		After engine running, if NO.1 ignition coil signal open or is happened the high / ground short fault for 1 second by 5 times in 10 times test cycle, the code 0351 is indicated.
			Ignition coil, wiring / coupler connection, power supply from the battery.
0352	NO.2 IG coil Malfunction		After engine running, if NO.2 ignition coil signal open or is happened the high / ground short fault for 1 second by 5 times in 10 times test cycle, the code 0352 is indicated.
			Ignition coil, wiring / coupler connection, power supply from the battery.

MALFUNCTION CODE	DETECTED ITEM		DETECTED FAILURE CONDITION
			CHECK FOR
0444	PV Circuit (California model only)	Open	After engine running, if purge control valve signal open or is happened the ground short fault for 1 second by 10 times in 12 times test cycle, the code 0444 is indicated.
			Purge control valve, wiring / coupler connection, power supply from the battery.
0445	PV Circuit (California model only)	Shorted	After engine running, if purge control valve signal is happened the high short fault for 1 second by 10 times in 12 times test cycle, the code 0445 is indicated.
			Purge control valve, wiring / coupler connection, power supply from the battery.
0505	ISC Error		After engine running, if idle speed is different to 500 rpm from the specified range in 25 seconds test cycle, the code 0505 is indicated.
			Idle speed control solenoid, wiring / coupler connection.
0562	Battery Voltage	Low	The battery voltage should be the following. $9\text{ V} \leq \text{Battery voltage}$ Without the above range for 3.125 sec. and more, 0562 is indicated.
			Battery, wiring / coupler connection to ECU.
0563	Battery Voltage	High	The battery voltage should be the following. $\text{Battery voltage} \leq 16\text{ V}$ Without the above range for 3.125 sec. and more, 0563 is indicated.
			Battery, wiring / coupler connection to ECU.
0650	"FI" check lamp Circuit Malfunction		After engine running, if "FI" check lamp signal open or is happened the high / ground short fault for 1 second by 40 times in 80 times test cycle, the code 0650 is indicated.
			"FI" check lamp, wiring / coupler connection.
0850	GP or Clutch lever Switch Circuit Malfunction		If gear position or clutch lever switch signal feedback is not active in continuous by 20 times in fully power down cycles, the code 0850 is indicated. (Fully power down cycle : Ignition switch "ON" → "OFF" position)
			Gear position or clutch lever switch, wiring / coupler connection, gearshift cam etc.

Complaint	Symptom and possible causes	Remedy
Engine idles poorly.	<ol style="list-style-type: none"> 1. Tappet clearance out of adjustment. 2. Poor seating of valves. 3. Defective valve guides. 4. Worn down camshafts. 5. Too wide spark plug gaps. 6. Defective ignition coils. 7. Defective pick-up coil. 8. Defective ECU. 9. Defective TP sensor. 10. Defective fuel pump. 11. Imbalanced throttle valve or SAV solenoid. 12. Damaged or cracked vacuum hose. 	<p>Adjust. Replace or repair. Replace. Replace. Adjust or replace. Replace. Replace. Replace. Replace. Replace. Adjust. Replace.</p>
Engine stalls often.	<p>Incorrect fuel / air mixture</p> <ol style="list-style-type: none"> 1. Defective IAP sensor or circuit. 2. Clogged fuel filter. 3. Defective fuel pump. 4. Defective fuel pressure regulator. 5. Defective WT sensor. 6. Defective thermostat. 7. Defective IAT sensor. 8. Damaged or cracked vacuum hose. <p>Fuel injector improperly operating</p> <ol style="list-style-type: none"> 1. Defective fuel injectors. 2. No injection signal from ECU. 3. Open or short circuited wiring connection. 4. Defective battery or low battery voltage. <p>Control circuit or sensor improperly operating</p> <ol style="list-style-type: none"> 1. Defective ECU. 2. Defective fuel pressure regulator. 3. Defective TP sensor. 4. Defective IAT sensor. 5. Defective pick-up coil. 6. Defective WT sensor. 7. Defective fuel pump relay. <p>Engine internal parts improperly operating</p> <ol style="list-style-type: none"> 1. Fouled spark plugs. 2. Defective pick-up coil or ECU. 3. Clogged fuel hose. 4. Tappet clearance out of adjustment. 	<p>Repair or replace. Clean or replace. Replace. Replace. Replace. Replace. Replace. Replace.</p> <p>Replace. Repair or replace. Repair or replace. Replace or recharge.</p> <p>Replace. Replace. Replace. Replace. Replace. Replace. Replace.</p> <p>Clean. Replace. Clean. Adjust.</p>

9-7 SERVICING INFORMATION

Complaint	Symptom and possible causes	Remedy
<p>Noisy engine.</p>	<p>Excessive valve chatter</p> <ol style="list-style-type: none"> 1. Too large tappet clearance. 2. Weakened or broken valve springs. 3. Worn tappet or cam surface. 4. Worn and burnt camshaft journal. <p>Noise seems to come from piston</p> <ol style="list-style-type: none"> 1. Worn down pistons or cylinders. 2. Combustion chambers fouled with carbon. 3. Worn piston pins or piston pin bore. 4. Worn piston rings or ring grooves. <p>Noise seems to come from cam chain</p> <ol style="list-style-type: none"> 1. Stretched chain. 2. Worn sprockets. 3. Tension adjuster not working. <p>Noise seems to come from clutch</p> <ol style="list-style-type: none"> 1. Worn splines of countershaft or hub. 2. Worn teeth of clutch plates. 3. Distorted clutch plates, driven and drive. 4. Worn clutch release bearing. 5. Weakened clutch dampers. <p>Noise seems to come from crankshaft</p> <ol style="list-style-type: none"> 1. Rattling bearings due to wear. 2. Worn and burnt big-end bearings. 3. Worn and burnt journal bearings. <p>Noise seems to come from transmission</p> <ol style="list-style-type: none"> 1. Worn or rubbing gears. 2. Worn splines. 3. Worn bearings. 4. Worn or rubbing primary gears. <p>Noise seems to come from water pump</p> <ol style="list-style-type: none"> 1. Too much play on pump shaft bearing. 2. Worn or damaged impeller shaft. 3. Worn or damaged mechanical seal. 4. Contact between pump case and impeller. 	<p>Adjust. Replace. Replace. Replace.</p> <p>Replace. Clean. Replace. Replace.</p> <p>Replace. Replace. Repair or replace.</p> <p>Replace. Replace. Replace. Replace. Replace the primary driven gear.</p> <p>Replace. Replace. Replace.</p> <p>Replace. Replace. Replace. Replace.</p> <p>Replace. Replace. Replace. Replace.</p>

9-9 SERVICING INFORMATION

Complaint	Symptom and possible causes	Remedy
<p>Engine lacks power.</p>	<p>Defective engine internal / electrical parts</p> <ol style="list-style-type: none"> 1. Loss of tappet clearance. 2. Weakened valve springs. 3. Valve timing out of adjustment. 4. Worn piston rings or cylinders. 5. Poor seating of valves. 6. Fouled spark plugs. 7. Incorrect spark plugs. 8. Clogged injectors. 9. Defective TP sensor. 10. Clogged air cleaner element. 11. Sucking air from throttle valve or vacuum hose. 12. Too much engine oil. 13. Defective fuel pump or ECU. 14. Defective pick-up coil and ignition coils. <p>Defective control circuit or sensor</p> <ol style="list-style-type: none"> 1. Low fuel pressure. 2. Defective TP sensor. 3. Defective IAT sensor. 4. Defective pick-up coil. 5. Defective IAP sensor. 6. Defective ECU. 7. Defective SAV solenoid. 8. Defective GP switch. 	<p>Adjust. Replace. Adjust. Replace. Repair. Clean or replace. Adjust or replace. Clean. Replace. Clean. Retighten or replace. Drain out excess oil. Replace. Replace.</p> <p>Repair or replace. Replace. Replace. Replace. Replace. Replace. Replace. Replace.</p>
<p>Engine overheats.</p>	<p>Defective engine internal parts</p> <ol style="list-style-type: none"> 1. Heavy carbon deposit on piston crowns. 2. Not enough oil in the engine. 3. Defective oil pump or clogged oil circuit. 4. Sucking air from intake pipes. 5. Use incorrect engine oil. 6. Defective cooling system. <p>Lean fuel / air mixture</p> <ol style="list-style-type: none"> 1. Short-circuited IAP sensor / lead wire. 2. Short-circuited IAT sensor / lead wire. 3. Sucking air from intake pipe joint. 4. Defective fuel injectors. 5. Defective WT sensor. 6. Defective cooling system. <p>The other factors</p> <ol style="list-style-type: none"> 1. Ignition timing too advanced due to defective timing advance system (WT sensor, pick-up coil, GP switch and ECU). 2. Drive belt / chain is too tight. 	<p>Clean. Add oil. Replace or clean. Retighten or replace. Change. See radiator section.</p> <p>Repair or replace. Repair or replace. Repair or replace. Replace. Replace. Consult radiator section.</p> <p>Replace. Adjust.</p>

Complaint	Symptom and possible causes	Remedy
Dirty or heavy exhaust smoke.	<ol style="list-style-type: none"> 1. Too much engine oil in the engine. 2. Worn piston rings or cylinders. 3. Worn valve guides. 4. Cylinder wall scored or scuffed. 5. Worn valves stems. 6. Defective stem seals. 7. Worn side rails. 	Check with inspection window, drain out excess oil. Replace. Replace. Replace. Replace. Replace. Replace.
Slipping clutch.	<ol style="list-style-type: none"> 1. Weakened clutch springs. 2. Worn or distorted pressure plates. 3. Distorted clutch plates or pressure plates. 	Replace. Replace. Replace.
Dragging clutch.	<ol style="list-style-type: none"> 1. Some clutch springs weakened while others are not. 2. Distorted pressure plates or clutch plates. 	Replace. Replace.
Transmission will not shift.	<ol style="list-style-type: none"> 1. Broken gearshift cam. 2. Distorted gearshift forks. 3. Worn gearshift pawl. 	Replace. Replace. Replace.
Transmission will not shift back.	<ol style="list-style-type: none"> 1. Broken return spring on shift shaft. 2. Rubbing or sticky shift shaft. 3. Distorted or worn gearshift forks. 	Replace. Repair or replace. Replace.
Transmission jumps out of gear.	<ol style="list-style-type: none"> 1. Worn shifting gears on driveshaft or countershaft. 2. Distorted or worn gearshift forks. 3. Weakened stopper spring on gearshift stopper. 	Replace. Replace. Replace.

⊙ RADIATOR (COOLING SYSTEM)

Complaint	Symptom and possible causes	Remedy
Engine overheats.	<ol style="list-style-type: none"> 1. Not enough engine coolant. 2. Radiator core clogged with dirt or scale. 3. Faulty cooling fan. 4. Defective cooling fan thermo-switch. 5. Clogged water passage. 6. Air trapped in the cooling circuit. 7. Defective water pump. 8. Use of incorrect engine coolant. 9. Defective thermostat. 	Add coolant. Clean. Repair or replace. Replace. Clean. Bleed out air. Replace. Replace. Replace.
Engine overcools.	<ol style="list-style-type: none"> 1. Defective cooling fan thermo-switch. 2. Extremely cold weather. 3. Defective thermostat. 	Replace. Put on the radiator cover. Replace.

⊙ ELECTRICAL

Complaint	Symptom and possible causes	Remedy
<p>No sparking or poor sparking.</p>	<ol style="list-style-type: none"> 1. Defective ignition coils or spark plug caps. 2. Defective spark plugs. 3. Defective pick-up coil. 4. Defective ECU. 5. Defective RO switch. 6. Open-circuited wiring connections. 	<p>Replace. Replace. Replace. Replace. Replace. Check and repair.</p>
<p>Spark plug soon become fouled with carbon.</p>	<ol style="list-style-type: none"> 1. Mixture too rich. 2. Idling speed set too high. 3. Incorrect gasoline. 4. Dirty element in air cleaner. 5. Spark plugs too cold. 	<p>Inspect EI system. Inspect EI system. Change. Clean or replace. Replace by hot type plug.</p>
<p>Spark plug become fouled too soon.</p>	<ol style="list-style-type: none"> 1. Worn piston rings. 2. Pistons or cylinders worn. 3. Excessive clearance of valve stems in valve guides. 4. Worn stem oil seal. 	<p>Replace. Replace. Replace. Replace.</p>
<p>Spark plug electrodes overheat or burn.</p>	<ol style="list-style-type: none"> 1. Spark plugs too hot. 2. The engine overheats. 3. Spark plugs loose. 4. Mixture too lean. 	<p>Replace by cold type plug. Tune up. Retighten. Inspect EI system.</p>
<p>Magneto charge, but charging rate is below the specification.</p>	<ol style="list-style-type: none"> 1. Lead wires tend to get shorted or open-circuited or loosely connected at terminals. 2. Grounded or open-circuited stator coils of magneto. 3. Defective regulator / rectifier. 4. Defective cell plates in the battery. 	<p>Repair or retighten. Replace. Replace. Replace the battery.</p>
<p>Magneto overcharges.</p>	<ol style="list-style-type: none"> 1. Internal short - circuit in the battery. 2. Resistor element in the regulator / rectifier damaged or defective. 3. Regulator / rectifier poorly grounded. 	<p>Replace the battery. Replace. Clean and tighten ground connection.</p>
<p>Magneto does not charge.</p>	<ol style="list-style-type: none"> 1. Open - or short - circuited lead wire, or loose lead connections. 2. Short - circuited, grounded or open stator coil. 3. Short - circuited or punctured regulator / rectifier. 	<p>Repair or replace or retighten. Replace. Replace.</p>
<p>Unstable charging.</p>	<ol style="list-style-type: none"> 1. Lead wire insulation frayed due to vibration resulting in intermittent shorting. 2. Magneto internally shorted. 3. Defective regulator / rectifier. 	<p>Repair or replace. Replace. Replace.</p>
<p>Starter switch is not effective.</p>	<ol style="list-style-type: none"> 1. Battery run down. 2. Defective switch contacts. 3. Brushes not seating properly on commutator in starter motor. 4. Defective starter relay / ignition interlock switch. 5. Defective main fuse. 	<p>Recharge or replace. Replace. Repair or replace. Replace. Replace.</p>

⊙ **BATTERY**

Complaint	Symptom and possible causes	Remedy
<p>“Sulfation” acidic white powdery substance or spots on surfaces of cell plates.</p>	<ol style="list-style-type: none"> 1. Not enough electrolyte. 2. Battery case is cracked. 3. Battery has been left in a run-down condition for a long time. 4. Contaminated electrolyte. (Foreign matter has entered the battery and become mixed with the electrolyte.) 	<p>Add distilled water, if the battery has not been damaged and “sulfation” has not advanced too far, and recharge. Replace the battery. Replace the battery or recharge. If “sulfation” has not advanced far, try to restore the battery by replacing the electrolyte, recharging it fully with the battery detached from the motorcycle and then adjusting electrolyte specific gravity.</p>
<p>Battery runs down quickly.</p>	<ol style="list-style-type: none"> 1. The charging method is not correct. 2. Cell plates have lost much of their active material as a result of over-charging. 3. A short-circuit condition exists within the battery due to excessive accumulation of sediments caused by the high electrolyte specific gravity. 4. Electrolyte specific gravity is too low. 5. Contaminated electrolyte. 6. Battery is too old. 	<p>Check the generator, regulator/rectifier and circuit connections, and make necessary adjustments to obtain specified charging operation. Replace the battery, and correct the charging system. Replace the battery. Recharge the battery fully and adjust electrolyte specific gravity. Replace the electrolyte, recharge the battery and then adjust specific gravity. Replace the battery.</p>
<p>Reversed battery polarity.</p>	<p>The battery has been connected the wrong way round in the system, so that it is being charged in the reverse direction.</p>	<p>Replace the battery and be sure to connect the battery properly.</p>
<p>Battery “sulfation”</p>	<ol style="list-style-type: none"> 1. Charging rate too low or too high. (When not in use, batteries should be recharged at least once a month to avoid sulfation.) 2. Battery electrolyte excessive or insufficient, or its specific gravity too high or too low. 3. The battery left unused for too long in cold climate. 	<p>Replace the battery. Keep the electrolyte up to the prescribed level, or adjust the specific gravity by consulting the battery maker’s directions. Replace the battery, if badly sulfated.</p>
<p>Battery discharges too rapidly.</p>	<ol style="list-style-type: none"> 1. Dirty container top and sides. 2. Impurities in the electrolyte or electrolyte specific gravity is too high. 	<p>Clean. Change the electrolyte by consulting the battery maker’s directions.</p>









⦿ CHASSIS









Complaint	Symptom and possible causes	Remedy
Steering feels too heavy or stiff.	<ol style="list-style-type: none"> 1. Steering stem nut overtightened. 2. Worn bearing or race in steering stem. 3. Distorted steering stem. 4. Not enough pressure in tires. 	Adjust. Replace. Replace. Adjust.
Steering oscillation.	<ol style="list-style-type: none"> 1. Loss of balance between right and left front suspensions. 2. Distorted front fork. 3. Distorted front axle or crooked tire. 4. Loose steering stem nut. 5. Worn or incorrect tire or wrong tire pressure. 6. Worn bearing/race in steering stem. 	Replace. Repair or replace. Replace. Adjust. Adjust or replace. Replace.
Wobbling front wheel.	<ol style="list-style-type: none"> 1. Distorted wheel rim. 2. Worn-down wheel bearings. 3. Defective or incorrect tire. 4. Loosen nut on axle. 5. Incorrect front fork oil level. 6. Incorrect front wheel weight balance. 	Replace. Replace. Replace. Retighten. Adjust. Adjust.
Front suspension too soft.	<ol style="list-style-type: none"> 1. Weakened springs. 2. Not enough fork oil. 3. Wrong viscous fork oil. 4. Improperly set front fork damping force adjuster. 	Replace. Refill. Replace. Adjust.
Front suspension too stiff.	<ol style="list-style-type: none"> 1. Fork oil too viscous. 2. Too much fork oil. 3. Bent front axle. 4. Improperly set front fork damping force adjuster. 	Replace. Drain excess oil. Replace. Adjust.
Noisy front suspension.	<ol style="list-style-type: none"> 1. Not enough fork oil. 2. Loosen nuts on suspension. 	Refill. Retighten.
Wobbling rear wheel.	<ol style="list-style-type: none"> 1. Distorted wheel rim. 2. Worn-down rear wheel bearing. 3. Defective or incorrect tire. 4. Loose nut on axle. 5. Worn swingarm bushing or bearing. 6. Loosen nut on the rear shock. 	Replace. Replace. Replace. Retighten. Replace. Retighten.
Rear suspension too soft.	<ol style="list-style-type: none"> 1. Weakened springs. 2. Rear suspension adjuster improperly set. 	Replace. Adjust.
Rear suspension too stiff.	<ol style="list-style-type: none"> 1. Rear suspension adjuster improperly set. 2. Worn swingarm bushing or bearing. 	Adjust. Replace.
Noisy rear suspension.	<ol style="list-style-type: none"> 1. Loosen nuts on suspension. 2. Worn swingarm bushing or bearing. 	Retighten. Replace.

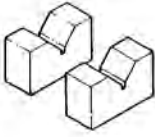

⊙ BRAKES





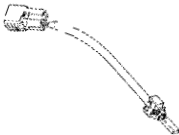



Complaint	Symptom and possible causes	Remedy
Poor braking (FRONT and REAR)	<ol style="list-style-type: none"> 1. Not enough brake fluid in the reservoir. 2. Air trapped in brake fluid circuit. 3. Pads worn down. 4. Too much play on brake lever or pedal. 5. Oil adhesion on friction surface of pads. 6. Worn disk. 	Refill to level mark. Bleed air out. Replace. Adjust. Clean disk and pads. Replace.
Insufficient brake power.	<ol style="list-style-type: none"> 1. Leakage of brake fluid from hydraulic system. 2. Worn pads. 3. Oil adhesion of engaging surface of pads. 4. Worn disk. 5. Air in hydraulic system. 	Repair or replace. Replace. Clean disk and pads. Replace. Bleed air.
Brake squeaking.	<ol style="list-style-type: none"> 1. Carbon adhesion on pad surface. 2. Tilted pad. 3. Damaged wheel bearing. 4. Loosen front-wheel axle or rear-wheel axle. 5. Worn pads. 6. Foreign material in brake fluid. 7. Clogged return port of master cylinder. 	Repair surface with sandpaper. Modify pad fitting. Replace. Tighten to specified torque. Replace. Replace brake fluid. Disassemble and clean master cylinder.
Excessive brake lever stroke.	<ol style="list-style-type: none"> 1. Air in hydraulic system. 2. Insufficient brake fluid. 3. Improper quality of brake fluid. 	Bleed air. Replenish fluid to specified level ; bleed air. Replace with correct fluid.
Leakage of brake fluid.	<ol style="list-style-type: none"> 1. Insufficient tightening of connection joints. 2. Cracked hose. 3. Worn piston and/or cup. 	Tighten to specified torque. Replace. Replace piston and/or cup.

SPECIAL TOOLS







Special tools	Part Number · Part Name · Description
	09900-20101 Vernier Caliper Used to conveniently measure various dimensions.
	09900-20201 Micrometer (0~25mm) Used for precise measurement (00~25mm measure ranges).
	09900-20202 Micrometer (25~50mm) Used for precise measurement (25~50mm measure ranges).
	09900-20203 Micrometer (50~75mm) Used for precise measurement (50~75mm measure ranges).
	09900-20204 Micrometer (75~100mm) Used for precise measurement (75~100mm measure ranges).
	09900-20508 Cylinder gauge set Measure inside diameter of cylinder.
	09900-20605 Dial calipers Measure width of conrod big-end.
	09900-20606 Dial gauge Measure oscillation of wheel with using magnetic stand.
	09900-20701 Magnetic stand With using dial gauge.

Special tools	Part Number · Part Name · Description
	09900-20806 Thickness gauge Measure clearance of piston ring.
	09900-21109 Torque wrench Measure torque of tightening.
	09900-21304 V-block With using magnetic stand.
	09900-22301 Plastigauge Measure clearance of crankshaft thrust.
	09900-22401 Small bore gauge Measure inside diameter of conrod small-end.
	09900-25002 Pocket tester Measure voltage, electric current, resistance.
	09900-25008 Multi circuit tester set Inspect thermo-switch or temperature sensor.
	09900-26006 Engine tachometer Measure rotational frequency of engine.
	09900-27000 Mode select switch Inspect EI system sensor.

Special tools	Part Number · Part Name · Description
	09910-20115 Conrod holder
	Used to lock the crankshaft.
	09910-32812 Crankshaft installer
	Used to install the crankshaft in the crankcase.
	09910-32813 Crankshaft installer adapter
	Used to with the crankshaft installer.
	09910-34510 Piston pin puller
	Use to remove the piston pin.
	09913-50121 Oil seal remover
	Used to remove the oil seal.
	09913-70122 Bearing installer
	Used to drive bearing in.
	09913-75820 Bearing installer
	Used to drive bearing in.
	09913-76010 Bearing installer
	Used to drive bearing in.
	09913-80112 Bearing installer
	Used to drive bearing in.

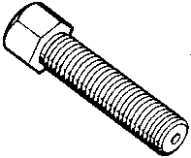
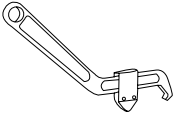
Special tools	Part Number · Part Name · Description
	09915-54510 Fuel pump pressure gauge
	Measure fuel pressure of fuel pump.
	09915-64511 Compression gauge
	Measure cylinder compression.
	09915-74511 Oil pressure gauge
	Measure oil pressure of 4-stroke engine.
	09916-14510 Valve spring compressor
	Used to remove and remounting valve stem.
	09916-14520 Valve spring compressor attachment
	Used with valve spring compressor.
	09920-13120 Crankcase separator
	Separate to crankcase.
	09920-53710 Clutch sleeve hub holder
	Used to install or remove clutch sleeve hub nut.
	09921-20200 Bearing remover (10mm)
	Used to remove bearing with the rotor remove sliding shaft.
	09921-20210 Bearing remover (12mm)
	Used to remove bearing with the rotor remove sliding shaft.

9-17 SERVICING INFORMATION

Special tools	Part Number · Part Name · Description
	09923-73210 Bearing remover (17mm)
	Used to remove bearing with the rotor remove sliding shaft.
	09923-74510 Bearing remover (20~35mm)
	Used to remove bearing with the rotor remove sliding shaft.
	09930-30102 Rotor remove sliding shaft
	Used to with bearing remover.
	09930-30165 Rotor remover
	Used to remove rotor.
	09940-10122 Clamp wrench
	A hook wrench to adjust the steering head of motorcycle.
	09940H30010 Engine mounting socket wrench (M20)
	Used to install or remove engine mounting lock nut.
	09940H35010 Engine mounting socket wrench (M26)
	Used to install or remove swingarm mounting lock nut.
	09941-34513 Steering race installer
	Used to install steering outer race.
	09941-50111 Wheel bearing remover
	Used to remove wheel bearing.

Special tools	Part Number · Part Name · Description
	09943-74111 Front fork oil level gauge
	Used to drain the fork oil to the specified level.

TIGHTENING TORQUE

⊙ ENGINE

ITEM		N · m	kgf · m
Coolant drain bolt		11 ~ 14	1.1 ~ 1.4
Cooling fan mounting bolt		8 ~ 12	0.8 ~ 1.2
Cooling fan motor mounting bolt		8	0.8
Cooling fan thermo-switch		13	1.3
Radiator mounting bolt		8 ~ 12	0.8 ~ 1.2
Magneto rotor bolt		110 ~ 170	11.0 ~ 17.0
Magneto cover bolt		10	1.0
Muffler connecting bolt		20 ~ 25	2.0 ~ 2.5
Muffler mounting bolt		20 ~ 25	2.0 ~ 2.5
Exhaust pipe bolt		18 ~ 28	1.8 ~ 2.8
Thermostat case bolt		10	1.0
Starter clutch bolt		23 ~ 28	2.3 ~ 2.8
Cylinder head bolt	M 6	8 ~ 12	0.8 ~ 1.2
	M 10	40 ~ 45	4.0 ~ 4.5
Cylinder head cover bolt		12 ~ 16	1.2 ~ 1.6
Cylinder head base bolt		8 ~ 12	0.8 ~ 1.2
Cylinder base nut		7 ~ 11	0.7 ~ 1.1
Engine pulley nut		130 ~ 160	13.0 ~ 16.0
Engine oil check plug		18	1.8
Engine oil drain plug		21	2.1
Engine mounting nut		45 ~ 70	4.5 ~ 7.0
Engine mounting lock nut	M 20	35 ~ 50	3.5 ~ 5.0
Engine mounting bolt		15 ~ 30	1.5 ~ 3.0
Spark plug		11	1.1
Cam chain tensioner bolt		8 ~ 12	0.8 ~ 1.2
Cam chain tensioner adjuster bolt		8 ~ 12	0.8 ~ 1.2
Crankcase bolt	M 6	11	1.1
	M 8	26	2.6
Clutch sleeve hub nut		40 ~ 60	4.0 ~ 6.0
Primary drive gear nut		40 ~ 60	4.0 ~ 6.0
Camshaft housing bolt		12	1.2
Horn mounting bolt		8 ~ 12	0.8 ~ 1.2

⊙ CHASSIS

ITEM		N · m	kgf · m
Rear shock absorber mounting nut (Upper)		20 ~ 30	2.0 ~ 3.0
Rear shock absorber mounting bolt (Lower)		35 ~ 55	3.5 ~ 5.5
Rear pulley bolt		20 ~ 30	2.0 ~ 3.0
Rear axle bolt		90 ~ 140	9.0 ~ 14.0
Swingarm pivot nut		50 ~ 70	5.0 ~ 7.0
Swingarm pivot shaft		15 ~ 30	1.5 ~ 3.0
Swingarm mounting lock nut	M26	70 ~ 80	7.0 ~ 8.0
Steering stem nut		80 ~ 100	8.0 ~ 10.0
Steering stem head nut		80 ~ 100	8.0 ~ 10.0
Front and Rear brake disk bolt		18 ~ 28	1.8 ~ 2.8
Front brake master cylinder mounting bolt		5 ~ 8	0.5 ~ 0.8
Rear brake master cylinder mounting bolt		18 ~ 28	1.8 ~ 2.8
Front and Rear brake caliper air bleeder valve		6 ~ 8	0.6 ~ 0.8
Front and Rear brake caliper mounting bolt		18 ~ 28	1.8 ~ 2.8
Front and Rear brake hose union bolt		20 ~ 25	2.0 ~ 2.5
Front brake caliper housing bolt		40 ~ 45	4.0 ~ 4.5
Front axle		50 ~ 80	5.0 ~ 8.0
Front axle pinch bolt		15 ~ 25	1.5 ~ 2.5
Front fork damper rod bolt		20 ~ 30	2.0 ~ 3.0
Front fork upper clamp bolt		22 ~ 35	2.2 ~ 3.5
Front fork cap bolt		20 ~ 30	2.0 ~ 3.0
Front fork lower clamp bolt		22 ~ 35	2.2 ~ 3.5
Footrest mounting bolt		40 ~ 60	4.0 ~ 6.0
Frame down tube mounting bolt		22 ~ 35	2.2 ~ 3.5
Handlebar clamp bolt		18 ~ 28	1.8 ~ 2.8
Handlebar holder nut		40 ~ 60	4.0 ~ 6.0

⊙ EI SYSTEM PARTS

ITEM	N · m	kgf · m
Water temperature sensor (WT sensor)	5 ~ 8	0.5 ~ 0.8
Fuel injector bolt	5 ~ 8	0.5 ~ 0.8
Intake air temperature sensor (IAT sensor)	5 ~ 8	0.5 ~ 0.8

SERVICE DATA

⊙ VALVE + GUIDE

Unit : mm (in)

ITEM	STANDARD		LIMIT
Valve diam.	IN.	31.0 (1.22)	—
	EX.	25.5 (1.00)	—
Valve clearance (When cold)	IN.	0.1 ~ 0.2 (0.004 ~ 0.008)	—
	EX.	0.28 ~ 0.32 (0.011 ~ 0.013)	—
Valve guide to valve stem clearance	IN.	0.020 ~ 0.047 (0.0008 ~ 0.0019)	—
	EX.	0.030 ~ 0.057 (0.0012 ~ 0.0022)	—
Valve stem deflection	IN. & EX.	—	0.35 (0.014)
Valve guide I.D.	IN. & EX.	4.500 ~ 4.512 (0.1771 ~ 0.1776)	—
Valve stem O.D.	IN.	4.465 ~ 4.480 (0.1758 ~ 0.1764)	—
	EX.	4.455 ~ 4.470 (0.1754 ~ 0.1760)	—
Valve stem runout	IN. & EX.	—	0.05 (0.002)
Valve head thickness	IN. & EX.	—	0.50 (0.02)
Valve seat width	1.2 ~ 1.7 (0.047 ~ 0.067)		—
Valve seat angle	IN. & EX.	45°	—
Valve head radial runout	IN. & EX.	—	0.03 (0.0012)
Valve spring free length	Inner	—	36.8 (1.45)
	Outer	—	39.8 (1.57)
Valve spring tension	Inner.	4.2 ~ 4.8 kgf (9.3 ~ 10.6 lbs) at length 29.9 mm (1.18 in)	—
	Outer	17.0 ~ 19.6 kgf (37.5 ~ 43.2 lbs) at length 33.4 mm (1.32 in)	—

9-21 SERVICING INFORMATION

⊙ **CYLINDER + PISTON + PISTON RING**

Unit : mm (in)

ITEM	STANDARD		LIMIT
Compression pressure	14 kgf/cm ² (at 500 rpm)		12 kgf/cm ²
Piston to cylinder clearance	0.045 ~ 0.075 (0.0018 ~ 0.0030)		0.120 (0.0047)
Cylinder bore	81.500 ~ 81.515 (3.2087 ~ 3.2093)		81.575 (3.2116)
Piston diam.	81.440 ~ 81.455 (3.2063 ~ 3.2069) [Measure at 20 mm (0.79 in) from the skirt end]		81.380 (3.2039)
Cylinder or cylinder head distortion	—		0.05 (0.002)
Piston ring free end gap	1st	Approx 9.9 (0.390)	7.9 (0.311)
	2nd	Approx 10.5 (0.413)	8.4 (0.330)
Piston ring end gap (Assembly condition)	1st	0.20 ~ 0.35 (0.008 ~ 0.013)	0.5 (0.020)
	2nd	0.20 ~ 0.35 (0.008 ~ 0.013)	0.7 (0.028)
Piston ring to groove clearance	1st	—	0.180 (0.007)
	2nd	—	0.150 (0.006)
Piston ring groove width	1st	1.21 ~ 1.23 (0.0476 ~ 0.0484)	—
	2nd	1.01 ~ 1.03 (0.040 ~ 0.041)	—
	Oil	2.01 ~ 2.03 (0.079 ~ 0.080)	—
Piston ring thickness	1st	0.970 ~ 0.990 (0.0382 ~ 0.0390)	—
	2nd	1.170 ~ 1.190 (0.0461 ~ 0.0469)	—
Piston pin hole bore	20.002 ~ 20.008 (0.7875 ~ 0.7877)		20.030 (0.7886)
Piston pin O.D.	19.996 ~ 20.000 (0.7872 ~ 0.7874)		19.980 (0.7866)

⊙ OIL PUMP

ITEM	STANDARD	NOTE
Oil pressure	2.0 ~ 6.0 kgf/cm ² (at 60 °C, 3,000 rpm)	—
Oil pump reduction ratio	1.3 (45/34)	—

⊙ CLUTCH

Unit : mm (in)

ITEM	STANDARD	LIMIT
Clutch cable play	2 (0.08)	—
Drive plate thickness	NO. 1 2.92 ~ 3.08 (0.115 ~ 0.121)	2.62 (0.103)
	NO. 2 3.42 ~ 3.58 (0.135 ~ 0.141)	3.12 (0.123)
Drive plate claw width	NO. 1 15.9 ~ 16.0 (0.626 ~ 0.630)	15.1 (0.595)
	NO. 2 15.9 ~ 16.0 (0.626 ~ 0.630)	15.1 (0.595)
Driven plate distortion	—	0.1 (0.004)
Clutch spring free length	54.2 (2.134)	51 (2.008)

⊙ CAMSHAFT + CYLINDER HEAD

Unit : mm (in)

ITEM	STANDARD	LIMIT
Cam height	IN. 35.28 ~ 35.32 (1.389 ~ 1.391)	34.98 (1.377)
	EX. 33.38 ~ 33.42 (1.314 ~ 1.316)	33.08 (1.302)
Camshaft journal holder I.D.	IN. & EX. 21.959 ~ 21.980 (0.8645 ~ 0.8654)	—
Camshaft journal oil clearance	IN. & EX. —	0.15 (0.006)
Cylinder and cylinder head distortion	—	0.05 (0.002)
Cylinder head cover distortion	—	0.05 (0.002)
Cam chain pin (Arrow "3")	16th pin	—

⊙ CONROD + CRANKSHAFT

Unit : mm (in)

ITEM	STANDARD	LIMIT
Conrod small end I.D.	20.006 ~ 20.014 (0.7876 ~ 0.7880)	20.040 (0.7890)
Conrod deflection	—	3.0 (0.12)
Conrod big end side clearance	0.17 ~ 0.32 (0.007 ~ 0.013)	0.50 (0.020)
Conrod big end width	20.95 ~ 21.00 (0.825 ~ 0.827)	—
Crank web to web width	96.9 ~ 97.1 (3.815 ~ 3.823)	—
Crankshaft runout	—	0.05 (0.002)

9-23 SERVICING INFORMATION

⊙ TRANSMISSION + DRIVE BELT

Unit : mm (in)

ITEM		STANDARD		LIMIT
Primary reduction ratio		2.09 (71/34)		—
Secondary reduction ratio		2.69 (78/29)		—
Gear ratio	1st	2.46 (32/13)		—
	2nd	1.78 (32/18)		—
	3rd	1.38 (29/21)		—
	4th	1.13 (27/24)		—
	5th	0.96 (25/26)		—
Shift fork to groove clearance		0.10 ~ 0.30 (0.004 ~ 0.012)		0.50 (0.020)
Shift fork groove width	NO.1 & NO.2	4.85 ~ 5.00 (0.191 ~ 0.197)		—
	NO.3	4.85 ~ 5.00 (0.191 ~ 0.197)		—
Shift fork thickness	NO.1 & NO.2	5.3 ~ 5.4 (0.209 ~ 0.213)		—
	NO.3	5.3 ~ 5.4 (0.209 ~ 0.213)		—
Drive belt	Type	Poly chain belt		—
	Width	26 (1.02)		—
	Pitch	11 (0.43)		—
Drive belt slack (4.5kgf of Force)	When the rear tire is touched the ground	4.5 ~ 5.5 (0.18 ~ 0.22)		—
	When the rear tire is not touched the ground	5.0 ~ 6.0 (0.20 ~ 0.24)		—
Bend capacity of drive belt	Inner	least 102 (4.02)		—
	Back	least 204 (8.04)		—

⊙ EI SENSORS

ITEM	SPECIFICATION		NOTE
IAP sensor input voltage	4.5 ~ 5.5 V		
IAP sensor output voltage	Approx. 2.7 V at idle speed		
TP sensor input voltage	4.9 ~ 5.1 V		
TP sensor output voltage	Closed	Approx. 1.07 ~ 1.17 V	
	Opened	Approx. 4.30 ~ 4.70 V	
IAT sensor resistance	0.081 ~ 48.352 k Ω [When Intake air temperature is -40°C ~ 130°C (-40°F ~ 266°F)]		
IAT sensor resistance (each temperature)	Refer to page 4-32		
Purge control valve resistance	19 ~ 22 Ω [at 20°C (68°F)]		

⊙ THROTTLE BODY

ITEM	SPECIFICATION	NOTE
Bore size	\varnothing 39	
Idle rpm	1,400 ~ 1,600 rpm	
Throttle cable play	0.5 ~ 1.0 mm (0.02 ~ 0.04 in)	

⊙ FUEL INJECTOR + FUEL PUMP

ITEM	SPECIFICATION	NOTE
Fuel injector resistance	11.4 ~ 12.6 Ω at 20°C (68°F)	
Fuel injector voltage	Battery voltage	
Fuel pressure of fuel pump	Approx. 2.25 ~ 2.50 kgf/cm ² (220 ~ 245 kPa, 32.0 ~ 35.6 psi)	

⊙ THERMOSTAT + COOLING FAN + COOLANT

ITEM	STANDARD		NOTE
Thermostat valve operating temperature	Valve opening	88 °C (190 °F)	
	Valve full open	100 °C (212 °F)	
	Valve closing	83 °C (181 °F)	
Thermostat valve lift	Over 8 mm (0.32 in) / 100 °C (212 °F)		
WT sensor resistance	0.1163 ~ 48.1400 KΩ [When Water temperature is -40 °C ~ 120 °C (-40 °F ~ 248 °F)]		
WT sensor resistance [To ECU] (each temperature)	-40 °C (-40 °F)	Approx. 48.140 KΩ	
	0 °C (32 °F)	Approx. 5.790 KΩ	
	20 °C (68 °F)	Approx. 2.450 KΩ	
	40 °C (104 °F)	Approx. 1.148 KΩ	
	60 °C (140 °F)	Approx. 0.586 KΩ	
	80 °C (176 °F)	Approx. 0.322 KΩ	
	120 °C (248 °F)	Approx. 0.1163 KΩ	
Cooling fan thermo-switch operating temperature	OFF→ON	Approx. 95 °C (203 °F)	
	ON→OFF	Approx. 88 °C (190 °F)	
Engine coolant type	Use an antifreeze/coolant compatible with aluminum radiator, mixed with distilled water only, at the ratio of 50 : 50		
Engine coolant capacity	Reserve tank side	230 ml	
	Radiator side	430 ml	
	Engine side	940 ml	

⊙ **ELECTRICAL**

Unit : mm (in)

ITEM	STANDARD		NOTE
Ignition timing	BTDC 5° / 1,600 rpm and BTDC 35° / 7,000rpm		
Spark plug	Type	CR8E	
	Gap	0.7 ~ 0.8 (0.028 ~ 0.032)	
	Hot type	CR7E	
	Standard type	CR8E	
	Cold type	CR9E	
Spark performance	Over 8 mm (0.32 in)		
Ignition coil primary peak voltage	400 V and more		
Ignition coil resistance	Primary	0.52 ~ 0.64 Ω	
	Secondary	6.4 ~ 7.8 KΩ	
Stator coil resistance	Pick-up coil	110 ~ 140 Ω	G-L
	Charging coil	0.2 ~ 0.4 Ω	Y-Y
Magneto no-load voltage	Over 70 V / 5,000 rpm		
Battery standard charging voltage	13.5 ~ 15.0 V / 5,000 rpm		
Battery	Type	STX14-BS	
	Capacity	12V 12Ah	
	Standard electrolyte S.G.	1.320 at 20°C (68°F)	
Fuse size	Main	30A	
	ECU	15A	

⊙ **WATTAGE**

Unit : W

ITEM	SPECIFICATION
Head lamp	12V - H4 : 60 / 55 W × 1
Position lamp	12V - W5 W × 1
License plate lamp	12V - W5 W × 1
Brake / Tail lamp	LED type
Turn signal lamp	12V - RY10 W × 4
"FI" Check lamp	LED type
Neutral Indicator lamp	LED type
Turn signal indicator lamp (Right & left)	LED type
High beam indicator lamp	LED type
Meter lamp	LED type
Fuel meter & Odometer / Trip meter & Clock	LCD type

※ LED : Light Emitting Diode

LCD : Liquid Crystal Display

 **CAUTION**

Do not use except the specified bulb (Wattage).

9-27 SERVICING INFORMATION

⊙ SUSPENSION

Unit : mm (in)

ITEM	STANDARD	LIMIT
Front fork stroke	130 (5.12)	——
Front fork spring free length	338 (13.3)	321 (12.6)
Front fork oil type	TELLUS #32	——
Front fork oil level	136 mm (5.4 in) from end of outer tube (when maximum compressed without spring)	——
Front fork oil capacity (each leg)	370 ± 4 cc	——
Rear wheel travel	90 (3.54)	——
Swingarm pivot shaft runout	——	0.6 (0.024)
Rear shock absorber pre-load position	2 / 5 position	——
Rear shock absorber spring length	210.5 (8.29)	200.0 (7.87)

⊙ BRAKE + WHEEL

Unit : mm (in)

ITEM		STANDARD	LIMIT
Brake disk thickness	Front	4.0 (0.16)	3.0 (0.12)
	Rear	4.3 (0.17)	3.0 (0.12)
Brake disk runout	Front · Rear	—	0.3 (0.012)
Master cylinder bore	Front	14.280 ~ 14.320 (0.5622 - 0.5638)	—
	Rear	12.700 ~ 12.743 (0.5000 ~ 0.5017)	—
Master cylinder piston diam.	Front	14.230 ~ 14.260 (0.5602 ~ 0.5614)	—
	Rear	12.657 ~ 12.684 (0.4983 ~ 0.4994)	—
Brake caliper cylinder bore	Front	30.2 (1.19)	—
	Rear	25.4 (1.00)	—
Brake caliper piston diam.	Front	30.2 (1.19)	—
	Rear	25.4 (1.00)	—
Brake fluid type	Front	DOT4	—
	Rear	DOT4	—
Wheel runout	Axial	—	2.0 (0.08)
	Radial	—	2.0 (0.08)
Wheel axle runout	Front	—	0.25 (0.01)
	Rear	—	0.25 (0.01)
Tire size	Front	120/80 - 16 60H	—
	Rear	170/80 - 15 77H	—
Wheel rim size	Front	J16 × MT2.75	—
	Rear	J15 × MT4.00	—

⊙ TIRE PRESSURE

COLD INFLATION TIRE PRESSURE	NORMAL RIDING					
	SOLO RIDING			DUAL RIDING		
	kPa	kgf/cm ²	psi	kPa	kgf/cm ²	psi
FRONT	200	2.00	30.0	225	2.25	33.0
REAR	225	2.25	33.0	250	2.50	36.0

⊙ FUEL + OIL

ITEM	SPECIFICATION		NOTE
Fuel type	Gasoline used should be graded 91 octane or higher. An unleaded gasoline is recommended.		
Fuel tank capacity	17 ℓ		
Engine oil type	API Over SL (SAE 10W/40)		
Engine oil capacity	Change	3,000 ml	
	Filter change	3,200 ml	
	Overhaul	3,400 ml	

WIRE AND CABLE ROUTING

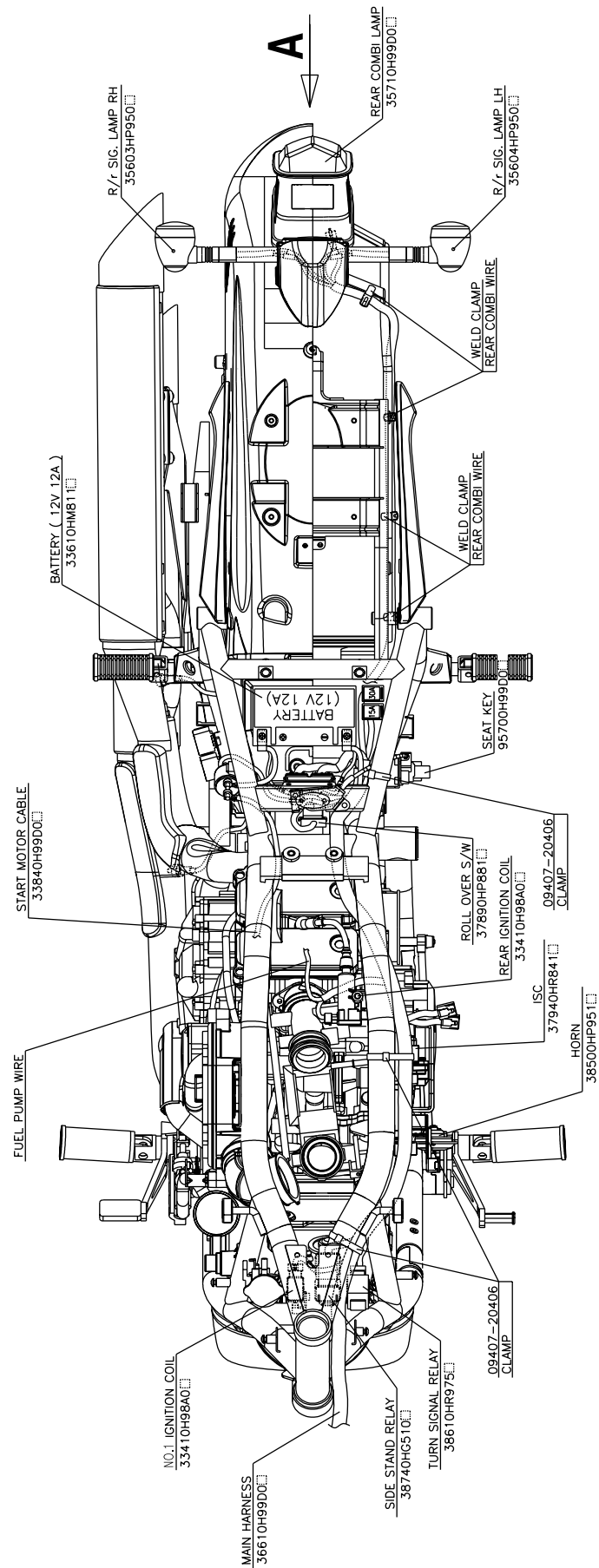

9-31 SERVICING INFORMATION

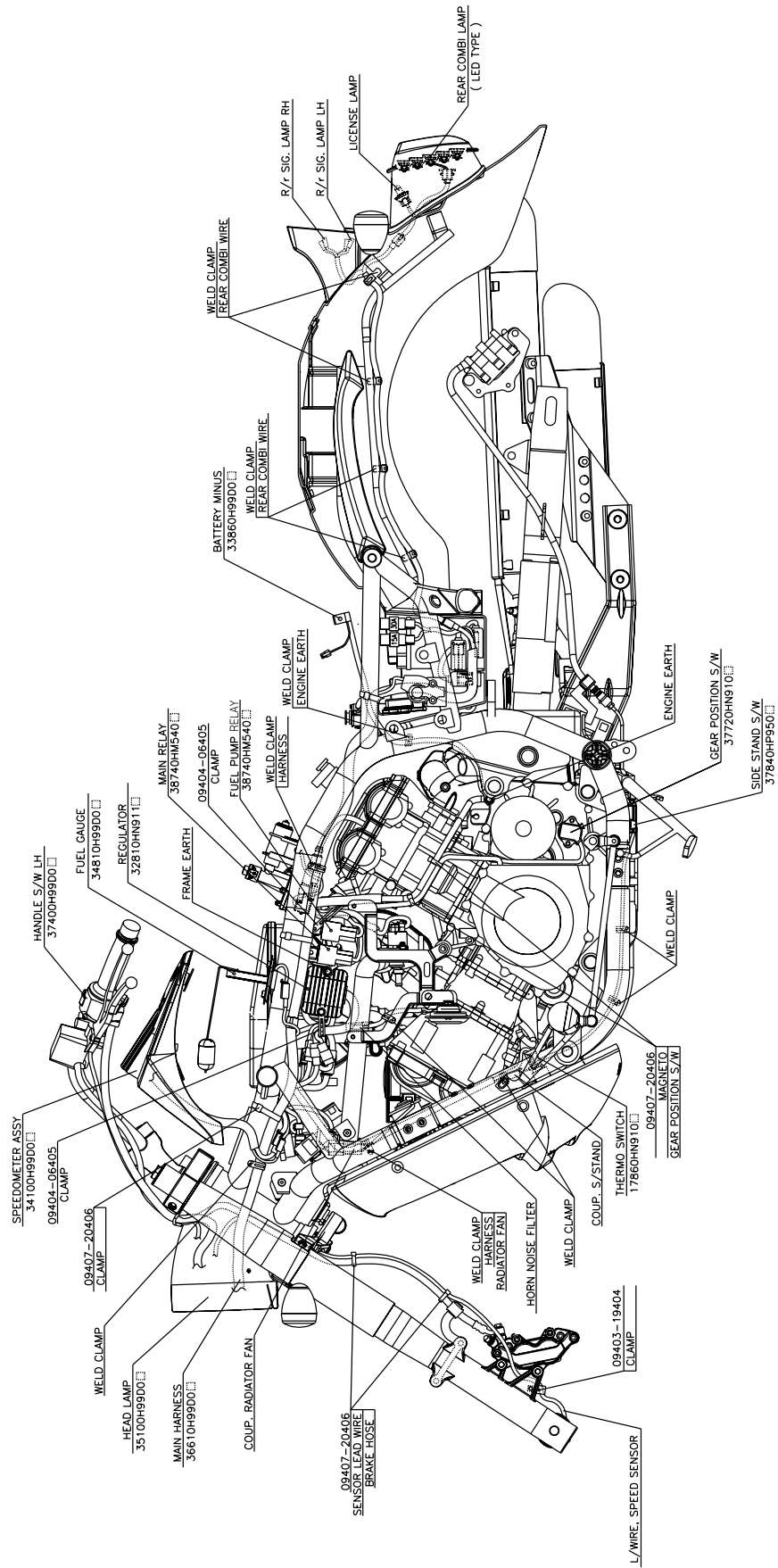

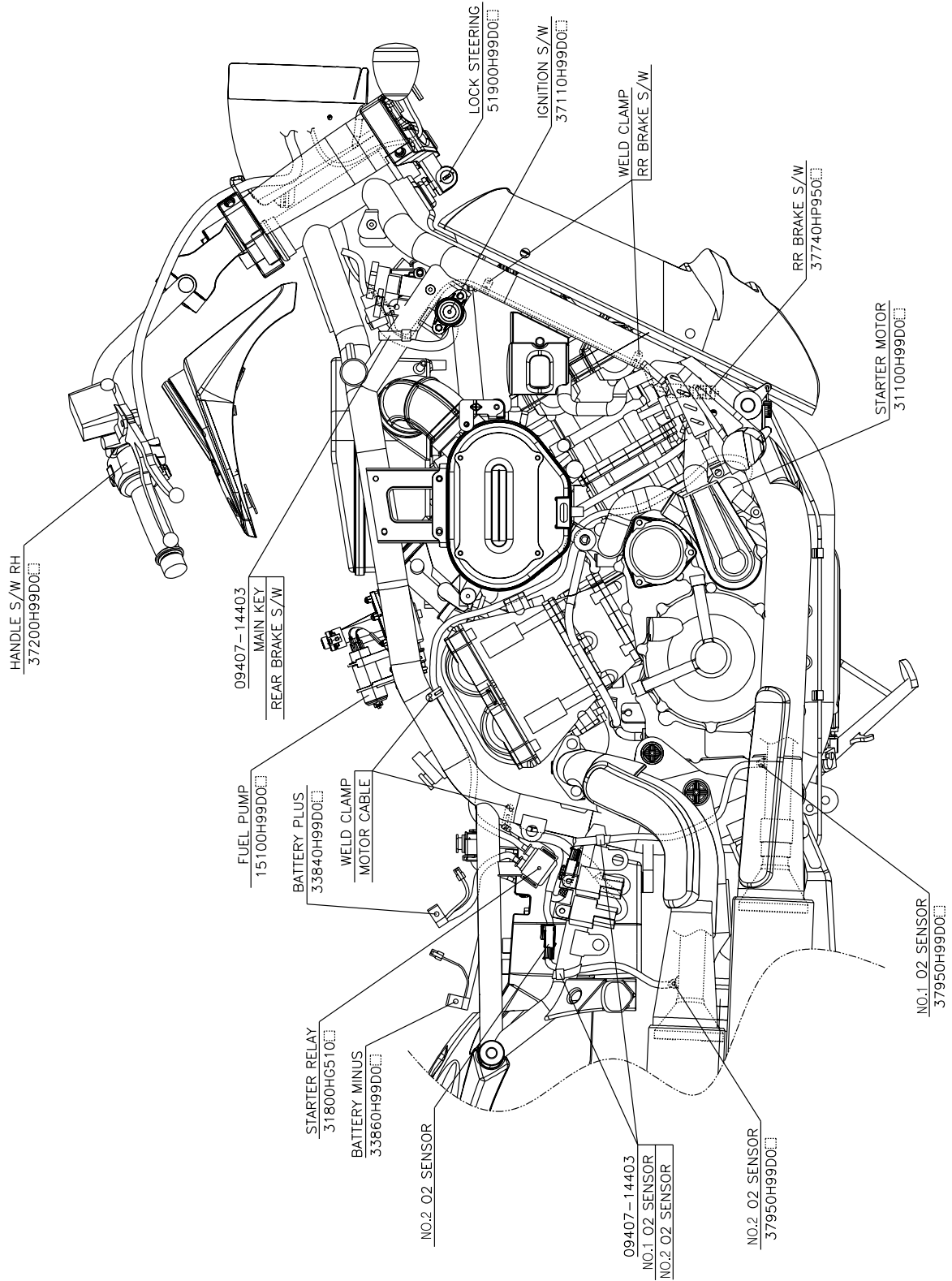

9-33 SERVICING INFORMATION

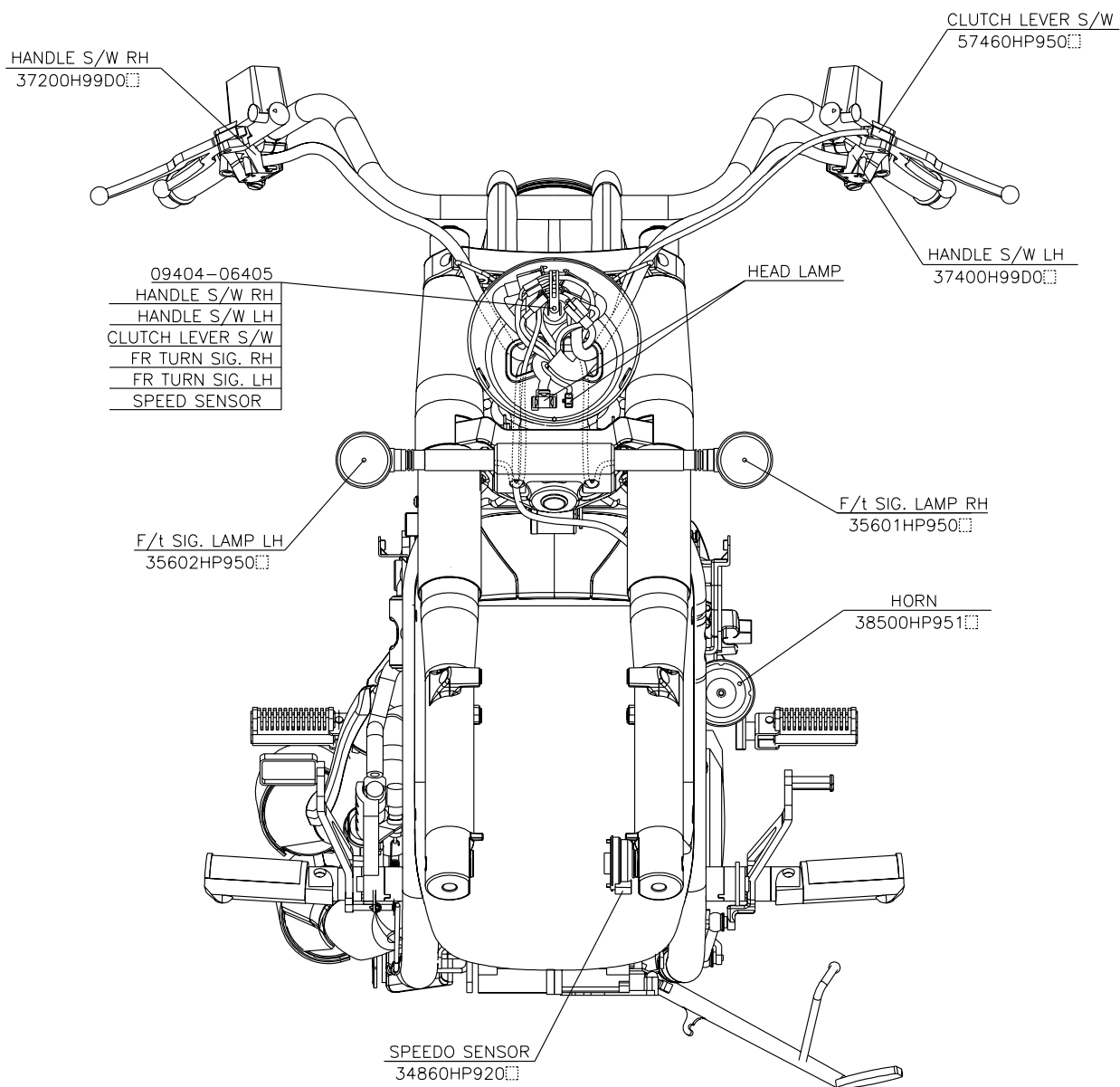

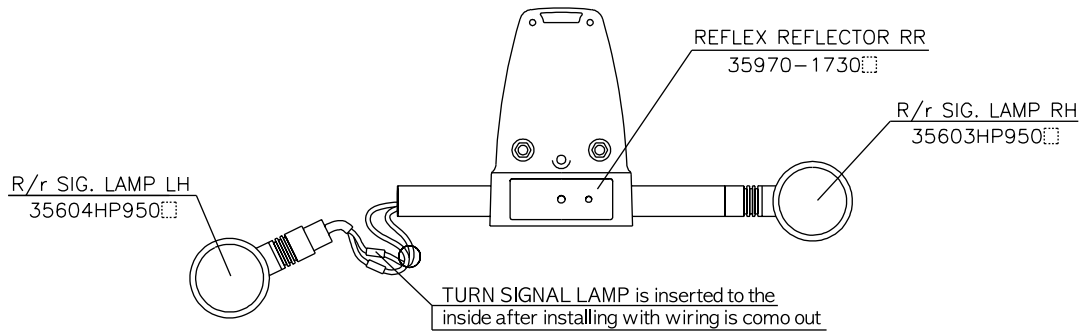

VIEW A

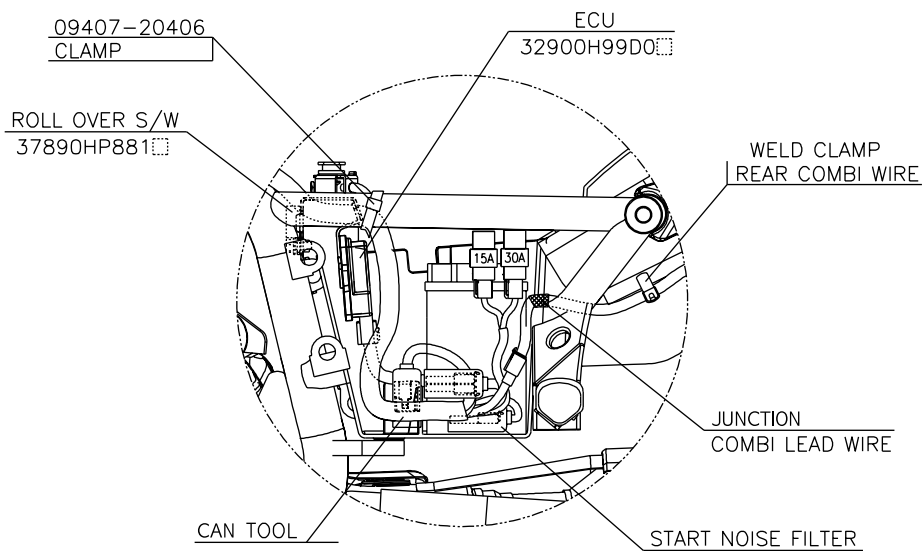

ECU VIEW

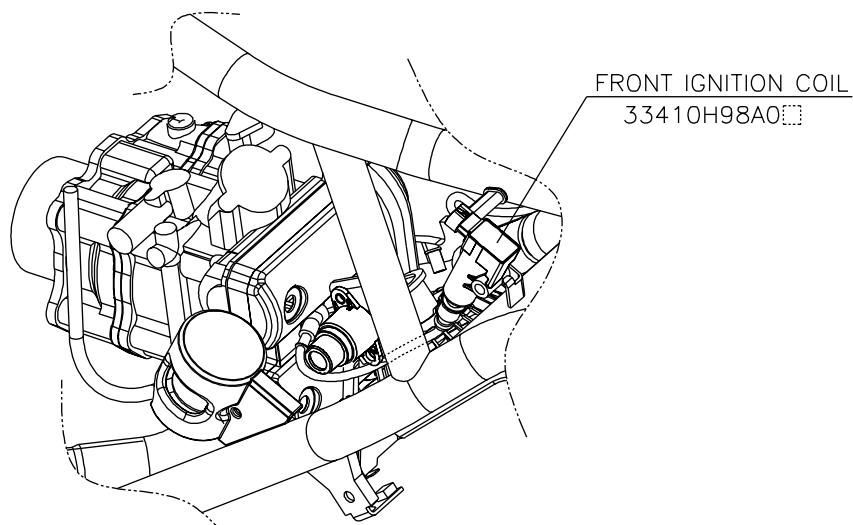

FRONT IGNITION COIL VIEW

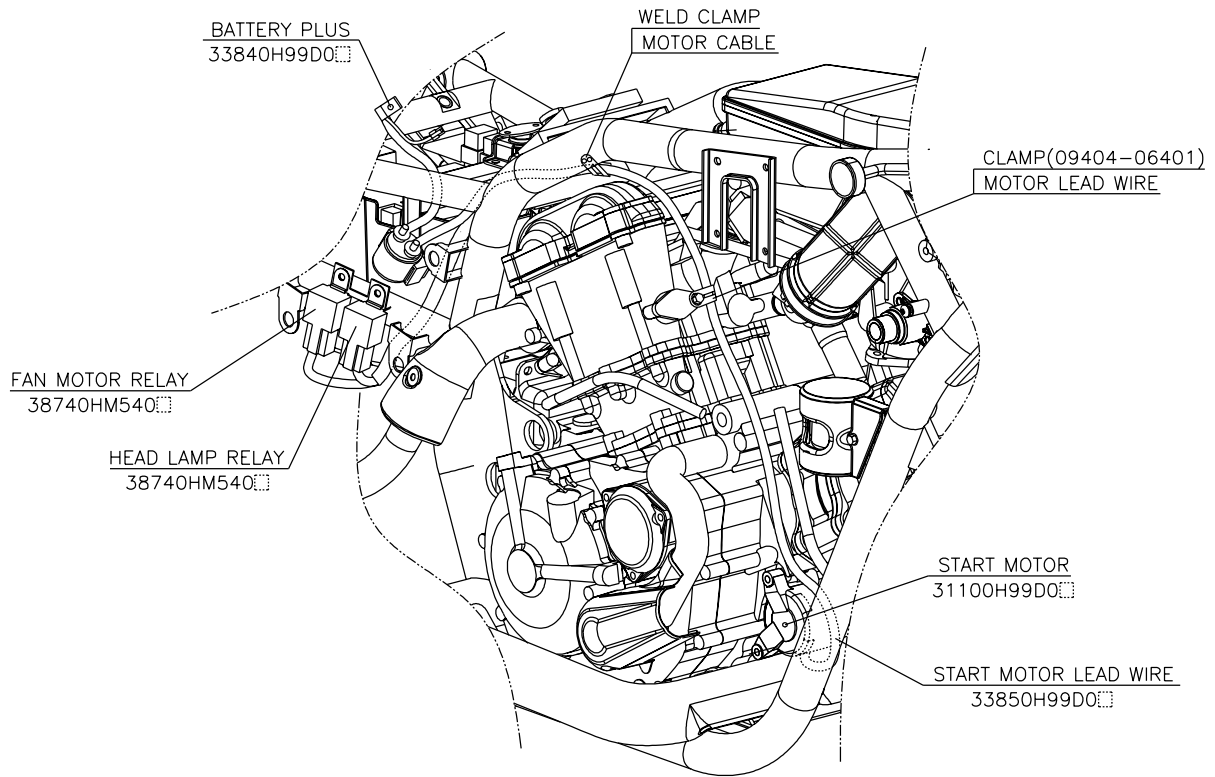

START MOTOR CABLE VIEW

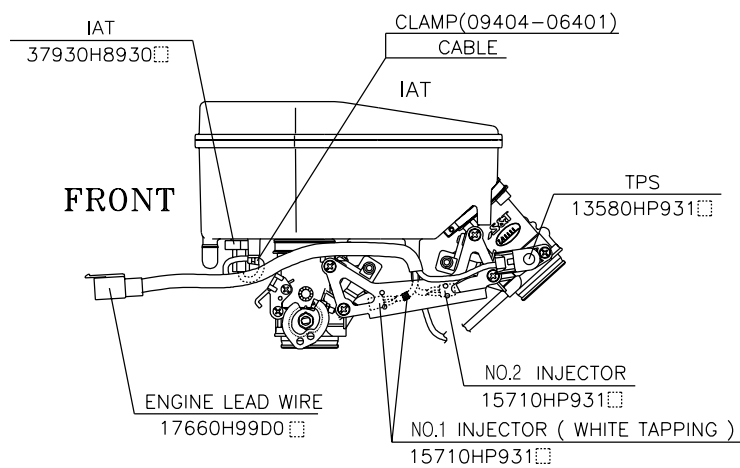

AIR CLEANER VIEW

WIRING DIAGRAM

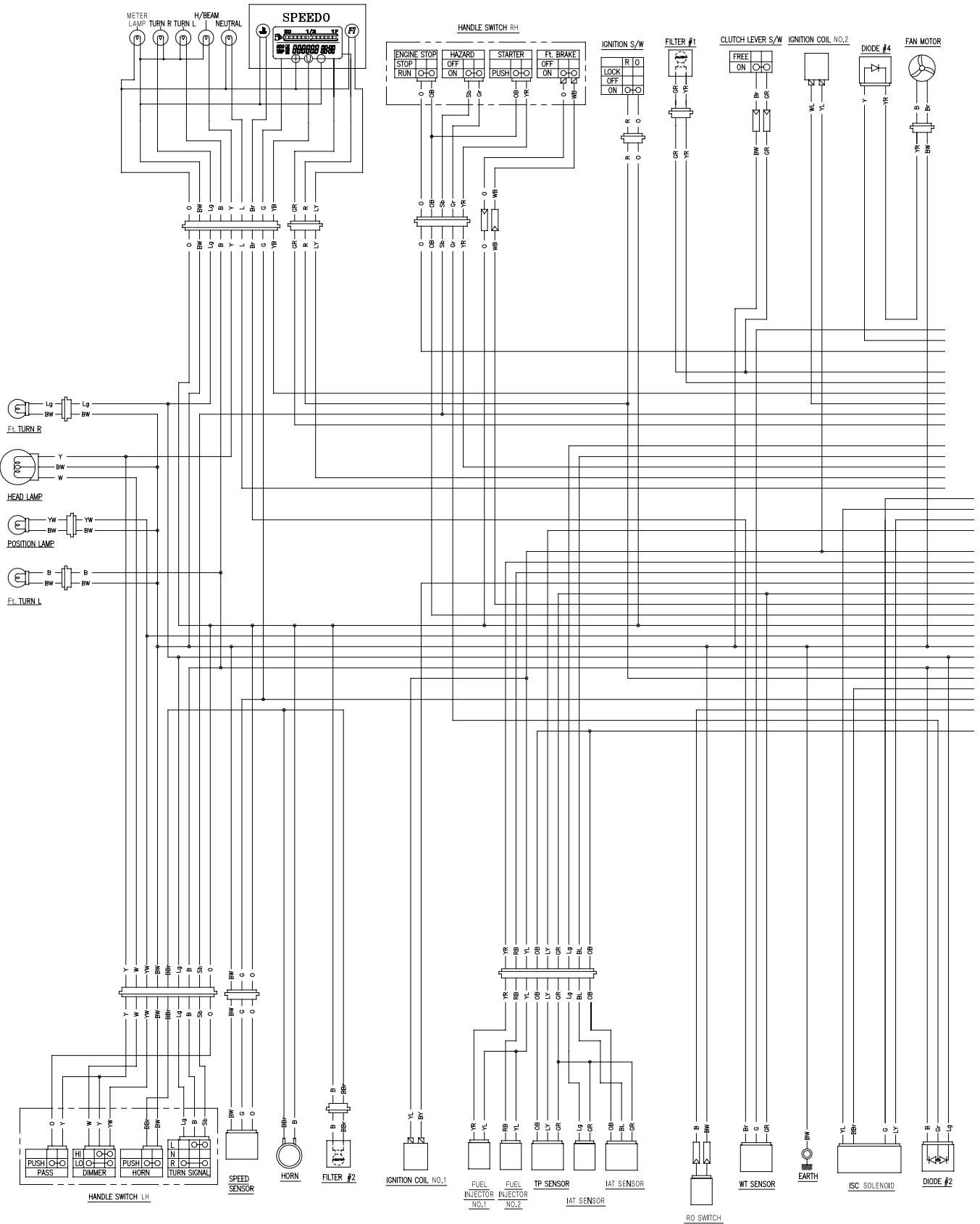

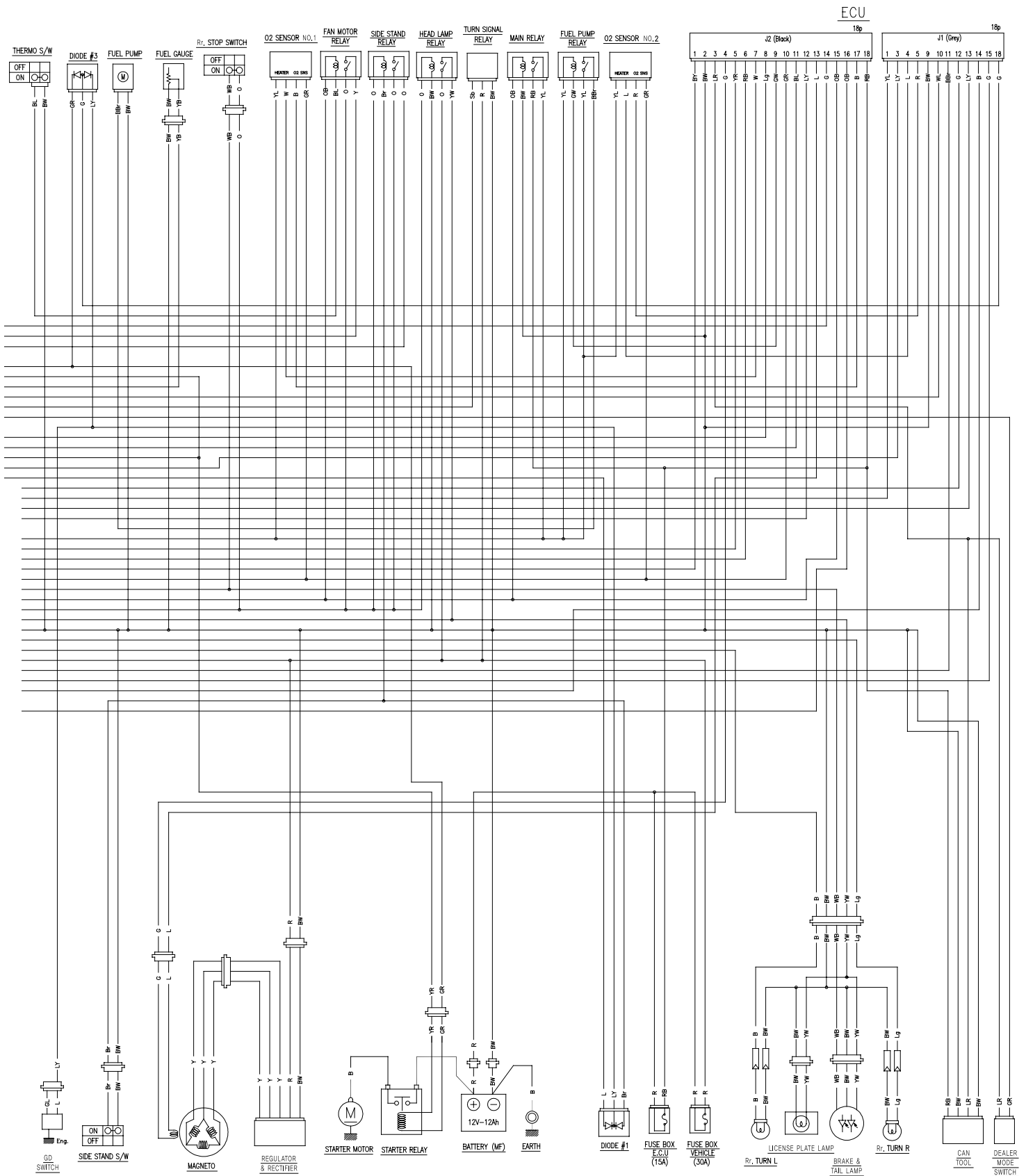

TAPPET SHIM SELECTION CHART (IN.)

SHIM No.	Specified clearance - Adjustment unnecessary																				
	120	125	130	135	140	145	150	155	160	165	170	175	180	185	190	195	200	205	210	215	220
MEASURING TAPPET CLEARANCE (mm)	1.20	1.25	1.30	1.35	1.40	1.45	1.50	1.55	1.60	1.65	1.70	1.75	1.80	1.85	1.90	1.95	2.00	2.05	2.10	2.15	2.20
SHIM THICKNESS AT PRESENT (mm)	1.20	1.25	1.30	1.35	1.40	1.45	1.50	1.55	1.60	1.65	1.70	1.75	1.80	1.85	1.90	1.95	2.00	2.05	2.10	2.15	2.20
0.00 ~ 0.04			1.20	1.25	1.30	1.35	1.40	1.45	1.50	1.55	1.60	1.65	1.70	1.75	1.80	1.85	1.90	1.95	2.00	2.05	2.10
0.05 ~ 0.09		1.20	1.25	1.30	1.35	1.40	1.45	1.50	1.55	1.60	1.65	1.70	1.75	1.80	1.85	1.90	1.95	2.00	2.05	2.10	2.15
0.10 ~ 0.20																					
0.21 ~ 0.25	1.30	1.35	1.40	1.45	1.50	1.55	1.60	1.65	1.70	1.75	1.80	1.85	1.90	1.95	2.00	2.05	2.10	2.15	2.20		
0.26 ~ 0.30	1.35	1.40	1.45	1.50	1.55	1.60	1.65	1.70	1.75	1.80	1.85	1.90	1.95	2.00	2.05	2.10	2.15	2.20			
0.31 ~ 0.35	1.40	1.45	1.50	1.55	1.60	1.65	1.70	1.75	1.80	1.85	1.90	1.95	2.00	2.05	2.10	2.15	2.20				
0.36 ~ 0.40	1.45	1.50	1.55	1.60	1.65	1.70	1.75	1.80	1.85	1.90	1.95	2.00	2.05	2.10	2.15	2.20					
0.41 ~ 0.45	1.50	1.55	1.60	1.65	1.70	1.75	1.80	1.85	1.90	1.95	2.00	2.05	2.10	2.15	2.20						
0.46 ~ 0.50	1.55	1.60	1.65	1.70	1.75	1.80	1.85	1.90	1.95	2.00	2.05	2.10	2.15	2.20							
0.51 ~ 0.55	1.60	1.65	1.70	1.75	1.80	1.85	1.90	1.95	2.00	2.05	2.10	2.15	2.20								
0.56 ~ 0.60	1.65	1.70	1.75	1.80	1.85	1.90	1.95	2.00	2.05	2.10	2.15	2.20									
0.61 ~ 0.65	1.70	1.75	1.80	1.85	1.90	1.95	2.00	2.05	2.10	2.15	2.20										
0.66 ~ 0.70	1.75	1.80	1.85	1.90	1.95	2.00	2.05	2.10	2.15	2.20											
0.71 ~ 0.75	1.80	1.85	1.90	1.95	2.00	2.05	2.10	2.15	2.20												
0.76 ~ 0.80	1.85	1.90	1.95	2.00	2.05	2.10	2.15	2.20													
0.81 ~ 0.85	1.90	1.95	2.00	2.05	2.10	2.15	2.20														
0.86 ~ 0.90	1.95	2.00	2.05	2.10	2.15	2.20															
0.91 ~ 0.95	2.00	2.05	2.10	2.15	2.20																
0.96 ~ 1.00	2.05	2.10	2.15	2.20																	
1.01 ~ 1.05	2.10	2.15	2.20																		
1.06 ~ 1.10	2.15	2.20																			
1.11 ~ 1.15	2.20																				

HOW TO USE THE CHART

1. Measure the tappet clearance. (When cold)
2. Measure the shim thickness at present.
3. Look for meeting space in that horizontal line for thickness and vertical line for clearance.

(EXAMPLE)

When the tappet clearance is 0.23 mm and the shim thickness at present is 1.70 mm, the shim thickness should be used 1.80 mm.



TAPPET SHIM SELECTION CHART (EX.)

MEASURING TAPPET CLEARANCE (mm)	SHIM No.		120	125	130	135	140	145	150	155	160	165	170	175	180	185	190	195	200	205	210	215	220	
	SHIM THICKNESS AT PRESENT (mm)		1.20	1.25	1.30	1.35	1.40	1.45	1.50	1.55	1.60	1.65	1.70	1.75	1.80	1.85	1.90	1.95	2.00	2.05	2.10	2.15	2.20	
0.13 ~ 0.17						1.20	1.25	1.30	1.35	1.40	1.45	1.50	1.55	1.60	1.65	1.70	1.75	1.80	1.85	1.90	1.95	2.00	2.05	
0.18 ~ 0.22				1.20	1.25	1.30	1.35	1.40	1.45	1.50	1.55	1.60	1.65	1.70	1.75	1.80	1.85	1.90	1.95	2.00	2.05	2.10	2.15	
0.23 ~ 0.27			1.20	1.25	1.30	1.35	1.40	1.45	1.50	1.55	1.60	1.65	1.70	1.75	1.80	1.85	1.90	1.95	2.00	2.05	2.10	2.15	2.20	
0.28 ~ 0.32																								
Specified clearance - Adjustment unnecessary																								
0.33 ~ 0.37			1.25	1.30	1.35	1.40	1.45	1.50	1.55	1.60	1.65	1.70	1.75	1.80	1.85	1.90	1.95	2.00	2.05	2.10	2.15	2.20		
0.38 ~ 0.42			1.30	1.35	1.40	1.45	1.50	1.55	1.60	1.65	1.70	1.75	1.80	1.85	1.90	1.95	2.00	2.05	2.10	2.15				
0.43 ~ 0.47			1.35	1.40	1.45	1.50	1.55	1.60	1.65	1.70	1.75	1.80	1.85	1.90	1.95	2.00	2.05	2.10	2.15					
0.48 ~ 0.52			1.40	1.45	1.50	1.55	1.60	1.65	1.70	1.75	1.80	1.85	1.90	1.95	2.00	2.05	2.10	2.15						
0.53 ~ 0.57			1.45	1.50	1.55	1.60	1.65	1.70	1.75	1.80	1.85	1.90	1.95	2.00	2.05	2.10	2.15							
0.58 ~ 0.62			1.50	1.55	1.60	1.65	1.70	1.75	1.80	1.85	1.90	1.95	2.00	2.05	2.10	2.15								
0.63 ~ 0.67			1.55	1.60	1.65	1.70	1.75	1.80	1.85	1.90	1.95	2.00	2.05	2.10	2.15									
0.68 ~ 0.72			1.60	1.65	1.70	1.75	1.80	1.85	1.90	1.95	2.00	2.05	2.10	2.15										
0.73 ~ 0.77			1.65	1.70	1.75	1.80	1.85	1.90	1.95	2.00	2.05	2.10	2.15											
0.78 ~ 0.82			1.70	1.75	1.80	1.85	1.90	1.95	2.00	2.05	2.10	2.15												
0.83 ~ 0.87			1.75	1.80	1.85	1.90	1.95	2.00	2.05	2.10	2.15													
0.88 ~ 0.92			1.80	1.85	1.90	1.95	2.00	2.05	2.10	2.15														
0.93 ~ 0.97			1.85	1.90	1.95	2.00	2.05	2.10	2.15															
0.98 ~ 1.02			1.90	1.95	2.00	2.05	2.10	2.15																
1.03 ~ 1.07			1.95	2.00	2.05	2.10	2.15																	
1.08 ~ 1.12			2.00	2.05	2.10	2.15																		
1.13 ~ 1.17			2.05	2.10	2.15																			
1.18 ~ 1.22			2.10	2.15																				
1.23 ~ 1.27			2.15																					

HOW TO USE THE CHART

1. Measure the tappet clearance. (When cold)
2. Measure the shim thickness at present.
3. Look for meeting space in that horizontal line for thickness and vertical line for clearance.

(EXAMPLE)

When the tappet clearance is 0.35 mm and the shim thickness at present is 1.70 mm, the shim thickness should be used 1.75 mm.



Prepared by

 **HYOSUNG**
S&T Motors Co., Ltd.

1st Ed. JAN. 2010.

Manual No. 99000H99D10

Printed in Korea

S&T Motors Co., Ltd.